

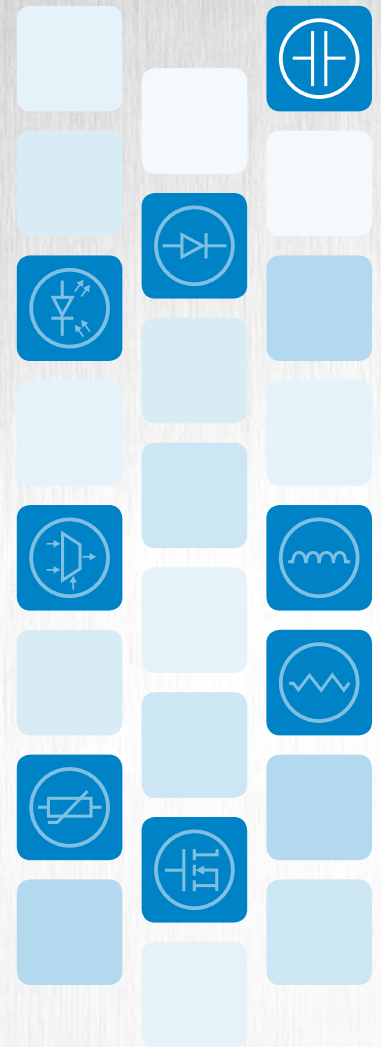

ESTAspring POWER CAPACITORS LOW VOLTAGE - Vishay ESTA



World's First Terminal Block
With Lever-Operated Spring Connection



ABOUT VISHAY INTERTECHNOLOGY, INC.

GLOBAL INDUSTRY LEADER

Vishay Intertechnology was founded in 1962 by Dr. Felix Zandman, with a loan from his cousin Alfred P. Slaner. The Company was named after Dr. Zandman's ancestral village in Lithuania, in memory of family members who perished in the Holocaust. The Company's initial product portfolio consisted of foil resistors and foil resistance strain gages. In 1985, having grown from a start-up into the world's leading manufacturer of these products, the Company began a series of strategic acquisitions to become a broad-line manufacturer of electronic components. Today, Vishay Intertechnology is one of the world's largest manufacturers of discrete semiconductors and passive electronic components.

As Vishay Intertechnology grew through innovations and acquisitions, its resistive foil technology products became non-core businesses. In 2010, Vishay Intertechnology spun off these non-core businesses into an independent company listed on the New York Stock Exchange: Vishay Precision Group (NYSE: VPG).

DIVERSE MARKETS

Vishay Intertechnology supports customers in virtually every major market sector. Vishay components are used every day in designs around the world, for applications in industrial, communications, transportation, consumer, medical, and defense products. Vishay has manufacturing plants in the Americas, Asia, Europe, and Israel, as well as sales offices worldwide. Its innovations in technology, successful acquisition strategy, superior product quality, and "one-stop shop" service to customers have made the Company a global industry leader.

SOLUTIONS FOR GROWTH

Vishay is very well positioned to provide components for new macroeconomic growth drivers such as connectivity, mobility, and, sustainability. Through its R&D, engineering, quality programs, and sales initiatives, it generates a steady stream of innovative components to enable designers to create new generations of end products.

In tablets, smartphones, and wearables, Vishay components support power management, wireless connectivity, display interface, and touch screen controls, provide protection from the electrostatic discharge (ESD) that can cause component and system failure, and perform other functions. Vishay components are also found in wireless charging devices, mobile payment systems and other near-field communications systems, servers, network devices, base stations, solid-state drives, telematics systems, and other products and systems in our increasingly interconnected world.

In the area of mobility, to take just one example, Vishay components support a wide range of functions in electric power steering, including electromagnetic interference (EMI) filtering, quiescent current switch-off, three-phase motor switching, current sensing, and voltage division. Vishay components also are used in transmission control units, exhaust systems, start-stop systems, climate controls, braking and safety, lighting, infotainment, proximity and gesture recognition, and more. In hybrid vehicles, Vishay components are used in main inverters, high-voltage bus systems, and energy recuperation. Power capacitors, inductors, and high-power resistors are used to move high-speed trains, buses, intralogistic devices, aircraft, ships, and other carriers in modern infrastructure.

In the area of sustainability, Vishay components are used in the main inverters, power filters, and pitch and system controls of wind turbines. Components in wind turbine systems include high-power semiconductor modules, high-voltage MOSFETs, power ICs, diodes and rectifiers, optical isolators, shunt resistors, crowbar resistors, inductors, and power capacitors. Vishay components are used in solar panels and inverters, and for on-panel power conversion. They are used in smart meters and smart grids, power transmission and distribution systems, power grid quality stabilization, oil and gas exploration equipment, energy harvesting, and more.

STRATEGIC ACQUISITIONS	2014	Capella Microsystems Holy Stone Polytech	2000	Cera-Mite Electro-Films Spectrol
	2013	MCB Industrie	1998	Siliconix Telefunken
	2012	HiRel Systems	1994	Vitramon
	2011	Huntington Electric: Resistor businesses	1993	Roederstein
	2008	KEMET: Wet tantalum capacitor business	1992	Sprague
	2007	International Rectifier: PCS business	1988	Sfernice
	2002	BCcomponents Beyschlag	1987	Draloric
	2001	General Semiconductor Infineon: Infrared components business Mallory (NACC) Tansitor	1985	Dale



ESTAspring

Power Capacitors Low Voltage

Vishay ESTA

Vishay Electronic GmbH
ESTA Capacitors Division
Hofmark-Aich-Strasse 36
D-84030 Landshut
Germany
Phone: +49 871 860
Fax: +49 871 862512
www.vishay.com

DISCLAIMER

ALL PRODUCT, PRODUCT SPECIFICATIONS AND DATA ARE SUBJECT TO CHANGE WITHOUT NOTICE TO IMPROVE RELIABILITY, FUNCTION OR DESIGN OR OTHERWISE.

Vishay Intertechnology, Inc., its affiliates, agents, and employees, and all persons acting on its or their behalf (collectively, "Vishay"), disclaim any and all liability for any errors, inaccuracies or incompleteness contained in any datasheet or in any other disclosure relating to any product.

Vishay makes no warranty, representation or guarantee regarding the suitability of the products for any particular purpose or the continuing production of any product. To the maximum extent permitted by applicable law, Vishay disclaims (i) any and all liability arising out of the application or use of any product, (ii) any and all liability, including without limitation special, consequential or incidental damages, and (iii) any and all implied warranties, including warranties of fitness for particular purpose, non-infringement and merchantability.

Statements regarding the suitability of products for certain types of applications are based on Vishay's knowledge of typical requirements that are often placed on Vishay products in generic applications. Such statements are not binding statements about the suitability of products for a particular application. It is the customer's responsibility to validate that a particular product with the properties described in the product specification is suitable for use in a particular application. Parameters provided in datasheets and/or specifications may vary in different applications and performance may vary over time. All operating parameters, including typical parameters, must be validated for each customer application by the customer's technical experts. Product specifications do not expand or otherwise modify Vishay's terms and conditions of purchase, including but not limited to the warranty expressed therein.

Except as expressly indicated in writing, Vishay products are not designed for use in medical, life-saving, or life-sustaining applications or for any other application in which the failure of the Vishay product could result in personal injury or death. Customers using or selling Vishay products not expressly indicated for use in such applications do so at their own risk and agree to fully indemnify and hold Vishay and its distributors harmless from and against any and all claims, liabilities, expenses and damages arising or resulting in connection with such use or sale, including attorneys fees, even if such claim alleges that Vishay or its distributor was negligent regarding the design or manufacture of the part. Please contact authorized Vishay personnel to obtain written terms and conditions regarding products designed for such applications.

No license, express or implied, by estoppel or otherwise, to any intellectual property rights is granted by this document or by any conduct of Vishay. Product names and markings noted herein may be trademarks of their respective owners.



ESTAspring Power Capacitors Low Voltage

GENERAL INFORMATION 2

TERMS AND DEFINITIONS, APPLICABLE STANDARDS

 Definition of ratings..... 4

 Maximum permissible current 4

 Maximum permissible voltage..... 4

 Harmonic distortion 4

 Damping of inrush current..... 4

 Operating temperatures 5

 Degree of protection, IP code 5

PHMKP...-S, PHMKPG...-S, CYLINDRICAL, LVAC, ESTAspring

 Quick reference data 6

 Application..... 7

 Design..... 7

 Technical data 8

 Range of 3-phase types, IP20, oil

 - 230 V, 400 V (415 V) 10

 - 440 V (415 V)..... 11

 - 525 V (480 V)..... 12

 - 660 V (690 V), 690 V (660 V) 13

 Range of 3-phase types, IP20, dry

 - 230 V, 400 V (415 V) 14

 - 440 V (415 V)..... 15

 - 525 V (480 V)..... 16

 - 660 V (690 V), 690 V (660 V) 17

 Range of 1-phase types, IP20, oil

 - 230 V, 400 V (415 V), 525 V (480 V) 18

 Dimensions 19

 Ordering information..... 19

World's First Terminal Block With Lever-Operated Spring Connection



INTRODUCTION

Time is money, and in the control cabinet the wiring of capacitors makes up a considerable part of the assembly time.

Most tubular power capacitors have an IP20 terminal block with a screw connection. Vishay is now introducing a new generation of power capacitors with fast connection technology. Completely screwless, this new technology is significantly faster and simpler through spring force and lever actuation. Due to the lever position, a simple check for the completeness of all connections is possible. The necessary connection force results automatically, free from torque specifications.

In addition, fast connection technology offers maximum contact reliability over the entire service life of the capacitors, and is completely maintenance-free without the need to tighten screws. Particularly in the case of environments with permanent vibrations, such as those experienced in wind power plants, valuable investments remain secure against irreparable damage caused by loose connections.

APPLICATIONS

- Wind power plants
- Solar panels and inverters
- Thermal power stations
- Power factor correction $\leq 1000 \text{ VAC}_{\text{RMS}}$
- Harmonic filters

FEATURES

- Maintenance-free
- Reduced assembly times up to 60 %
- Vibration-proof in wind power plants and during transport
- Optical connection check: lever closed = successfully contacted
- 2.5 mm² up to 25 mm² with wire-end sleeve
- Defined continuous contact force through spring technology
- Stainless steel spring
- Corrosion-proof
- Fast and easy lever-operated wire connection
- Copper alloy for conductor material

STANDARDS FOR ESTAspring TERMINAL BLOCK

- Conductor pull-out test according to IEC 60998-2-1
- Impulse withstand voltage test according to IEC 60664-1
- Current carrying capacity up to 90 A / phase according to IEC 60512-5-2
- Vibration test according to IEC 60068-2-6
- Corrosion test according to IEC 6988
- Temperature shock test according to IEC 60512-11-4, clause 11d
- Degree of protection to IP20, tested according to DIN 40050-9/60529
- UL / ULC



The lever is designed for a minimum of 10 operating cycles. Continuous use can result in excessive wear.



ESTAspring

TYPES AND RATINGS	
Series	PhMKP, oil-filled; PhMKPg, dry, gas-filled
Voltage (VAC) _{RMS}	230 to 1000
Connection	Single = 1; star = 2; delta = 3
Output (kvar)	2 to 37.1/50 Hz; outputs at 60 Hz on request
Terminal / diameter	S = ESTAspring / 64 mm, 84 mm, 116 mm

TYPE DESIGNATION (Example)				
PhMKP	440	.3.	28,10	-S84
Series (oil-filled)	Voltage 440 VAC _{RMS}	Delta-connected	Output 28.1 kvar/50 Hz	ESTAspring on 84 mm diameter can



Low Voltage Power Capacitors

TERMS AND DEFINITIONS, APPLICABLE STANDARDS

ESTAprop and ESTAdry power factor correction capacitors are designed to VDE 0560-46 + 47, IEC 60831-1 + 2 and EN 60831-1 + 2, latest edition.

DEFINITION OF RATINGS

- U_{cn} Rated voltage: The RMS value of the alternating voltage ...
- I_n Rated current: The RMS value of the alternating current ...
- C_n Rated capacitance: The capacitance value ...
... for which the capacitor has been designed.

voltage and rated frequency, excluding transients. Taking into account a previous capacitance tolerance of $1.15 \times C_n$, the maximum current can reach $1.5 \times I_n$.

These overcurrent factors are intended to take into account the combined effects of harmonics, overvoltages and capacitance tolerance.

MAXIMUM PERMISSIBLE VOLTAGE

ESTAprop and ESTAdry MKP-type capacitors are suitable for operation at voltage levels as indicated in the table (extract from IEC 60831-1 clause 20 - table 3) below:

MAXIMUM PERMISSIBLE CURRENT

ESTAprop and ESTAdry MKP-type capacitors are suitable for continuous operation at an RMS line current of 1.3 times the fundamental current that occurs at rated sinusoidal

FREQUENCY RMS	VOLTAGE FACTOR U_{CN}	MAXIMUM DURATION	OBSERVATION
Power frequency	1.0	Continuous	Highest average value during any period of capacitor energization
Power frequency	1.10	8 h in every 24 h	System voltage regulation and fluctuations
Power frequency	1.15	30 min in every 24 h	System voltage regulation and fluctuations
Power frequency	1.20	5 min (only 200 times in the life of the capacitor)	Voltage rise at light load
Power frequency	1.30	1 min (only 200 times in the life of the capacitor)	
Power frequency and Harmonics	Such that the current does not exceed the value given above.		

HARMONIC DISTORTION

Capacitors can be overloaded in networks distorted by harmonics. This situation is even more critical in the case of resonance. Where the capacitor current or voltage can be a few times as high as the nominal voltage. Therefore, special precautions (e.g. series filter circuit reactors) should be taken in networks distorted by harmonics. Our warranty only applies for operating conditions in accordance with the above mentioned standards.

DAMPING OF INRUSH CURRENT

Switching devices especially suited for capacitor switching shall be used. For example, the device shall be such that restriking during breaking operations, which may result in high overvoltages, cannot occur.

The operating experience of ESTAprop MKP-type capacitors since their introduction in 1978 has shown their excellent behavior when being switched.

High output densities and reduction of losses have resulted in reduced resistance of modern MKP-type capacitors. Especially switching capacitors in parallel to others being already energized, cause very high inrush currents which

should be reduced to $\leq 100 \times I_n$ (according to standard). As a consequence, the life cycle of contactors and also capacitors will be affected.

In case of detuned capacitor banks, the inrush current will be limited by the inductivity of the series filter reactors.

For capacitor banks without filter reactors, we recommend the use of capacitor contactors with series resistors.
We recommend these special contactors instead of damping the inrush current by coiling up the connection cable between contactor and capacitor. This is due to superior damping behavior and reduced losses in connecting cables, resulting in temperature reduction inside the cubicle.

Contactors have to be replaced after about 100 000 switching operations.

Modern PFC controllers are able to memorize the switching number per capacitor step.

A regular check of the contactors is strongly recommended.



OPERATING TEMPERATURES

Capacitors are classified for ambient temperature categories, each category being specified by a number followed by a letter. The number represents the lowest ambient-air temperature at which the capacitor may be operated.

The letter represents upper limit of operating temperature, having maximum values specified in the table below.

	AMBIENT TEMPERATURE °C		
	MAXIMUM	MAXIMUM AVERAGE OVER	
		24 h	1 YEAR
A	40	30	20
B	45	35	25
C	50	40	30
D	55	45	35

ESTAprop and ESTAdry, PhMKP-type, cylindrical capacitors are designed for category: -25/D (ESTAprop), -40/D (ESTAdry)

DEGREE OF PROTECTION, IP CODE

Degrees of protection are described by the IP code. The designation consists of the letters "IP" followed by two characteristic figures, e.g. "IP00" means no protection.

The first characteristic figure indicates that:

- the enclosure provides protection of persons against access to hazardous parts by preventing or limiting the ingress of a part of the human body or an object held by a

person; and simultaneously

- the enclosure provides protection of equipment against the ingress of solid foreign objects.

The second characteristic figure indicates the degree of protection provided by enclosures with respect to harmful effects on the equipment due to the ingress of water.

CHARACTERISTIC NUMERICAL	1 ST	2 ND
	PROTECTION AGAINST ACCESS TO HAZARDOUS PARTS AND PENETRATION OF SOLID FOREIGN OBJECTS INCLUDING DUST	PROTECTION AGAINST INGRESS OF WATER
0	No protection	No protection
1	Protected against solid foreign objects of 50 mm Ø and greater	Protected against vertically falling water drops
2	Protected against solid foreign objects of 12.5 mm Ø and greater	Protected against vertically falling water drops when enclosure tilted up to 15°
3	Protected against solid foreign objects of 2.5 mm Ø and greater	Protected against spraying water
4	Protected against solid foreign objects of 1 mm Ø and greater	Protected against splashing water
5	Dust-protected	Protected against water jets
6	Dust-tight	Protected against powerful water jets

LVAC Power Capacitors Terminal Block With Spring Connection

ESTAspring



FEATURES

- Maintenance free
- Reduced assembly times up to 60 %
- Vibration proof in wind power plants and during transport
- Optical connection check:
lever closed = successfully contacted
- 2.5 mm² up to 25 mm² with wire-end sleeve
- Defined continuous contact force through spring technology
- Stainless steel spring
- Corrosion proof
- Fast and easy lever-operated wire connection
- Copper alloy for conductor material
- UL and cUL

APPLICATIONS

- Wind power plants
- Solar panels and inverters
- Thermal power station
- Power factor correction $\leq 1000 \text{ VAC}_{\text{RMS}}$
- Harmonic filter



RoHS
COMPLIANT
HALOGEN
FREE
GREEN
(5-2008)

QUICK REFERENCE DATA	
Series	PhMKP With ESTAspring
Description	LVAC Power Capacitors - Oil and Dry - INDOOR, IP20
Type	Capacitors, fixed, low voltage
Technology	MKP, metallized polypropylene film
Voltage max. (V)	1000
Capacitance min. (μF)	3-phase D: 3 x 11.5, 3-phase Y: 3 x 83.6, 1-phase: 49.7
Capacitance max. (μF)	3-phase D: 3 x 335.0, 3-phase Y: 3 x 219.3, 1-phase: 332.2
Output min. (kvar)	2
Output max. (kvar)	37.1



CAPACITORS IN CYLINDRICAL CASINGS

APPLICATION

The Vishay ESTA PhMKP / PhMKPg series of power factor correction capacitors in cylindrical aluminum casings is available in 64 mm, 84 mm, 116 mm, and 136 mm diameter designs.

The 116 mm and 136 mm start where the output of the 84 mm design ends. At the point of change, the customer has two options: the lower height profile of the 116 mm and 136 mm or the slimmer diameter of the 84.4 mm design.

The Vishay ESTA LVAC capacitors are suitable for use in both standard PFC applications and in heavy-duty applications such as wind turbines:

- automatic PFC equipment
- individual fixed PFC (e.g. motors, transformers, lighting)
- group fixed PFC
- tuned and detuned capacitor banks
- harmonic filters (e.g. UPS, frequency drives, converters)

DESIGN

The Vishay ESTA LVAC MKP capacitors are metallized polypropylene film capacitors with self-healing properties. The current-carrying metal layer of an MKP capacitor is vaporized onto one side of the polypropylene film. The front surface of tubular winding elements are joined by means of the metal spray method (schooping). Three winding elements are encapsulated in one aluminum casing and connected to form a true 3-phase capacitor. The overpressure tear-off fuse prevents the capacitor from bursting at the end of service life, or due to inadmissible electrical or thermal overloads.

The capacitor is housed in a tubular aluminum container with an aluminum lid press-rolled onto it. The current is supplied via a ESTAspring IP20 block-type safety terminal. A threaded stud (M12) at the bottom of the container serves for both grounding and mounting.

The Vishay ESTAprop and ESTAdry capacitors will be delivered together with discharge resistors and hardware for mounting.

The entire range of Vishay ESTA LVAC products are offered in both natural oil-filled ESTAprop PhMKP and gas-filled ESTAdry PhMKPg versions.

1-PHASE / 3-PHASE CAPACITOR, ESTAspring IP20 TERMINAL BLOCK 64 mm / 84.4 mm DIAMETER

ESTAspring



3-PHASE CAPACITOR, ESTAspring IP20 TERMINAL BLOCK 116 mm DIAMETER

ESTAspring





CAPACITORS IN CYLINDRICAL CASINGS

TECHNICAL DATA	
STANDARDS	IEC 60831-1 + 2, EN 60831- 1 + 2, UL 810 LATEST EDITIONS, UL / ULC - FILE E97723
Overvoltages (in accordance with the above standards)	U _{cn} + 10 % (up to 8 h daily) U _{cn} + 15 % (up to 30 min daily) U _{cn} + 20 % (up to 5 min, only 200 times in the life of the capacitor) U _{cn} + 30 % (up to 1 min, only 200 times in the life of the capacitor) Please also refer to "Terms and Definitions"
Overcurrent (in accordance with the above standards)	1.3 x I _n 1.43 x I _n with 10 % overvoltages, 10 % over capacitance and harmonics included, continuous operation Please also refer to "Terms and Definitions"
Tolerance on capacitance	-5 % / +10 % in accordance with the standards ± 5 % as Vishay ESTA standard
Test voltage, terminal / terminal	2.15 x U _{cn} , VAC, 2 s (routine test)
Test voltage, terminal / casing	4800 VAC, 2 s (routine test)
Inrush current	300 times rated current I _n
Losses	≤ 0.25 W/kvar to 0.45 W/kvar (without discharge resistors)
Statistical life expectancy ⁽¹⁾	> 150 000 operating h (ESTAprop) > 130 000 operating h (ESTAdry)
Degree of protection	ESTAspring IP20 terminal, indoor
Ambient temperature category	-40 / D (max. 55 °C) ESTAprop, -40 / D (max. 55 °C) ESTAdry
Permitted casing temperature	Max. 65 °C (measured on top of the can)
Cooling	Naturally air-cooled
Permissible relative humidity	Maximum 95 %
Maximum allowed altitude	2000 m above sea level
Mounting position	Vertical and horizontal
Terminal	ESTAspring fast and easy lever-operated spring loaded terminal, 2.5 mm ² up to 25 mm ² cable cross section with wire-end sleeve
Mounting and grounding	Threaded M12 stud at the bottom of the container
Safety features	All-phase overpressure tear-off fuse, self-healing
Casing	Aluminum can
Dielectric	Polypropylene film, self-healing
Filling agent	Natural oil, non-PCB, biodegradable (ESTAprop) or dry / gas - filled (ESTAdry)

Note

⁽¹⁾ Statements about product lifetime are based on calculations and internal testing. They should only be interpreted as estimations. Also due to external factors, the lifetime in the field application may deviate from the calculated lifetime. In general, nothing stated herein shall be construed as a guarantee of quality or durability



CAPACITORS WITH ESTAspring

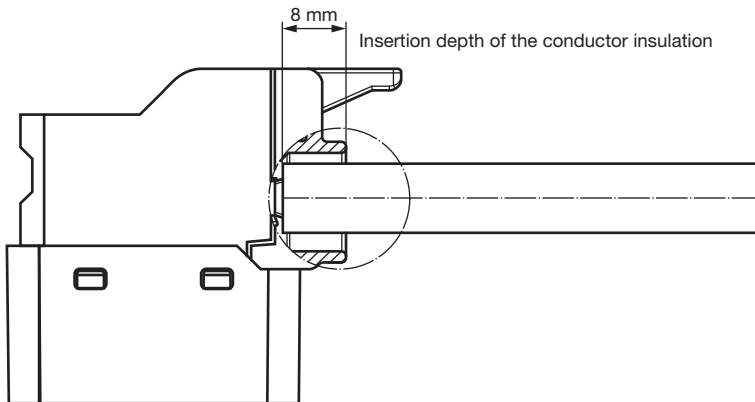
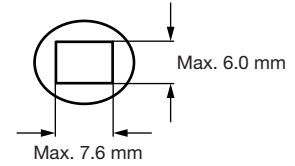
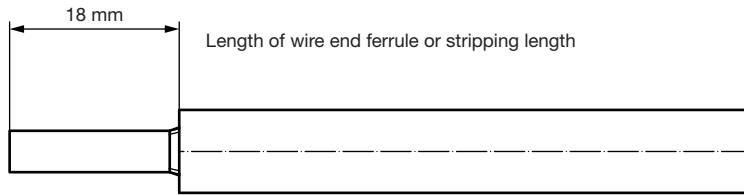

Transverse ok



Upended wrong

STANDARDS FOR ESTAspring TERMINAL BLOCK

- Conductor pull-out test according to IEC 60998-2-1
- Impulse withstand voltage test according to IEC 60664-1
- Current carrying capacity up to 90 A/phase according to IEC 60512-5-2
- Vibration test according to IEC 60068-2-6
- Corrosion test according to IEC 6988
- Temperature shock test according to IEC 60512-11-4, clause 11d
- Degree of protection IP20, test according to DIN 40050-9/60529

The lever is designed for a minimum of 10 operating cycles. Continuous use can result in excessive wear.



3-PHASE CAPACITORS ESTAspring

IP20, OIL

RATED VOLTAGE 230 V, 50 Hz, DELTA CONNECTION, UL / ULC							
TYPE	ARTICLE NO. ⁽¹⁾	OUTPUT kvar	CAP. μ F	CURRENT A	DIMENSIONS \varnothing x H mm	WEIGHT kg	DRAWING NO.
PhMKP230.3.02,50-S64	5341-48100-xx	2.5	3 x 50.1	6.3	64 x 190	0.8	1
PhMKP230.3.05,00-S64	5341-48101-xx	5	3 x 100.3	12.6	64 x 265	1.0	1
PhMKP230.3.10,00-S84	5341-48800-xx	10	3 x 200.6	25.1	84.4 x 265	1.7	2
PhMKP230.3.12,50-S84	5341-48801-xx	12.5	3 x 250.7	31.4	84.4 x 340	2.0	2
PhMKP230.3.15,00-S84	5341-48802-xx	15	3 x 300.9	37.7	84.4 x 340	2.1	2
PhMKP230.3.10,00-S116	5341-47103-xx	10	3 x 200.6	25.1	116 x 160	2.1	3
PhMKP230.3.12,50-S116	5341-47104-xx	12.5	3 x 250.7	31.4	116 x 190	2.5	3
PhMKP230.3.15,00-S116	5341-47105-xx	15	3 x 300.9	37.7	116 x 190	2.5	3
PhMKP230.3.16,70-S116	5341-47106-xx	16.7	3 x 335.0	41.9	116 x 230	3.1	3

RATED VOLTAGE 400 V, 50 Hz, DELTA CONNECTION, UL / ULC								
CAN BE USED ALSO FOR 415 V, FULL OVER VOLTAGE RANGE								
TYPE	ARTICLE NO. ⁽¹⁾	OUTPUT kvar 400 V	OUTPUT kvar 415 V	CAP. μ F	CURRENT A 400 V / 415 V	DIMENSIONS \varnothing x H mm	WEIGHT kg	DRAWING NO.
PhMKP400.3.02,50-S64	5341-48102-xx	2.5	2.7	3 x 16.6	3.6 / 3.7	64 x 190	0.8	1
PhMKP400.3.05,00-S64	5341-48103-xx	5	5.4	3 x 33.2	7.2 / 7.5	64 x 190	0.8	1
PhMKP400.3.06,67-S64	5341-48104-xx	6.67	7.2	3 x 44.2	9.6 / 10.0	64 x 190	0.8	1
PhMKP400.3.07,50-S64	5341-48105-xx	7.5	8.1	3 x 49.7	10.8 / 11.2	64 x 190	0.8	1
PhMKP400.3.08,33-S64	5341-48106-xx	8.33	9.0	3 x 55.2	12 / 12.5	64 x 190	0.8	1
PhMKP400.3.10,00-S64	5341-48107-xx	10	10.8	3 x 66.3	14.4 / 14.9	64 x 265	1.0	1
PhMKP400.3.12,50-S64	5341-48108-xx	12.5	13.5	3 x 82.9	18 / 18.7	64 x 265	1.0	1
PhMKP400.3.10,00-S84	5341-48803-xx	10	10.8	3 x 66.3	14.4 / 14.9	84.4 x 190	1.3	2
PhMKP400.3.12,50-S84	5341-48804-xx	12.5	13.5	3 x 82.9	18 / 18.7	84.4 x 190	1.3	2
PhMKP400.3.15,00-S84	5341-48805-xx	15	16.1	3 x 99.5	21.6 / 22.4	84.4 x 190	1.3	2
PhMKP400.3.16,70-S84	5341-48806-xx	16.7	18.0	3 x 110.7	24.1 / 25.0	84.4 x 265	1.7	2
PhMKP400.3.20,00-S84	5341-48807-xx	20	21.5	3 x 132.6	28.8 / 30.0	84.4 x 265	1.7	2
PhMKP400.3.25,00-S84	5341-48808-xx	25	26.9	3 x 165.8	36.1 / 37.4	84.4 x 265	1.7	2
PhMKP400.3.16,70-S116	5341-47110-xx	16.7	18.0	3 x 110.7	24.1 / 25.0	116 x 160	2.1	3
PhMKP400.3.20,00-S116	5341-47111-xx	20	21.5	3 x 132.6	28.8 / 29.9	116 x 160	2.1	3
PhMKP400.3.25,00-S116	5341-47112-xx	25	26.9	3 x 165.8	36.1 / 37.4	116 x 190	2.5	3

Notes

- Other voltage ratings, outputs, and frequencies upon request. All PhMKP-type capacitors may be also be applied in 60 Hz networks, output and current will, however, be 20 % higher in these cases (i.e. additional thermal load and therefore, a lower class of temperature must be taken into account)

⁽¹⁾ Version no. xx may differ as it respects small changes, e.g. on the label



3-PHASE CAPACITORS ESTAspring

IP20, OIL

RATED VOLTAGE 440 V, 50 Hz, DELTA CONNECTION, UL / ULC								
CAN BE USED ALSO FOR 415 V								
TYPE	ARTICLE NO. ⁽¹⁾	OUTPUT kvar 440 V	OUTPUT kvar 415 V	CAP. µF	CURRENT A 440 V / 415 V	DIMENSIONS Ø x H mm	WEIGHT kg	DRAWING NO.
PhMKP440.3.02,50-S64	5341-48122-xx	2.5	2.2	3 x 13.7	3.3 / 3.1	64 x 190	0.7	1
PhMKP440.3.05,00-S64	5341-48109-xx	5	4.4	3 x 27.4	6.6 / 6.1	64 x 190	0.8	1
PhMKP440.3.08,33-S64	5341-48110-xx	8.33	7.4	3 x 45.7	10.9 / 10.3	64 x 190	0.8	1
PhMKP440.3.10,00-S64	5341-48111-xx	10	8.9	3 x 54.8	13.1 / 12.4	64 x 265	1.0	1
PhMKP440.3.11,20-S64	5341-48112-xx	11.2	10	3 x 61.4	14.7 / 13.9	64 x 265	1.0	1
PhMKP440.3.12,50-S64	5341-48113-xx	12.5	11.1	3 x 68.5	16.4 / 15.4	64 x 265	1.0	1
PhMKP440.3.14,00-S64	5341-48114-xx	14	12.5	3 x 76.7	18.4 / 17.4	64 x 265	1.0	1
PhMKP440.3.12,50-S84	5341-48809-xx	12.5	11.1	3 x 68.5	16.4 / 15.5	84.4 x 190	1.3	2
PhMKP440.3.14,10-S84	5341-48810-xx	14.1	12.5	3 x 77.0	18.5 / 17.5	84.4 x 190	1.3	2
PhMKP440.3.15,00-S84	5341-48811-xx	15	13.3	3 x 82.2	19.7 / 18.6	84.4 x 190	1.3	2
PhMKP440.3.16,90-S84	5341-48812-xx	16.9	15	3 x 92.6	22.2 / 20.9	84.4 x 190	1.3	2
PhMKP440.3.18,80-S84	5341-48813-xx	18.8	16.67	3 x 103.0	24.7 / 23.3	84.4 x 265	1.7	2
PhMKP440.3.20,00-S84	5341-48814-xx	20	17.8	3 x 109.6	26.2 / 24.8	84.4 x 265	1.7	2
PhMKP440.3.22,50-S84	5341-48815-xx	22.5	20	3 x 123.3	29.5 / 27.8	84.4 x 265	1.7	2
PhMKP440.3.25,00-S84	5341-48816-xx	25	22.2	3 x 137.0	32.8 / 30.9	84.4 x 265	1.7	2
PhMKP440.3.28,10-S84	5341-48817-xx	28.1	25	3 x 154.0	36.9 / 34.8	84.4 x 265	1.7	2
PhMKP440.3.30,00-S84	5341-48818-xx	30	26.7	3 x 164.4	39.4 / 37.1	84.4 x 340	2.1	2
PhMKP440.3.14,10-S116	5341-47168-xx	14.1	12.5	3 x 77.0	18.5 / 17.5	116 x 160	1.5	3
PhMKP440.3.18,80-S116	5341-47115-xx	18.8	16.67	3 x 103.0	24.7 / 23.3	116 x 160	1.8	3
PhMKP440.3.20,00-S116	5341-47116-xx	20	17.8	3 x 109.6	26.2 / 24.8	116 x 160	1.8	3
PhMKP440.3.22,50-S116	5341-47117-xx	22.5	20	3 x 123.3	29.5 / 27.8	116 x 160	1.9	3
PhMKP440.3.25,00-S116	5341-47118-xx	25	22.2	3 x 137.0	32.8 / 30.9	116 x 190	2.0	3
PhMKP440.3.28,10-S116	5341-47120-xx	28.1	25	3 x 154.0	36.9 / 34.8	116 x 190	2.0	3
PhMKP440.3.30,00-S116	5341-47122-xx	30	26.7	3 x 164.4	39.4 / 37.1	116 x 190	2.2	3

Notes

- Other voltage ratings, outputs, and frequencies upon request. All PhMKP-type capacitors may be also be applied in 60 Hz networks, output and current will, however, be 20 % higher in these cases (i.e. additional thermal load and therefore, a lower class of temperature must be taken into account)

⁽¹⁾ Version no. xx may differ as it respects small changes, e.g. on the label



3-PHASE CAPACITORS ESTAspring

IP20, OIL

RATED VOLTAGE 525 V, 50 Hz, DELTA CONNECTION, UL / ULC								
CAN BE USED ALSO FOR 480 V								
TYPE	ARTICLE NO. ⁽¹⁾	OUTPUT kvar 525 V	OUTPUT kvar 480 V	CAP. μF	CURRENT A 525 V / 480 V	DIMENSIONS Ø x H mm	WEIGHT kg	DRAWING NO.
PhMKP525.3.03,00-S64	5341-48115-xx	3	2.5	3 x 11.5	3.3 / 3.0	64 x 190	0.8	1
PhMKP525.3.05,00-S64	5341-48116-xx	5	4.2	3 x 19.2	5.5 / 5.0	64 x 190	0.8	1
PhMKP525.3.08,33-S64	5341-48117-xx	8.33	7	3 x 32.1	9.2 / 8.4	64 x 190	0.8	1
PhMKP525.3.10,00-S64	5341-48118-xx	10	8.33	3 x 38.5	11.0 / 10.1	64 x 265	1.0	1
PhMKP525.3.10,00-S84	5341-48819-xx	10	8.33	3 x 38.5	11.0 / 10.1	84.4 x 190	1.3	2
PhMKP525.3.12,50-S84	5341-48820-xx	12.5	10.4	3 x 48.1	13.7 / 12.6	84.4 x 190	1.3	2
PhMKP525.3.13,80-S84	5341-48821-xx	13.8	11.5	3 x 53.1	15.2 / 13.8	84.4 x 190	1.3	2
PhMKP525.3.15,00-S84	5341-48822-xx	15	12.5	3 x 57.7	16.5 / 15.0	84.4 x 190	1.3	2
PhMKP525.3.20,00-S84	5341-48823-xx	20	16.7	3 x 77.0	22.0 / 20.1	84.4 x 265	1.7	2
PhMKP525.3.25,00-S84	5341-48824-xx	25	20.9	3 x 96.2	27.5 / 25.1	84.4 x 265	1.7	2
PhMKP525.3.20,00-S116	5341-47124-xx	20	16.7	3 x 77.0	22.0 / 20.1	116 x 160	1.8	3
PhMKP525.3.25,00-S116	5341-47125-xx	25	20.9	3 x 96.2	27.5 / 25.1	116 x 190	2.5	3
PhMKP525.3.30,00-S116	5341-47169-xx	30	25.1	3 x 115.4	33.0 / 30.2	116 x 230	2.6	3
PhMKP525.3.35,90-S116	5341-47170-xx	35.9	30	3 x 138.2	39.5 / 36.1	116 x 265	2.8	3
PhMKP525.3.37,10-S116	5341-47165-xx	37.1	31	3 x 142.8	40.8 / 37.3	116 x 265	2.8	3

Notes

- Other voltage ratings, outputs, and frequencies upon request. All PhMKP-type capacitors may be also be applied in 60 Hz networks, output and current will, however, be 20 % higher in these cases (i.e. additional thermal load and therefore, a lower class of temperature must be taken into account)
- (1) Version no. xx may differ as it respects small changes, e.g. on the label



3-PHASE CAPACITORS ESTAspring

IP20, OIL

RATED VOLTAGE 660 V, 50 Hz, 64 / 84: DELTA CONNECTION, 116: STAR CONNECTION, UL / ULC UP TO 660 V								
CAN BE USED ALSO FOR 690 V								
TYPE	ARTICLE NO. (1)	OUTPUT kvar 660 V	OUTPUT kvar 690 V	CAP. µF	CURRENT A 660 V / 690 V	DIMENSIONS Ø x H mm	WEIGHT kg	DRAWING NO.
PhMKP660.3.05,00-S64	5341-48119-xx	5	5.5	3 x 12.2	4.4 / 4.6	64 x 190	0.8	1
PhMKP660.3.08,33-S64	5341-48120-xx	8.33	9.1	3 x 20.3	7.3 / 7.6	64 x 265	1.0	1
PhMKP660.3.08,33-S84	5341-48825-xx	8.33	9.1	3 x 20.3	7.3 / 7.6	84.4 x 190	1.3	2
PhMKP660.3.10,00-S84	5341-48826-xx	10	10.9	3 x 24.4	8.7 / 9.1	84.4 x 190	1.3	2
PhMKP660.3.12,50-S84	5341-48827-xx	12.5	13.7	3 x 30.4	10.9 / 11.4	84.4 x 265	1.7	2
PhMKP660.3.15,00-S84	5341-48828-xx	15	16.4	3 x 36.5	13.1 / 13.7	84.4 x 265	1.7	2
PhMKP660.3.16,70-S84	5341-48829-xx	16.7	18.3	3 x 40.7	14.6 / 15.3	84.4 x 265	1.7	2
PhMKP660.3.20,00-S84	5341-48830-xx	20	21.9	3 x 48.7	17.5 / 18.3	84.4 x 340	2.1	2
PhMKP660.3.22,90-S84	5341-48831-xx	22.9	25	3 x 55.8	20 / 20.9	84.4 x 340	2.1	2
PhMKP660.2.12,50-S116	5341-47157-xx	12.5	13.7	3 x 91.4	10.9 / 11.4	116 x 160	2.1	3
PhMKP660.2.15,00-S116	5341-47158-xx	15	16.4	3 x 109.6	13.1 / 13.7	116 x 160	2.1	3
PhMKP660.2.16,70-S116	5341-47159-xx	16.7	18.3	3 x 122.1	14.6 / 15.3	116 x 160	2.1	3
PhMKP660.2.20,00-S116	5341-47161-xx	20	21.9	3 x 146.2	17.5 / 18.3	116 x 190	2.3	3
PhMKP660.2.22,90-S116	5341-47162-xx	22.9	25	3 x 167.3	20 / 20.9	116 x 190	2.5	3

RATED VOLTAGE 690 V, 50 Hz, 64 / 84: DELTA CONNECTION, 116: STAR CONNECTION								
CAN BE USED ALSO FOR 660 V								
TYPE	ARTICLE NO. (1)	OUTPUT kvar 690 V	OUTPUT kvar 660 V	CAP. µF	CURRENT A 690 V / 660 V	DIMENSIONS Ø x H mm	WEIGHT kg	DRAWING NO.
PhMKP690.3.10,00-S64	5341-48121-xx	10	9.1	3 x 22.3	8.4 / 8.0	64 x 265	1.1	1
PhMKP690.3.12,50-S84	5341-48832-xx	12.5	11.4	3 x 27.9	10.5 / 10.0	84.4 x 265	1.9	2
PhMKP690.3.15,00-S84	5341-48833-xx	15	13.7	3 x 33.4	12.5 / 12.0	84.4 x 265	1.9	2
PhMKP690.3.20,00-S84	5341-48834-xx	20	18.3	3 x 44.6	16.7 / 16.0	84.4 x 340	2.4	2
PhMKP690.3.25,00-S84	5341-48835-xx	25	22.9	3 x 55.7	20.9 / 20.0	84.4 x 340	2.4	2
PhMKP690.2.12,50-S116	5341-47171-xx	12.5	11.4	3 x 83.6	10.5 / 10.0	116 x 160	2.0	3
PhMKP690.2.15,00-S116	5341-47172-xx	15	13.7	3 x 100.3	12.5 / 12.0	116 x 160	2.2	3
PhMKP690.2.20,00-S116	5341-47173-xx	20	18.3	3 x 133.7	16.7 / 16.0	116 x 190	2.2	3
PhMKP690.2.25,00-S116	5341-47174-xx	25	22.9	3 x 167.3	20.9 / 20.0	116 x 190	2.5	3

Notes

- Other voltage ratings, outputs, and frequencies upon request. All PhMKP-type capacitors may be also be applied in 60 Hz networks, output and current will, however, be 20 % higher in these cases (i.e. additional thermal load and therefore, a lower class of temperature must be taken into account)
- (1) Version no. xx may differ as it respects small changes, e.g. on the label



3-PHASE CAPACITORS ESTAspring

IP20, DRY

RATED VOLTAGE 230 V, 50 Hz, DELTA CONNECTION, UL / ULC							
TYPE	ARTICLE NO. (1)	OUTPUT kvar	CAP. μ F	CURRENT A	DIMENSIONS \varnothing x H mm	WEIGHT kg	DRAWING NO.
PhMKPg230.3.02,50-S64	5343-48400-xx	2.5	3 x 50.1	6.3	64 x 190	0.6	1
PhMKPg230.3.05,00-S64	5343-48401-xx	5	3 x 100.3	12.6	64 x 265	0.8	1
PhMKPg230.3.10,00-S84	5343-48700-xx	10	3 x 200.6	25.1	84.4 x 265	1.4	2
PhMKPg230.3.12,50-S84	5343-48701-xx	12.5	3 x 250.7	31.4	84.4 x 340	1.5	2
PhMKPg230.3.15,00-S84	5343-48702-xx	15	3 x 300.9	37.7	84.4 x 340	1.7	2
PhMKPg230.3.10,00-S116	5343-47306-xx	10	3 x 200.6	25.1	116 x 160	1.5	3
PhMKPg230.3.12,50-S116	5343-47307-xx	12.5	3 x 250.7	31.4	116 x 190	1.7	3
PhMKPg230.3.15,00-S116	5343-47308-xx	15	3 x 300.9	37.7	116 x 190	1.9	3
PhMKPg230.3.16,70-S116	5343-47309-xx	16.7	3 x 335.0	41.9	116 x 230	2.2	3

RATED VOLTAGE 400 V, 50 Hz, DELTA CONNECTION, UL / ULC								
CAN BE USED ALSO FOR 415 V, FULL OVER VOLTAGE RANGE								
TYPE	ARTICLE NO. (1)	OUTPUT kvar 400 V	OUTPUT kvar 415 V	CAP. μ F	CURRENT A 400 V / 415 V	DIMENSIONS \varnothing x H mm	WEIGHT kg	DRAWING NO.
PhMKPg400.3.02,50-S64	5343-48402-xx	2.5	2.7	3 x 16.6	3.6 / 3.7	64 x 190	0.6	1
PhMKPg400.3.05,00-S64	5343-48403-xx	5	5.4	3 x 33.2	7.2 / 7.5	64 x 190	0.6	1
PhMKPg400.3.06,67-S64	5343-48404-xx	6.67	7.2	3 x 44.2	9.6 / 10.0	64 x 190	0.6	1
PhMKPg400.3.07,50-S64	5343-48405-xx	7.5	8.1	3 x 49.7	10.8 / 11.2	64 x 190	0.6	1
PhMKPg400.3.08,33-S64	5343-48406-xx	8.33	9.0	3 x 55.2	12 / 12.5	64 x 190	0.7	1
PhMKPg400.3.10,00-S64	5343-48407-xx	10	10.8	3 x 66.3	14.4 / 14.9	64 x 265	0.7	1
PhMKPg400.3.12,50-S64	5343-48408-xx	12.5	13.5	3 x 82.9	18 / 18.7	64 x 265	0.8	1
PhMKPg400.3.10,00-S84	5343-48703-xx	10	10.8	3 x 66.3	14.4 / 14.9	84.4 x 190	1.0	2
PhMKPg400.3.12,50-S84	5343-48704-xx	12.5	13.5	3 x 82.9	18 / 18.7	84.4 x 190	1.4	2
PhMKPg400.3.15,00-S84	5343-48705-xx	15	16.1	3 x 99.5	21.6 / 22.4	84.4 x 190	1.4	2
PhMKPg400.3.16,70-S84	5343-48706-xx	16.7	18.0	3 x 110.7	24.1 / 25.0	84.4 x 265	1.4	2
PhMKPg400.3.20,00-S84	5343-48707-xx	20	21.5	3 x 132.6	28.8 / 30.0	84.4 x 265	1.4	2
PhMKPg400.3.25,00-S84	5343-48708-xx	25	26.9	3 x 165.8	36.1 / 37.4	84.4 x 265	1.5	2
PhMKPg400.3.16,70-S116	5343-47312-xx	16.7	18.0	3 x 110.7	24.1 / 25.0	116 x 160	1.5	3
PhMKPg400.3.20,00-S116	5343-47313-xx	20	21.5	3 x 132.6	28.8 / 29.9	116 x 160	1.6	3
PhMKPg400.3.25,00-S116	5343-47315-xx	25	26.9	3 x 165.8	36.1 / 37.4	116 x 190	1.9	3

Notes

- Other voltage ratings, outputs, and frequencies upon request. All PhMKP-type capacitors may be also be applied in 60 Hz networks, output and current will, however, be 20 % higher in these cases (i.e. additional thermal load and therefore, a lower class of temperature must be taken into account)
- (1) Version no. xx may differ as it respects small changes, e.g. on the label



3-PHASE CAPACITORS ESTAspring

IP20, DRY

RATED VOLTAGE 440 V, 50 Hz, DELTA CONNECTION, UL / ULC								
CAN BE USED ALSO FOR 415 V								
TYPE	ARTICLE NO. ⁽¹⁾	OUTPUT kvar 440 V	OUTPUT kvar 415 V	CAP. µF	CURRENT A 440 V / 415 V	DIMENSIONS Ø x H mm	WEIGHT kg	DRAWING NO.
PhMKPg440.3.02,50-S64	5343-48422-xx	2.5	2.2	3 x 13.7	3.3 / 3.1	64 x 190	0.6	1
PhMKPg440.3.05,00-S64	5343-48409-xx	5	4.4	3 x 27.4	6.6 / 6.1	64 x 190	0.6	1
PhMKPg440.3.08,33-S64	5343-48410-xx	8.33	7.4	3 x 45.7	10.9 / 10.3	64 x 190	0.6	1
PhMKPg440.3.10,00-S64	5343-48411-xx	10	8.9	3 x 54.8	13.1 / 12.4	64 x 265	0.8	1
PhMKPg440.3.11,20-S64	5343-48412-xx	11.2	10	3 x 61.4	14.7 / 13.9	64 x 265	0.8	1
PhMKPg440.3.12,50-S64	5343-48413-xx	12.5	11.1	3 x 68.5	16.4 / 15.4	64 x 265	0.8	1
PhMKPg440.3.14,00-S64	5343-48414-xx	14	12.5	3 x 76.7	18.4 / 17.4	64 x 265	1.0	1
PhMKPg440.3.12,50-S84	5343-48709-xx	12.5	11.1	3 x 68.5	16.4 / 15.5	84.4 x 190	1.0	2
PhMKPg440.3.14,10-S84	5343-48710-xx	14.1	12.5	3 x 77.0	18.5 / 17.5	84.4 x 190	1.1	2
PhMKPg440.3.15,00-S84	5343-48711-xx	15	13.3	3 x 82.2	19.7 / 18.6	84.4 x 190	1.1	2
PhMKPg440.3.16,90-S84	5343-48712-xx	16.9	15	3 x 92.6	22.2 / 20.9	84.4 x 190	1.2	2
PhMKPg440.3.18,80-S84	5343-48713-xx	18.8	16.67	3 x 103.0	24.7 / 23.3	84.4 x 265	1.3	2
PhMKPg440.3.20,00-S84	5343-48714-xx	20	17.8	3 x 109.6	26.2 / 24.8	84.4 x 265	1.4	2
PhMKPg440.3.22,50-S84	5343-48715-xx	22.5	20	3 x 123.3	29.5 / 27.8	84.4 x 265	1.4	2
PhMKPg440.3.25,00-S84	5343-48716-xx	25	22.2	3 x 137.0	32.8 / 30.9	84.4 x 265	1.5	2
PhMKPg440.3.28,10-S84	5343-48717-xx	28.1	25	3 x 154.0	36.9 / 34.8	84.4 x 265	1.5	2
PhMKPg440.3.30,00-S84	5343-48718-xx	30	26.7	3 x 164.4	39.4 / 37.1	84.4 x 340	1.8	2
PhMKPg440.3.14,10-S116	5343-47369-xx	14.1	12.5	3 x 77.0	18.5 / 17.5	116 x 160	1.0	3
PhMKPg440.3.18,80-S116	5343-47317-xx	18.8	16.67	3 x 103.0	24.7 / 23.3	116 x 160	1.5	3
PhMKPg440.3.20,00-S116	5343-47318-xx	20	17.8	3 x 109.6	26.2 / 24.8	116 x 160	1.6	3
PhMKPg440.3.22,50-S116	5343-47319-xx	22.5	20	3 x 123.3	29.5 / 27.8	116 x 160	1.6	3
PhMKPg440.3.25,00-S116	5343-47320-xx	25	22.2	3 x 137.0	32.8 / 30.9	116 x 190	1.7	3
PhMKPg440.3.28,10-S116	5343-47305-xx	28.1	25	3 x 154.0	36.9 / 34.8	116 x 190	1.6	3

Notes

- Other voltage ratings, outputs, and frequencies upon request. All PhMKP-type capacitors may be also be applied in 60 Hz networks, output and current will, however, be 20 % higher in these cases (i.e. additional thermal load and therefore, a lower class of temperature must be taken into account)
- (1) Version no. xx may differ as it respects small changes, e.g. on the label



3-PHASE CAPACITORS ESTAspring

IP20, DRY

RATED VOLTAGE 525 V, 50 Hz, DELTA CONNECTION, UL / ULC								
CAN BE USED ALSO FOR 480 V								
TYPE	ARTICLE NO. ⁽¹⁾	OUTPUT kvar 525 V	OUTPUT kvar 480 V	CAP. μ F	CURRENT A 525 V / 480 V	DIMENSIONS \varnothing x H mm	WEIGHT kg	DRAWING NO.
PhMKPg525.3.03,00-S64	5343-48415-xx	3	2.5	3 x 11.5	3.3 / 3.0	64 x 190	0.6	1
PhMKPg525.3.05,00-S64	5343-48416-xx	5	4.2	3 x 19.2	5.5 / 5.0	64 x 190	0.6	1
PhMKPg525.3.08,33-S64	5343-48417-xx	8.33	7	3 x 32.1	9.2 / 8.4	64 x 190	0.6	1
PhMKPg525.3.10,00-S64	5343-48418-xx	10	8.33	3 x 38.5	11.0 / 10.1	64 x 265	0.7	1
PhMKPg525.3.10,00-S84	5343-48719-xx	10	8.33	3 x 38.5	11.0 / 10.1	84.4 x 190	0.8	2
PhMKPg525.3.12,50-S84	5343-48720-xx	12.5	10.4	3 x 48.1	13.7 / 12.6	84.4 x 190	1.0	2
PhMKPg525.3.13,80-S84	5343-48721-xx	13.8	11.5	3 x 53.1	15.2 / 13.8	84.4 x 190	1.0	2
PhMKPg525.3.15,00-S84	5343-48722-xx	15	12.5	3 x 57.7	16.5 / 15.0	84.4 x 190	1.2	2
PhMKPg525.3.20,00-S84	5343-48723-xx	20	16.7	3 x 77.0	22.0 / 20.1	84.4 x 265	1.3	2
PhMKPg525.3.25,00-S84	5343-48724-xx	25	20.9	3 x 96.2	27.5 / 25.1	84.4 x 265	1.5	2
PhMKPg525.3.20,00-S116	5343-47366-xx	20	16.7	3 x 77.0	22.0 / 20.1	116 x 160	1.4	3
PhMKPg525.3.25,00-S116	5343-47327-xx	25	20.9	3 x 96.2	27.5 / 25.1	116 x 190	1.5	3
PhMKPg525.3.30,00-S116	5343-47367-xx	30	25.1	3 x 115.4	33.0 / 30.2	116 x 230	2.0	3
PhMKPg525.3.35,90-S116	5343-47371-xx	35.9	30	3 x 138.2	39.5 / 36.1	116 x 265	2.1	3
PhMKPg525.3.37,10-S116	5343-47372-xx	37.1	31	3 x 142.8	40.8 / 37.3	116 x 265	2.2	3

Notes

- Other voltage ratings, outputs, and frequencies upon request. All PhMKP-type capacitors may be also be applied in 60 Hz networks, output and current will, however, be 20 % higher in these cases (i.e. additional thermal load and therefore, a lower class of temperature must be taken into account)
- ⁽¹⁾ Version no. xx may differ as it respects small changes, e.g. on the label



3-PHASE CAPACITORS ESTAspring

IP20, DRY

RATED VOLTAGE 660 V, 50 Hz, 64 / 84: DELTA CONNECTION, 116: STAR CONNECTION, UL / ULC UP TO 660 V								
CAN BE USED ALSO FOR 690 V, FULL OVER VOLTAGE RANGE								
TYPE	ARTICLE NO. ⁽¹⁾	OUTPUT kvar 660 V	OUTPUT kvar 690 V	CAP. µF	CURRENT A 660 V / 690 V	DIMENSIONS Ø x H mm	WEIGHT kg	DRAWING NO.
PhMKPg660.3.05,00-S64	5343-48419-xx	5	5.5	3 x 12.2	4.4 / 4.6	64 x 190	0.6	1
PhMKPg660.3.08,33-S64	5343-48420-xx	8.33	9.1	3 x 20.3	7.3 / 7.6	64 x 265	0.8	1
PhMKPg660.3.08,33-S84	5343-48725-xx	8.33	9.1	3 x 20.3	7.3 / 7.6	84.4 x 190	0.9	2
PhMKPg660.3.10,00-S84	5343-48726-xx	10	10.9	3 x 24.4	8.7 / 9.1	84.4 x 190	1.1	2
PhMKPg660.3.12,50-S84	5343-48727-xx	12.5	13.7	3 x 30.4	10.9 / 11.4	84.4 x 265	1.2	2
PhMKPg660.3.15,00-S84	5343-48728-xx	15	16.4	3 x 36.5	13.1 / 13.7	84.4 x 265	1.4	2
PhMKPg660.3.16,70-S84	5343-48729-xx	16.7	18.3	3 x 40.7	14.6 / 15.3	84.4 x 265	1.5	2
PhMKPg660.3.20,00-S84	5343-48730-xx	20	21.9	3 x 48.7	17.5 / 18.3	84.4 x 340	1.7	2
PhMKPg660.3.22,90-S84	5343-48731-xx	22.9	25	3 x 55.8	20 / 20.9	84.4 x 340	1.9	2
PhMKPg660.2.12,50-S116	5343-47355-xx	12.5	13.7	3 x 91.4	10.9 / 11.4	116 x 160	1.6	3
PhMKPg660.2.15,00-S116	5343-47356-xx	15	16.4	3 x 109.6	13.1 / 13.7	116 x 160	1.6	3
PhMKPg660.2.16,70-S116	5343-47357-xx	16.7	18.3	3 x 122.1	14.6 / 15.3	116 x 160	1.7	3
PhMKPg660.2.20,00-S116	5343-47359-xx	20	21.9	3 x 146.2	17.5 / 18.3	116 x 190	1.8	3
PhMKPg660.2.22,90-S116	5343-47373-xx	22.9	25	3 x 167.3	20 / 20.9	116 x 190	1.7	3

RATED VOLTAGE 690 V, 50 Hz, 64 / 84: DELTA CONNECTION, 116: STAR CONNECTION								
CAN BE USED ALSO FOR 660 V								
TYPE	ARTICLE NO. ⁽¹⁾	OUTPUT kvar 690 V	OUTPUT kvar 660 V	CAP. µF	CURRENT A 690 V / 660 V	DIMENSIONS Ø x H mm	WEIGHT kg	DRAWING NO.
PhMKPg690.3.10,00-S64	5343-48421-xx	10	9.1	3 x 22.3	8.4 / 8.0	64 x 265	0.9	1
PhMKPg690.3.12,50-S84	5343-48732-xx	12.5	11.4	3 x 27.9	10.5 / 10.0	84.4 x 265	1.1	2
PhMKPg690.3.15,00-S84	5343-48733-xx	15	13.7	3 x 33.4	12.5 / 12.0	84.4 x 265	1.3	2
PhMKPg690.3.20,00-S84	5343-48734-xx	20	18.3	3 x 44.6	16.7 / 16.0	84.4 x 340	1.6	2
PhMKPg690.3.25,00-S84	5343-48735-xx	25	22.9	3 x 55.7	20.9 / 20.0	84.4 x 340	1.9	2
PhMKPg690.2.12,50-S116	5343-47374-xx	12.5	11.4	3 x 83.6	10.5 / 10.0	116 x 160	1.2	3
PhMKPg690.2.15,00-S116	5343-47375-xx	15	13.7	3 x 100.3	12.5 / 12.0	116 x 160	1.3	3
PhMKPg690.2.20,00-S116	5343-47376-xx	20	18.3	3 x 133.7	16.7 / 16.0	116 x 190	1.5	3
PhMKPg690.2.25,00-S116	5343-47377-xx	25	22.9	3 x 167.3	20.9 / 20.0	116 x 190	1.6	3

Notes

- Other voltage ratings, outputs, and frequencies upon request. All PhMKPg-type capacitors may be also be applied in 60 Hz networks, output and current will, however, be 20 % higher in these cases (i.e. additional thermal load and therefore, a lower class of temperature must be taken into account)

⁽¹⁾ Version no. xx may differ as it respects small changes, e.g. on the label



1-PHASE CAPACITORS ESTAspring

IP20, OIL

RATED VOLTAGE 230 V, 50 Hz, UL / ULC							
TYPE	ARTICLE NO. ⁽¹⁾	OUTPUT kvar	CAP. μ F	CURRENT A	DIMENSIONS \varnothing x H (mm)	WEIGHT kg	DRAWING NO.
PhMKP230.1.02,50-S64	5341-48142-xx	2.5	150.0	10.9	64 x 140	0.6	1
PhMKP230.1.03,33-S64	5341-48123-xx	3.33	200.4	14.5	64 x 190	0.7	1
PhMKP230.1.04,17-S64	5341-48124-xx	4.17	251.0	18.1	64 x 190	0.8	1
PhMKP230.1.05,00-S84	5341-48838-xx	5	300.0	21.7	84.4 x 140	0.9	2

RATED VOLTAGE 400 V, 50 Hz, UL / ULC								
CAN BE USED ALSO FOR 415 V, FULL OVER VOLTAGE RANGE								
TYPE	ARTICLE NO. ⁽¹⁾	OUTPUT kvar 400 V	OUTPUT kvar 415 V	CAP. μ F	CURRENT A 400 V / 415 V	DIMENSIONS \varnothing x H mm	WEIGHT kg	DRAWING NO.
PhMKP400.1.02,50-S64	5341-48125-xx	2.5	2.7	49.7	6.3 / 6.5	64 x 82	0.3	1
PhMKP400.1.03,33-S64	5341-48126-xx	3.33	3.6	66.2	8.3 / 8.6	64 x 109	0.4	1
PhMKP400.1.05,00-S64	5341-48127-xx	5	5.4	99.5	12.5 / 13.0	64 x 140	0.5	1
PhMKP400.1.06,67-S64	5341-48128-xx	6.67	7.2	132.7	16.7 / 17.3	64 x 190	0.7	1
PhMKP400.1.08,33-S64	5341-48129-xx	8.33	9	165.7	20.8 / 21.6	64 x 190	0.8	1
PhMKP400.1.10,00-S64	5341-48130-xx	10	10.8	198.9	25.0 / 25.9	64 x 240	0.9	1
PhMKP400.1.08,33-S84	5341-48839-xx	8.33	9	165.7	20.8 / 21.6	84.4 x 140	0.9	2
PhMKP400.1.10,00-S84	5341-48840-xx	10	10.8	198.9	25.0 / 25.9	84.4 x 140	1.0	2
PhMKP400.1.16,70-S84	5341-48841-xx	16.7	18	332.2	41.7 / 43.3	84.4 x 240	1.3	2

RATED VOLTAGE 525 V, 50 Hz, UL / ULC								
CAN BE USED ALSO FOR 480 V								
TYPE	ARTICLE NO. ⁽¹⁾	OUTPUT kvar 525 V	OUTPUT kvar 480 V	CAP. μ F	CURRENT A 525 V / 480 V	DIMENSIONS \varnothing x H mm	WEIGHT kg	DRAWING NO.
PhMKP525.1.05,00-S64	5341-48131-xx	5	4.2	57.7	9.5 / 8.8	64 x 140	0.5	1
PhMKP525.1.08,33-S64	5341-48132-xx	8.33	7.0	96.2	15.9 / 14.6	64 x 190	0.7	1
PhMKP525.1.10,00-S64	5341-48133-xx	10	8.4	115.5	19.0 / 17.5	64 x 240	0.9	1
PhMKP525.1.16,70-S84	5341-48842-xx	16.7	14.0	192.9	31.6 / 29.2	84.4 x 240	1.3	2
PhMKP525.1.20,00-S84	5341-48843-xx	20	16.7	231.0	38.0 / 34.8	84.4 x 240	1.3	2

Notes

- Other voltage ratings, outputs, and frequencies upon request. All PhMKP-type capacitors may be also be applied in 60 Hz networks, output and current will, however, be 20 % higher in these cases (i.e. additional thermal load and therefore, a lower class of temperature must be taken into account)
- (1) Version no. xx may differ as it respects small changes, e.g. on the label



DIMENSIONS in millimeters ESTAspring

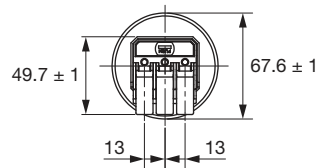
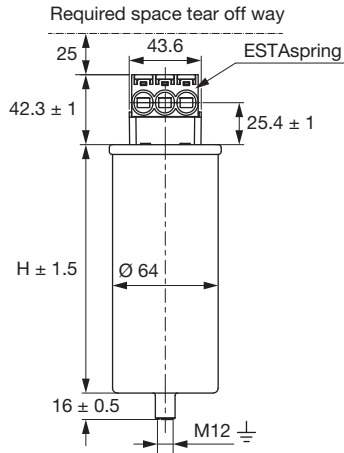

Drawing 1

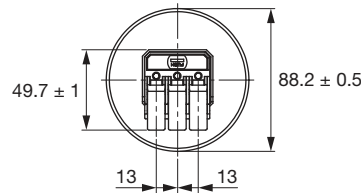
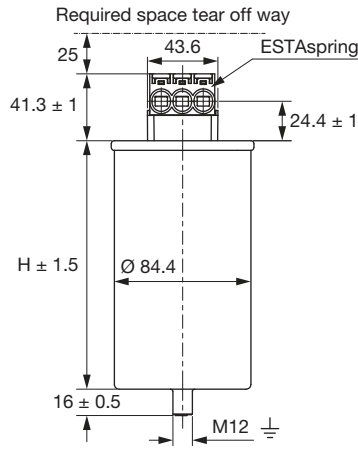

Drawing 2

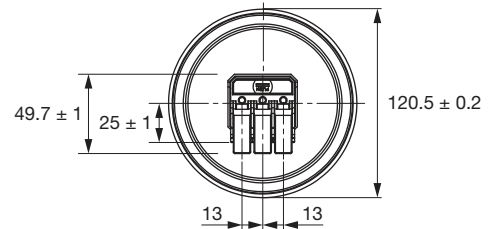
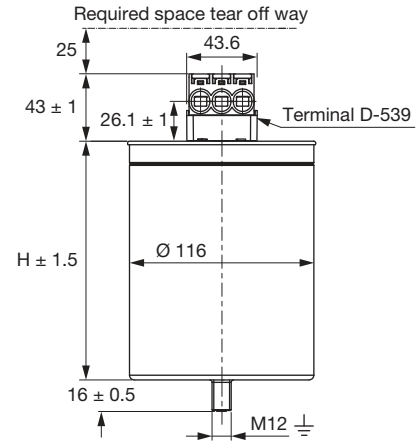

Drawing 3

Note

- Ø 64 / Ø 84, single-phase: middle lever left out

ORDERING INFORMATION

TECHNICAL UNITS

Full cardboard boxes:	Ø 64 mm - 9 pcs per carton
	Ø 84.4 mm - 4 pcs per carton
	Ø 116 mm - 4 pcs per carton









VISHAY INTERTECHNOLOGY, INC.

www.vishay.com



SEMICONDUCTORS

MOSFETs Segment

- MOSFETs
 - Low Voltage TrenchFET® Power MOSFETs
 - Medium Voltage Power MOSFETs
 - High Voltage Planar MOSFETs
 - High Voltage Superjunction MOSFETs
 - Automotive Grade MOSFETs

- ICs
 - VRPower® DrMOS Integrated Power Stages
 - Power Management and Power Control ICs
 - Smart Load Switches
 - Analog Switches and Multiplexers

Diodes Segment

- Rectifiers
 - Schottky Rectifiers
 - Ultrafast Recovery Rectifiers
 - Standard and Fast Recovery Rectifiers
 - High Power Rectifiers / Diodes
 - Bridge Rectifiers

- Small Signal Diodes
 - Schottky and Switching Diodes
 - Zener Diodes
 - RF PIN Diodes

- Protection Diodes
 - TVS TRANSZORB® and PAR® Diodes (unidirectional, bidirectional)
 - ESD Protection Diodes (including arrays)

- Thyristors / SCRs
 - Phase Control Thyristors
 - Fast Thyristors

- Power Modules
 - Input Modules (diodes and thyristors)
 - Output and Switching Modules (contain MOSFETs, IGBTs, and diodes)
 - Custom Modules

Optoelectronic Components Segment

- Infrared Emitters and Detectors
- Large PIN Photo Diodes

- Optical Sensors
 - Proximity
 - Ambient Light
 - Gesture
 - Light Index (RGBW, UV, IR)
 - Humidity
 - Quadrant Sensors
 - Transmissive
 - Reflective

- Infrared Remote Control Receivers

- Optocouplers
 - Phototransistor, Photodarlington
 - Linear
 - Phototriac
 - High Speed
 - IGBT and MOSFET Drivers

- Solid-State Relays
- LEDs and 7-Segment Displays
- Infrared Data Transceiver Modules
- Custom Products



PASSIVE COMPONENTS

Resistors Segment

- Film Resistors - Chip, MELF, Leaded, and Networks
- Metal Film Resistors
- Thin Film Resistors
- Thick Film Resistors
- Power Thick Film Resistors
- Metal Oxide Film Resistors
- Carbon Film Resistors

- Wirewound Resistors
 - Vitreous, Cemented, and Housed Resistors
 - Braking and Neutral Grounding Resistors
 - Custom Load Banks

- Power Metal Strip® Resistors
- Battery Management Shunts
- Crowbar and Steel Blade Resistors
- High Power Water Cooled Resistors
- Thermo Fuses
- Chip Fuses

- Pyrotechnic Initiators / Igniters
- Variable Resistors
 - Cermet Variable Resistors
 - Wirewound Variable Resistors
 - Conductive Plastic Variable Resistors
 - Contactless Potentiometers
 - Hall Effect Position Sensors
 - Precision Magnetic Encoders

- Networks / Arrays / Attenuators
- RF and Microwave Resistors
- High Voltage Resistors
- Dividers

- Non-Linear Resistors and Temperature Sensors
 - NTC Thermistors
 - PTC Thermistors
 - Thin Film RTDs
 - Varistors
 - Platinum Chip Temperature Sensors

Inductors Segment

- Magnetics
 - Power Inductors Automotive and Commercial Grade
 - Coupled Inductors
 - Power Chokes
 - Common Mode Chokes
 - High Frequency RF Inductors
 - Magnetic Actuators
 - Wireless Charging Coils
 - Planar Devices
 - Transformers
 - Custom Magnetics

Connectors

Capacitors Segment

- Tantalum Capacitors
 - Molded Chip Tantalum Capacitors
 - Molded Chip Polymer Tantalum Capacitors
 - Tantalum MAP Capacitors
 - Polymer Tantalum MAP Capacitors
 - Coated Chip Tantalum Capacitors
 - Solid Through-Hole Tantalum Capacitors
 - Wet Tantalum Capacitors

- Ceramic Capacitors
 - Multilayer Chip Capacitors
 - Disc Capacitors
 - Multilayer Chip RF Capacitors
 - Chip Antennas
 - Thin Film Capacitors

- Film Capacitors
- Power Capacitors
- Heavy Current Capacitors
- Aluminum Electrolytic Capacitors
- ENYCAP™ Energy Storage Capacitors



© Copyright 2019 Vishay Intertechnology, Inc.
 ® Registered trademarks of Vishay Intertechnology, Inc.
 All rights reserved. Printed in Germany. Specifications subject to change without notice.