

	Date	11-Oct-2021	SPECIFICATION	OLE WOLFF
	Page	1 / 9		www.owolff.com
	DK	P/N: OWS-4065T-4C		Revision: 02



SPECIFICATION FOR APPROVAL

Speaker

Part Number	OWS-4065T-4C
Note	This item was compliance with the following requirements: 1. RoHS directive 2. REACH
Customer P/N	

Ole Wolff	Signature / Date	Prepared	Checked	Approved
		TANQIANFENG 2021.10.11		

Customer	Signature / Date	Confirmation		

REVISION NOTES:

Date	Rev.	Description of Revision
2019.07.03	00	Initial Release
2020.07.08	01	Change Test condition
2021.10.11	02	Update THD limit

OLE WOLFF ELEKTRONIK A/S Roedengvej 25 4180 Soroe Denmark TEL: +45 57833830 FAX: +45 57820019	OLE WOLFF ELECTRONICS INC. 1525 McCarthy Blvd, Suite 1093 Milpitas, Ca 95035 USA TEL: +1 408 888 8413	OLEWOLFF ELEKTRONIK GmbH Schulstrasse 15A. DE-25451 Quickborn. Germany TEL: +49 (0) 4106 765900 FAX: +49 (0) 4106 627297	OLEWOLFF ELECTRONICS 3 Bedford Street, Woburn, Bedfordshire MK17 9QB, ENGLAND TEL: +44 (0) 1525 290755 FAX: +44 (0) 1525 290855	OLE WOLFF ELEKTRONIK Yliopistonkatu 26 (P.O.BOX 257) FI-40101 Jyväskylä Finland TEL: +358 14 338 3050 FAX: +358 14 338 3059	OLE WOLFF (ASIA) LTD. Unit B, 19/F, Bold Win Ind. Bldg., No. 16-18 Wah Sing St., Kwai Chung, N.T., H.K. TEL: +852 2424 3274 FAX: +852 2424 2219	OLE WOLFF LTD. Unit 7A08, Block 2, Elite Building, Nanshan Avenue, Nanshan District, Shenzhen, PRC. TEL: +86 755 82612542 TEL: +86 755 26406156
---	---	--	---	--	---	---

	Date	11-Oct-2021	SPECIFICATION	OLE WOLFF
	Page	2 / 9		www.owolff.com
	DK	P/N: OWS-4065T-4C		Revision: 02

1. SCOPE

THIS SPECIFICATION IS APPLIED FOR A DYNAMIC SPEAKER.

2. TEST CONDITIONS

TEMPERATURE : 15°C ~ 35°C

HUMIDITY : 45%~85% (R.H.)

ATMOSPHERE : 860 ~ 1060 hPa

3. GENERAL REQUIREMENTS

OPERATING TEMPERATURE RANGE: -40° C ~ 85° C

STORAGE TEMPERATURE RANGE: -40° C ~ 85° C

4. MECHANICAL LAYOUT & DIMENSIONS

DIMENSIONS : SHOWN IN FIGURE.3

NET WEIGHT: approx 15.2g

5. ELECTRICAL AND ACOUSTICAL CHARACTERISTICS

1	Resonance Frequency	420± 20% Hz/1V
2	Impedance	4± 15%Ω 1KHz/1V
3	Sensitivity	118±3 dB(2.5W/20mm) AT AVG.(0.5,0.6,1.0,1.2)KHz
4	Input Power	(Nom./Max.): 2.5 W /3.0W
5	Effective Frequency Range	F0~10KHz
6	Total Harmonic Distortion (THD)	< 10% at 710→ 7.1KHz,2.5W
7	Buzz & Rattle	3.16V F0~10KHz
8	Magnet	NdFeB φ 13.5 x2.1t mm

OLE WOLFF ELEKTRONIK A/S Roedengvej 25 4180 Soroe Denmark TEL: +45 57833830 FAX: +45 57820019	OLE WOLFF ELECTRONICS INC. 1525 McCarthy Blvd, Suite 1093 Milpitas, Ca 95035 USA TEL: +1 408 888 8413	OLEWOLFF ELEKTRONIK GmbH Schulstrasse 15A. DE-25451 Quickborn. Germany TEL: +49 (0) 4106 765900 FAX: +49 (0) 4106 627297	OLEWOLFF ELECTRONICS 3 Bedford Street, Woburn, Bedfordshire MK17 9QB, ENGLAND TEL: +44 (0) 1525 290755 FAX: +44 (0) 1525 290855	OLE WOLFF ELEKTRONIK Yliopistonkatu 26 (P.O.BOX 257) FI-40101 Jyväskylä Finland TEL: +358 14 338 3050 FAX: +358 14 338 3059	OLE WOLFF (ASIA) LTD. Unit B, 19/F, Bold Win Ind. Bldg., No. 16-18 Wah Sing St., Kwai Chung, N.T., H.K. TEL: +852 2424 3274 FAX: +852 2424 2219	OLE WOLFF LTD. Unit 7A08, Block 2, Elite Building, Nanshan Avenue, Nanshan District, Shenzhen, PRC. TEL: +86 755 82612542 TEL: +86 755 26406156
---	---	--	---	--	---	---

	Date	11-Oct-2021	SPECIFICATION	OLE WOLFF
	Page	3 / 9		www.owolff.com
	DK	P/N: OWS-4065T-4C		Revision: 02

6. RELIABILITY TEST REQUIREMENTS.

After any following tests the S.P.L should not deviate more than ± 3 dB from initial value.		
No.	ITEMS	TEST CONDITION
1.	High Temp. Test	Keep 96 hours at $+85^{\circ}\text{C} \pm 3^{\circ}\text{C}$ and leave 3 hours in normal temperature and then check
2.	Low Temp. Test	Keep 96 hours at $-40^{\circ}\text{C} \pm 3^{\circ}\text{C}$ and leave 3 hours in normal temperature and then check
3.	Humidity Test	Keep 96 hours at $+40^{\circ}\text{C} \pm 3^{\circ}\text{C}$ relative humidity 95% and leave 3 hours in normal temperature and then check
4.	Thermal cycle Test	Low temperature: $-40 \pm 3^{\circ}\text{C}$, High temperature: $+85 \pm 3^{\circ}\text{C}$, cycle: 1 hour/cycle, total 5 cycles.
5.	Vibration Test	10~55~10Hz sin-wave sweep 15min. 5G(constant); X, Y, Z 3 direction, 2 hours each, total 6 hours.
6.	Drop Test	Free drop a unit from 100cm height to 20mm thick board. 6 directions, total 6 times.
7.	Load Test	Rated Power white noise is applied for 96 hours
8.	Max Power Test	Max Power 1min on, 2min off, 10cycles.
9.	Terminal strength Test	Capable of withstand 1kg load for 15seconds without resulting in any damage or rejection

OLE WOLFF ELEKTRONIK A/S Roedengvej 25 4180 Soroe Denmark TEL: +45 57833830 FAX: +45 57820019	OLE WOLFF ELECTRONICS INC. 1525 McCarthy Blvd, Suite 1093 Milpitas, Ca 95035 USA TEL: +1 408 888 8413	OLEWOLFF ELEKTRONIK GmbH Schulstrasse 15A. DE-25451 Quickborn. Germany TEL: +49 (0) 4106 765900 FAX: +49 (0) 4106 627297	OLEWOLFF ELECTRONICS 3 Bedford Street, Woburn, Bedfordshire MK17 9QB, ENGLAND TEL: +44 (0) 1525 290755 FAX: +44 (0) 1525 290855	OLE WOLFF ELEKTRONIK Yliopistonkatu 26 (P.O.BOX 257) FI-40101 Jyväskylä Finland TEL: +358 14 338 3050 FAX: +358 14 338 3059	OLE WOLFF (ASIA) LTD. Unit B, 19/F, Bold Win Ind. Bldg., No. 16-18 Wah Sing St., Kwai Chung, N.T., H.K. TEL: +852 2424 3274 FAX: +852 2424 2219	OLE WOLFF LTD. Unit 7A08, Block 2, Elite Building, Nanshan Avenue, Nanshan District, Shenzhen, PRC. TEL: +86 755 82612542 TEL: +86 755 26406156
---	---	--	---	--	---	---

	Date	11-Oct-2021	SPECIFICATION	OLE WOLFF
	Page	4 / 9		www.owolff.com
	DK	P/N: OWS-4065T-4C		Revision: 02

7. MEASUREMENT CIRCUIT (FIG.1)

MEASUREMENT CIRCUIT FOR DYNAMIC SPEAKER ↓

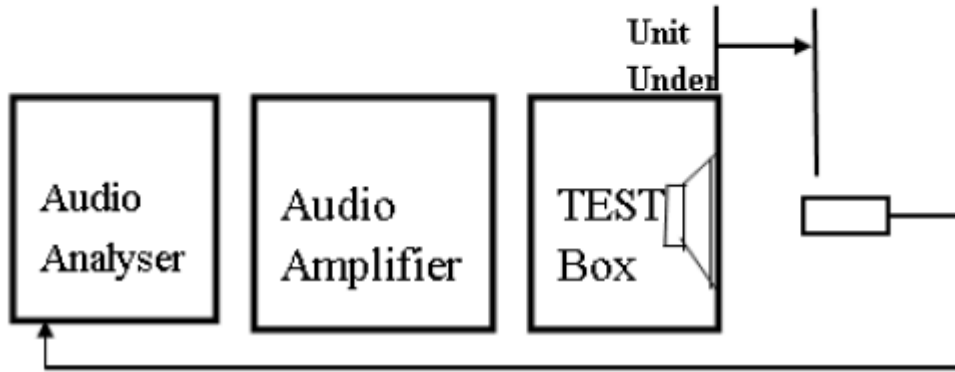

MEASURING EQUIPMENT ↓

NO. ↓	EQUIPMENT ↓	REMARKS ↓
1.0 ↓	UNIT UNDER TEST ↓	SPEAKER ↓
2.0 ↓	TEST BOX ↓	OLE WOLFF STANDARD BOX ↓
3.0 ↓	AUDIO POWER AMPLIFIER ↓	CRATE AUDIO SPA300 ↓
4.0 ↓	ANALYZER ↓	LISTEN SOUNDCHECK ↓

OLE WOLFF ELEKTRONIK A/S Roedengvej 25 4180 Soroe Denmark TEL: +45 57833830 FAX: +45 57820019	OLE WOLFF ELECTRONICS INC. 1525 McCarthy Blvd, Suite 1093 Milpitas, Ca 95035 USA TEL: +1 408 888 8413	OLEWOLFF ELEKTRONIK GmbH Schulstrasse 15A. DE-25451 Quickborn. Germany TEL: +49 (0) 4106 765900 FAX: +49 (0) 4106 627297	OLEWOLFF ELECTRONICS 3 Bedford Street, Woburn, Bedfordshire MK17 9QB, ENGLAND TEL: +44 (0) 1525 290755 FAX: +44 (0) 1525 290855	OLE WOLFF ELEKTRONIK Yliopistonkatu 26 (P.O.BOX 257) FI-40101 Jyväskylä Finland TEL: +358 14 338 3050 FAX: +358 14 338 3059	OLE WOLFF (ASIA) LTD. Unit B, 19/F, Bold Win Ind. Bldg., No. 16-18 Wah Sing St., Kwai Chung, N.T., H.K. TEL: +852 2424 3274 FAX: +852 2424 2219	OLE WOLFF LTD. Unit 7A08, Block 2, Elite Building, Nanshan Avenue, Nanshan District, Shenzhen, PRC. TEL: +86 755 82612542 TEL: +86 755 26406156
---	---	--	---	--	---	---

	Date	11-Oct-2021	SPECIFICATION	OLE WOLFF
	Page	5 / 9		www.owolff.com
	DK	P/N: OWS-4065T-4C		Revision: 02

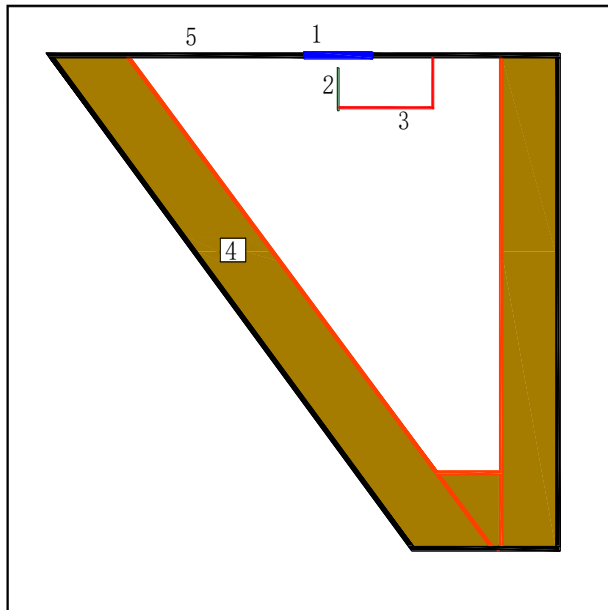

Dimension of test box
Length:97cm
Width:46cm
Height:68cm
Foam thickness:8cm
Wood wall are 1.8cm thickness.

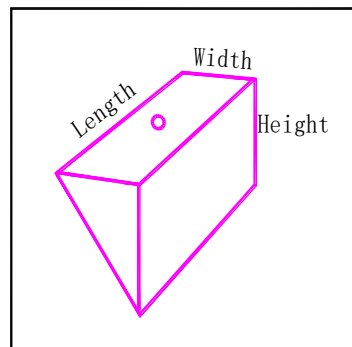

NO.	EQUIPMENT	REMARKS
1	TEST JIG	FIG. 1A
2	MICROPHONE	1/2 INCH MICROPHONE
3	MICROPHONE HOLDER	
4	DAMPING MATERIAL	FOAM RUBBER
5	BOX	WOOD
6	TEST DISTARCE MEASURED FROM FRONT OF SPEAKER FRAME TO FRONT OF TEST MICROPHONE	20mm

OLE WOLFF ELEKTRONIK A/S Roedengvej 25 4180 Soroe Denmark TEL: +45 57833830 FAX: +45 57820019	OLE WOLFF ELECTRONICS INC. 1525 McCarthy Blvd, Suite 1093 Milpitas, Ca 95035 USA TEL : +1 408 888 8413	OLEWOLFF ELEKTRONIK GmbH Schulstrasse 15A. DE-25451 Quickborn. Germany TEL: +49 (0) 4106 765900 FAX: +49 (0) 4106 627297	OLEWOLFF ELECTRONICS 3 Bedford Street, Woburn, Bedfordshire MK17 9QB, ENGLAND TEL: +44 (0) 1525 290755 FAX: +44 (0) 1525 290855	OLE WOLFF ELEKTRONIK Yliopistonkatu 26 (P.O.BOX 257) FI-40101 Jyväskylä Finland TEL: +358 14 338 3050 FAX: +358 14 338 3059	OLE WOLFF (ASIA) LTD. Unit B, 19/F, Bold Win Ind. Bldg., No. 16-18 Wah Sing St., Kwai Chung, N.T., H.K. TEL: +852 2424 3274 FAX: +852 2424 2219	OLE WOLFF LTD. Unit 7A08, Block 2, Elite Building, Nanshan Avenue, Nanshan District, Shenzhen, PRC. TEL: +86 755 82612542 TEL: +86 755 26406156
---	--	--	---	--	---	---

	Date	11-Oct-2021	SPECIFICATION	OLE WOLFF
	Page	6 / 9		www.owolff.com
	DK	P/N: OWS-4065T-4C		Revision: 02

8. STANDARD FREQUENCY RESPONSE CURVE(Fig.2)

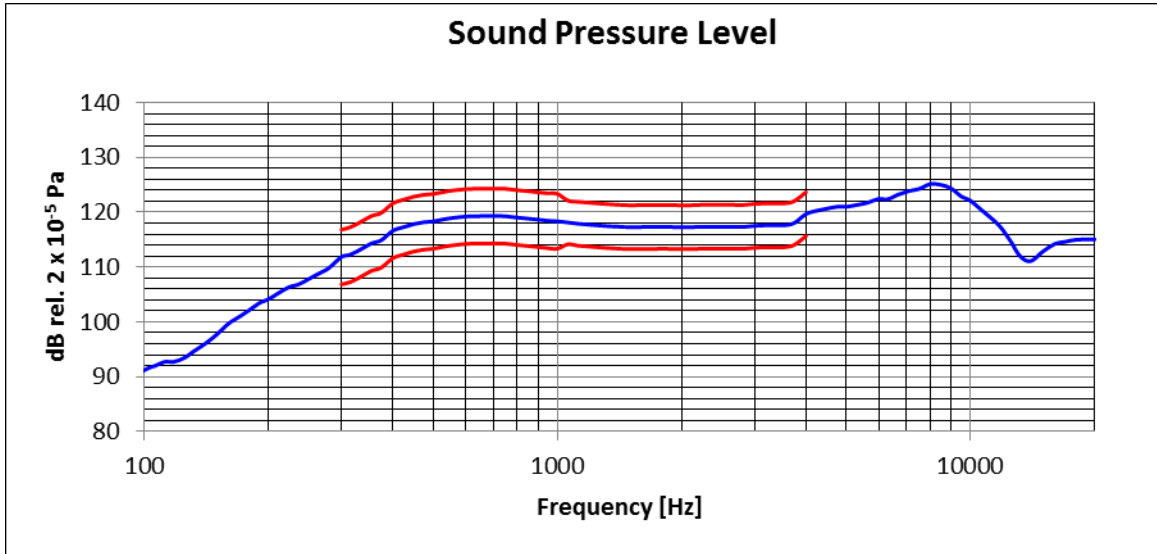

Hz	300~1000	1060~4000
dB	±5	±4

9. THD CURVE(Fig.3)

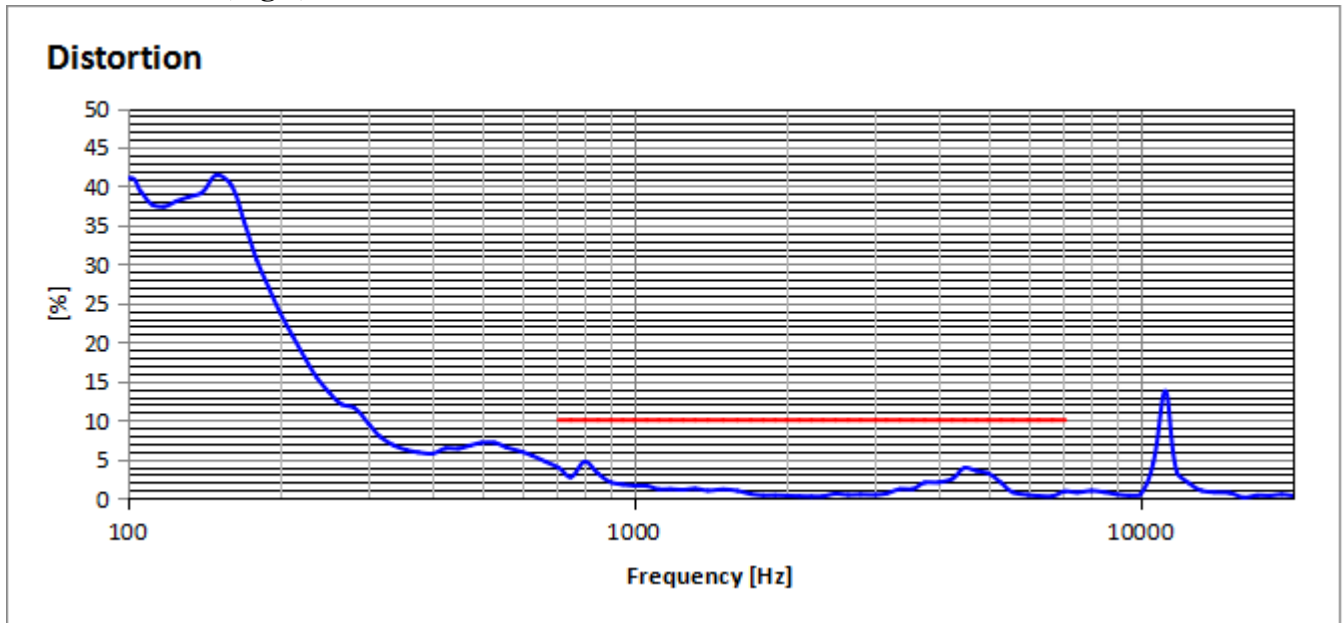

Hz	710~7100
THD	≤10%

OLE WOLFF ELEKTRONIK A/S Roedengvej 25 4180 Soroe Denmark TEL: +45 57833830 FAX: +45 57820019	OLE WOLFF ELECTRONICS INC. 1525 McCarthy Blvd, Suite 1093 Milpitas, Ca 95035 USA TEL: +1 408 888 8413	OLEWOLFF ELEKTRONIK GmbH Schulstrasse 15A, DE-25451 Quickborn, Germany TEL: +49 (0) 4106 765900 FAX: +49 (0) 4106 627297	OLEWOLFF ELECTRONICS 3 Bedford Street, Woburn, Bedfordshire MK17 9QB, ENGLAND TEL: +44 (0) 1525 290755 FAX: +44 (0) 1525 290855	OLE WOLFF ELEKTRONIK Yliopistonkatu 26 (P.O.BOX 257) FI-40101 Jyväskylä Finland TEL: +358 14 338 3050 FAX: +358 14 338 3059	OLE WOLFF (ASIA) LTD. Unit B, 19/F, Bold Win Ind. Bldg., No. 16-18 Wah Sing St., Kwai Chung, N.T., H.K. TEL: +852 2424 3274 FAX: +852 2424 2219	OLE WOLFF LTD. Unit 7A08, Block 2, Elite Building, Nanshan Avenue, Nanshan District, Shenzhen, PRC. TEL: +86 755 82612542 TEL: +86 755 26406156
---	---	--	---	--	---	---

	Date	11-Oct-2021	SPECIFICATION	OLE WOLFF
	Page	7 / 9		www.owolff.com
	DK	P/N: OWS-4065T-4C	Revision: 02	

10.OUTVIEW (Fig.4)

Unless otherwise specified,tolerance:±0.3(unit:mm)

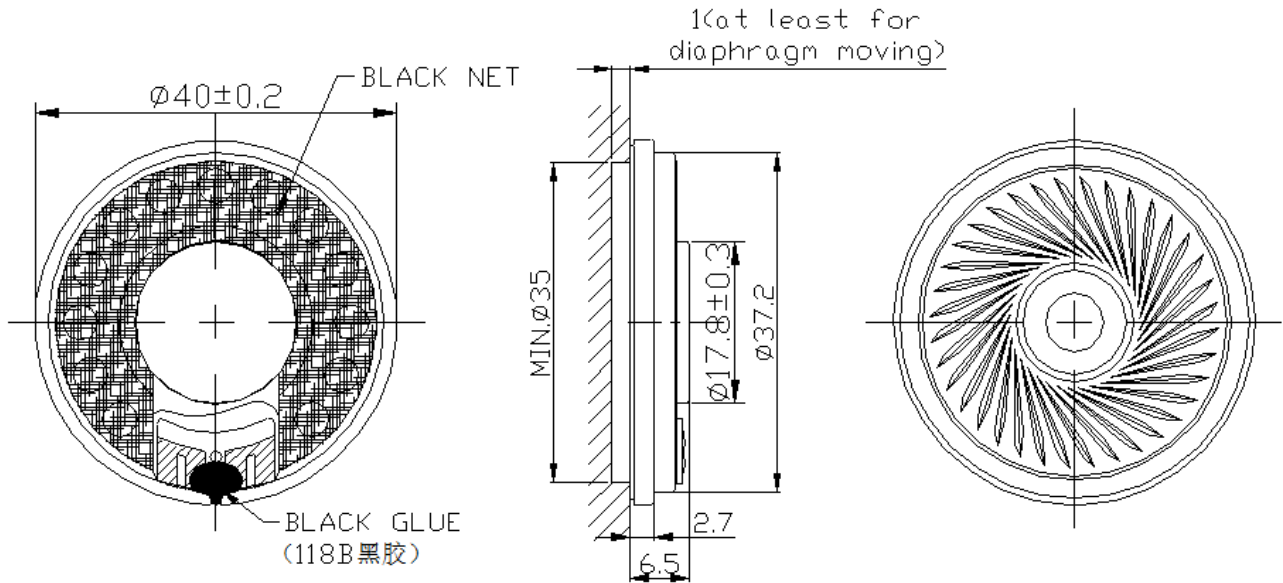

OLE WOLFF ELEKTRONIK A/S Roedengvej 25 4180 Soroe Denmark TEL: +45 57833830 FAX: +45 57820019	OLE WOLFF ELECTRONICS INC. 1525 McCarthy Blvd, Suite 1093 Milpitas, Ca 95035 USA TEL: +1 408 888 8413	OLEWOLFF ELEKTRONIK GmbH Schulstrasse 15A. DE-25451 Quickborn. Germany TEL: +49 (0) 4106 765900 FAX: +49 (0) 4106 627297	OLEWOLFF ELECTRONICS 3 Bedford Street, Woburn, Bedfordshire MK17 9QB, ENGLAND TEL: +44 (0) 1525 290755 FAX: +44 (0) 1525 290855	OLE WOLFF ELEKTRONIK Yliopistonkatu 26 (P.O.BOX 257) FI-40101 Jyväskylä Finland TEL: +358 14 338 3050 FAX: +358 14 338 3059	OLE WOLFF (ASIA) LTD. Unit B, 19/F, Bold Win Ind. Bldg., No. 16-18 Wah Sing St., Kwai Chung, N.T., H.K. TEL: +852 2424 3274 FAX: +852 2424 2219	OLE WOLFF LTD. Unit 7A08, Block 2, Elite Building, Nanshan Avenue, Nanshan District, Shenzhen, PRC. TEL: +86 755 82612542 TEL: +86 755 26406156
---	---	--	---	--	---	---

	Date	11-Oct-2021	SPECIFICATION	OLE WOLFF
	Page	8 / 9		www.owolff.com
	DK	P/N: OWS-4065T-4C		Revision: 02

11.MARKING (Fig.5)

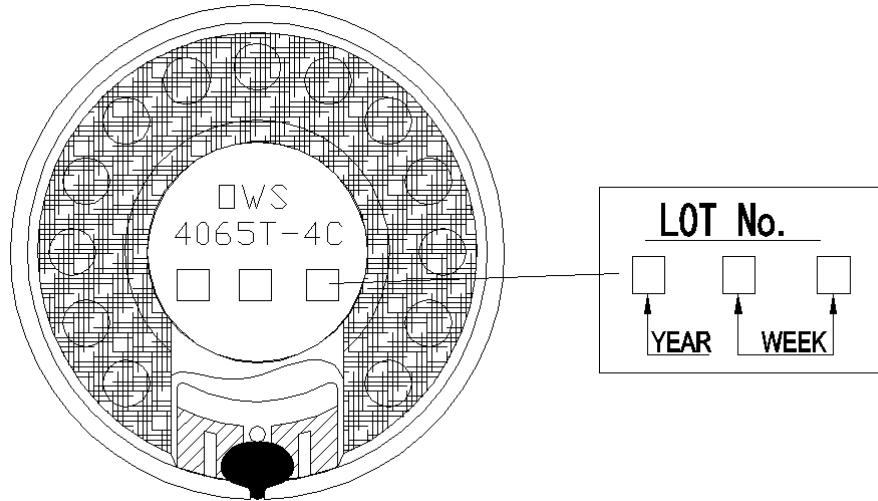

YEAR		WEEK	
year	marking	week	marking
2015	5	1	01
2016	6	2	02
2017	7	3	03
2018	8	4	04
2019	9	5	05
2020	0	↓	↓
2021	1		
2022	2		
		50	50
		51	51
		52	52
		53	53

OLE WOLFF ELEKTRONIK A/S Roedengvej 25 4180 Soroe Denmark TEL: +45 57833830 FAX: +45 57820019	OLE WOLFF ELECTRONICS INC. 1525 McCarthy Blvd, Suite 1093 Milpitas, Ca 95035 USA TEL: +1 408 888 8413	OLEWOLFF ELEKTRONIK GmbH Schulstrasse 15A, DE-25451 Quickborn, Germany TEL: +49 (0) 4106 765900 FAX: +49 (0) 4106 627297	OLEWOLFF ELECTRONICS 3 Bedford Street, Woburn, Bedfordshire MK17 9QB, ENGLAND TEL: +44 (0) 1525 290755 FAX: +44 (0) 1525 290855	OLE WOLFF ELEKTRONIK Yliopistonkatu 26 (P.O.BOX 257) FI-40101 Jyväskylä Finland TEL: +358 14 338 3050 FAX: +358 14 338 3059	OLE WOLFF (ASIA) LTD. Unit B, 19/F, Bold Win Ind. Bldg., No. 16-18 Wah Sing St., Kwai Chung, N.T., H.K. TEL: +852 2424 3274 FAX: +852 2424 2219	OLE WOLFF LTD. Unit 7A08, Block 2, Elite Building, Nanshan Avenue, Nanshan District, Shenzhen, PRC. TEL: +86 755 82612542 TEL: +86 755 26406156
---	---	--	---	--	---	---

	Date	11-Oct-2021	SPECIFICATION	OLE WOLFF
	Page	9 / 9		www.owolff.com
	DK	P/N: OWS-4065T-4C		Revision: 02

12. PACKING(Fig.6)

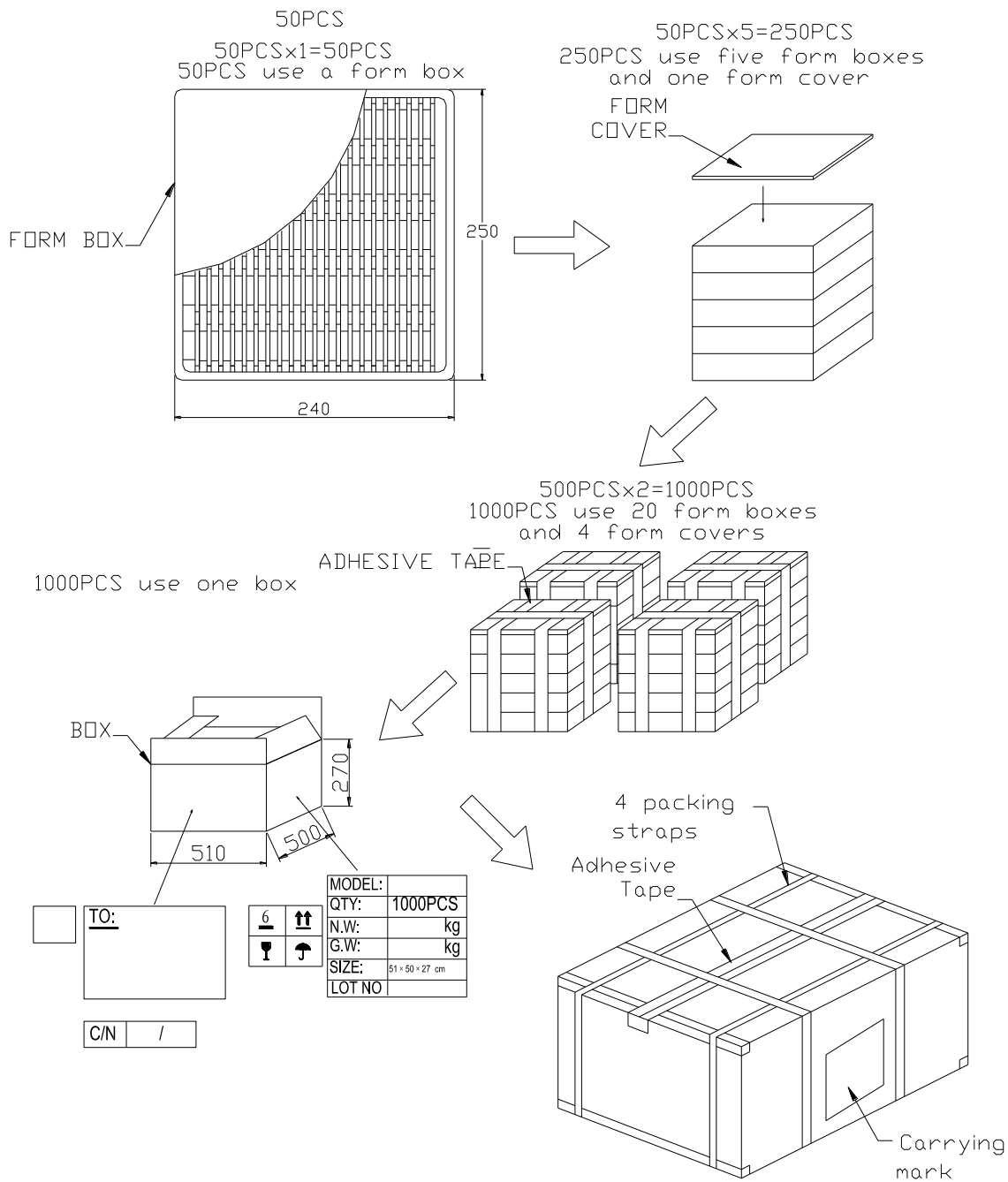

OLE WOLFF ELEKTRONIK A/S Roedengvej 25 4180 Soroe Denmark TEL: +45 57833830 FAX: +45 57820019	OLE WOLFF ELECTRONICS INC. 1525 McCarthy Blvd, Suite 1093 Milpitas, Ca 95035 USA TEL: +1 408 888 8413	OLEWOLFF ELEKTRONIK GmbH Schulstrasse 15A. DE-25451 Quickborn. Germany TEL: +49 (0) 4106 765900 FAX: +49 (0) 4106 627297	OLEWOLFF ELECTRONICS 3 Bedford Street, Woburn, Bedfordshire MK17 9QB, ENGLAND TEL: +44 (0) 1525 290755 FAX: +44 (0) 1525 290855	OLE WOLFF ELEKTRONIK Yliopistonkatu 26 (P.O.BOX 257) FI-40101 Jyväskylä Finland TEL: +358 14 338 3050 FAX: +358 14 338 3059	OLE WOLFF (ASIA) LTD. Unit B, 19/F, Bold Win Ind. Bldg., No. 16-18 Wah Sing St., Kwai Chung, N.T., H.K. TEL: +852 2424 3274 FAX: +852 2424 2219	OLE WOLFF LTD. Unit 7A08, Block 2, Elite Building, Nanshan Avenue, Nanshan District, Shenzhen, PRC. TEL: +86 755 82612542 TEL: +86 755 26406156
---	---	--	---	--	---	---