

**PROPRIETARY INFORMATION:**  
 PROPRIETARY OF GLOBTEK, INC. ANY REPRODUCTION, DISCLOSURE OR USE OF THIS DRAWING, IN WHOLE OR IN PART, IS HEREBY PROHIBITED EXCEPT AS SPECIFIED IN WRITING BY GLOBTEK, INC.

REVISION			
REV	DESCRIPTION	DATE	APPROVED
A	INITIAL RELEASE, RFS. 6844, DMR	08/11/05	DMR
B	ADD PACKING, RFS. 8833, SO	07/10/06	HM
C	DELETE 'CHINA', RFS. 15902, RN	03/26/09	HM
D	REVISE PACKAGING, RFS. 15936, MS	04/01/09	HM
E	REVISE DESCRIPTION, RFS. 18361, SO	03/30/10	HM

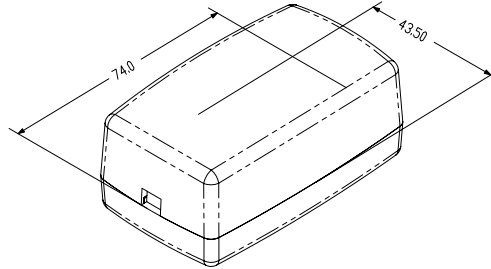

STANDARD OPTION SHIPS WITHOUT AC PINS INSTALLED

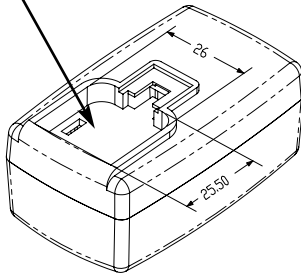

**1. MATERIAL**

HIGH IMPACT PLASTIC, 94V0 POLYCARBONATE, NON-VENTED, COLOR BLACK

**2. INPUT CONNECTOR:**

CLASS II MODEL NEMA 1-15P AC POWER RECEPTACLE WITH 2 PRONGS

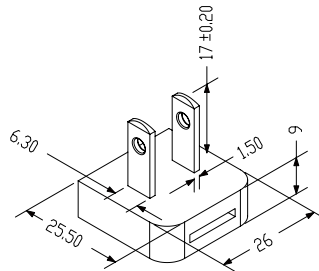

P/N: Q-NA(R)  
 NORTH AMERICA  
 JAPAN

**Foot Note:**  
 Globtek Inc. will not be liable for the safety and performance of these power supplies if unauthorized access and repair occurs. End user should consult applicable UL, CSA or EN standards for proper installation instructions

**Limitation of Use:**  
 Globtek product are not authorized for use as mission critical components in life support, hazardous environment, nuclear or aircraft applications without prior written approval from the CEO of Globtek Inc.

DASH NO.	PART NO	REV.	DESCRIPTION	NOTES
<b>TABULATION BLOCK</b>				
		<b>TOLERANCES:</b> DECIMALS ANGULAR .xx +/- 0.1 +/- 1° .xxx +/- .005		<b>GlobTek, Inc.</b> www.globtek.com 186 Veterans Dr. Northvale, NJ 07647 Tel. 201-784-1000 Fax 201.784.0111
		<b>MILLIMETERS ANGULAR</b> .xx +/- 0.3 +/- 1° .xxx +/- .013		
INIT.BY: DMR	DATE: 08/11/05	DWG TITLE: NORTH AMERICA INTERCHANGEABLE INPUT BLADES		
DRAWN: NF	DATE: 08/11/05	FSCN No.: G, N	SIZE A	MODEL NO: N/A
APRVD : DMR	DATE: 08/11/05	SCALE: NONE	PART NO: Q-NA(R)	REV. E
				SHEET 1 OF 2

**PROPRIETARY INFORMATION:**

PROPRIETARY OF GLOBTEK, INC. ANY REPRODUCTION, DISCLOSURE OR USE OF THIS DRAWING, IN WHOLE OR IN PART, IS HEREBY PROHIBITED EXCEPT AS SPECIFIED IN WRITING BY GLOBTEK, INC.

**3. PACKING:**

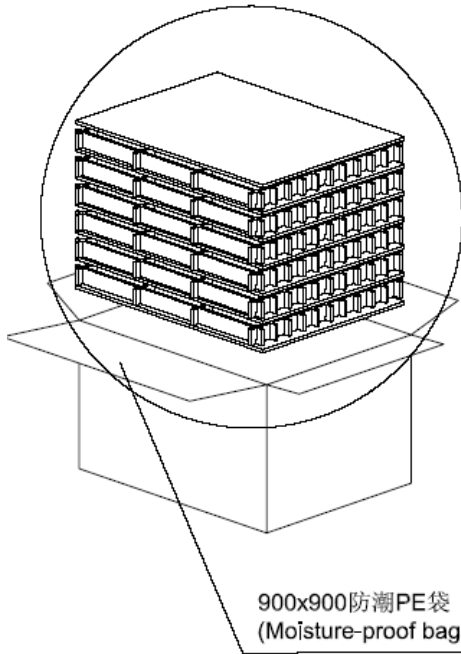

900 PCS/CARTON  
(150PCS\*6)

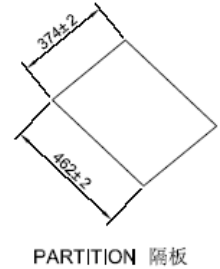
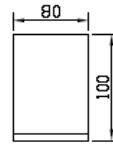
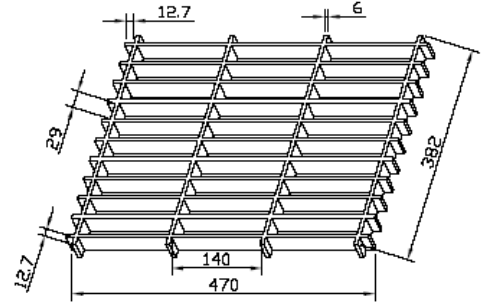
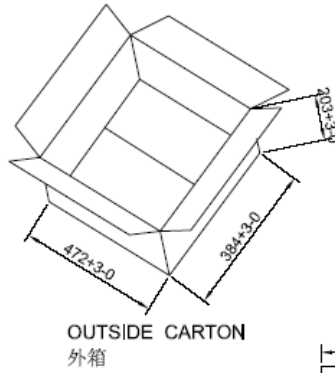

**GlobTek, Inc.**  
www.globtek.com

186 Veterans Dr. Northvale, NJ 07647  
Tel. 201-784-1000 Fax 201.784.0111

DWG TITLE: NORTH AMERICA INTERERCHANGEABLE INPUT BLADES

MODEL NO: N/A

REV.  
E

PART NO: Q-NA(R)

SHEET 2 OF 2