

**RECOMMENDED  
CABLE STRIPPING DIMENSIONS**  
SWITCHCRAFT STRIPPING TOOL #PTS1

**ALTERNATE KNURL DESIGN**

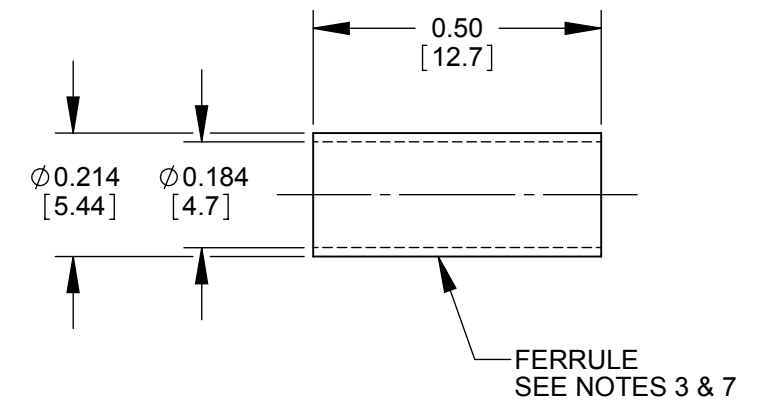
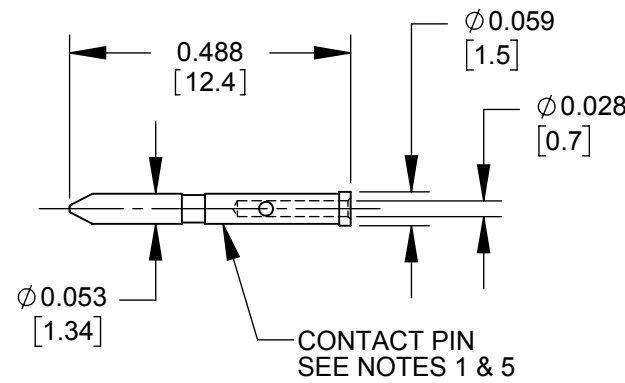
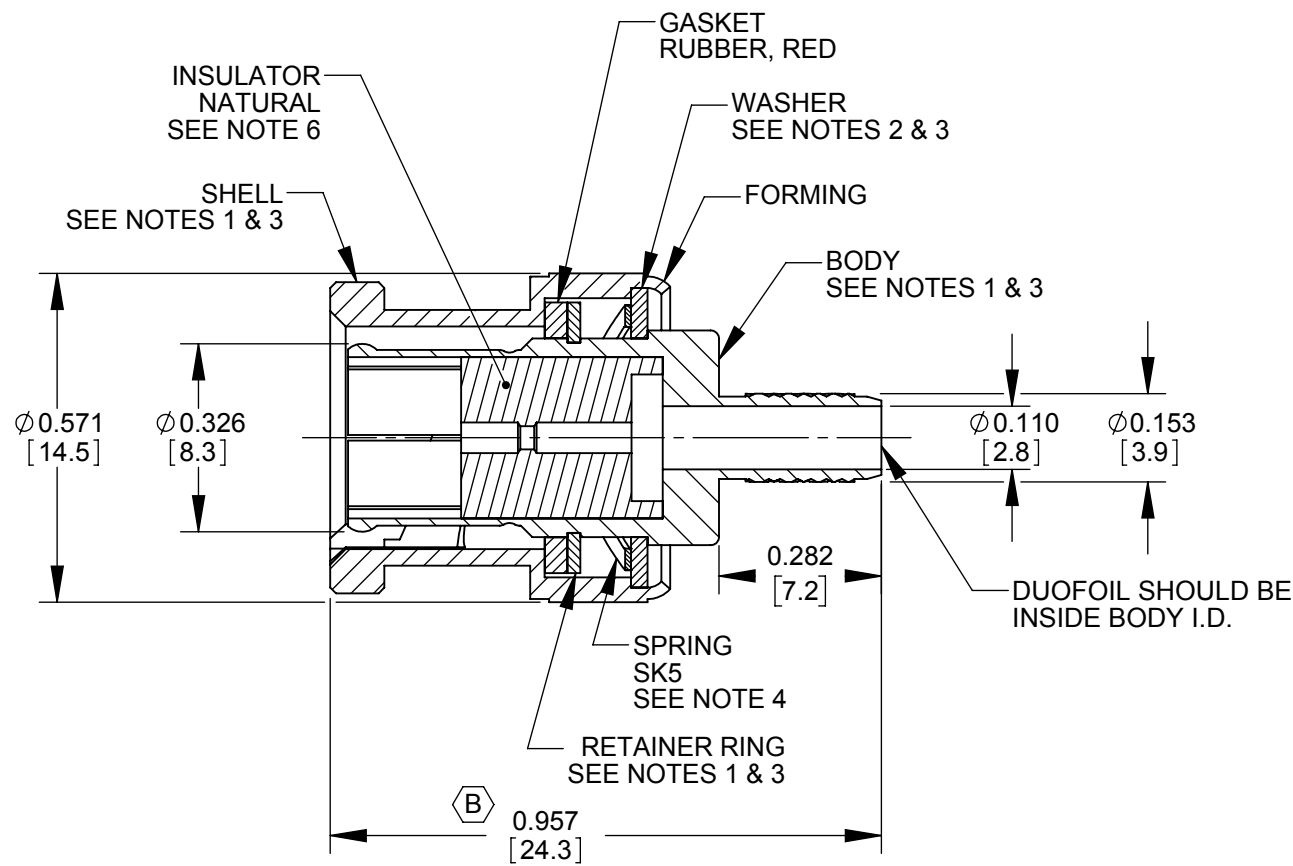

**SECTION A-A**

**NOTES:**

**FINISH (PLATING THICKNESS IN MICRO-INCHES)**

1. BRASS PER QQ-B-626
2. BRASS PER QQ-B-613
3. NICKEL PLATING 100 MIN THICK OVER COPPER STRIKE.
4. NICKEL PLATING 200 MIN THICK OVER COPPER STRIKE.
5. GOLD PLATING 50 MIN THICK OVER NICKEL PLATING 100 MIN THICK OVER COPPER STRIKE.
6. TEFLON MIL-P-19468
7. JIS H 3250, C2600
8. CRIMPED FERRULE HEX CRIMP SIZE 0.178.
9. CRIMPED CONTACT PIN SQUARE CRIMP SIZE 0.042 OR HEX CRIMP SIZE 0.041.
10. ALL DIMENSIONS ARE REFERENCE.
11. THIS PRODUCT MEETS SMPTE ST 2082-1.
12. THIS PRODUCT IS RoHS COMPLIANT.

**CUSTOMER DRAWING**

| REV       | ECO NUMBER | DATE     | BY | APVD |
|-----------|------------|----------|----|------|
| B         | 28086      | 10-26-18 | PC | TJK  |
| A         | 27942      | 11-28-17 | PC | TJK  |
| REVISIONS |            |          |    |      |

|                                      |  |  |  |  |
|--------------------------------------|--|--|--|--|
| UNLESS OTHERWISE SPECIFIED           |  |  |  |  |
| 1. ALL DIMENSIONS IN INCHES [mm]     |  |  |  |  |
| - TWO PLACE DECIMALS ±0.02 [0.5]     |  |  |  |  |
| - THREE PLACE DECIMALS ±0.005 [0.13] |  |  |  |  |
| DO NOT SCALE DRAWING                 |  |  |  |  |

|  |       |      |           |        |                                 |  |       |  |  |
|--|-------|------|-----------|--------|---------------------------------|--|-------|--|--|
| THIS DRAWING DESCRIBES A DESIGN CONSIDERED PROPRIETARY IN NATURE, DEVELOPED AND MANUFACTURED BY SWITCHCRAFT INC. AND IS RELEASED ON A CONFIDENTIAL BASIS FOR IDENTIFICATION PURPOSES ONLY. |       |      |           |        |                                 |  |       |  |  |
| SIZE   | WIDTH | MULT | LBS/M     | TEMPER |                                 |  |       |  |  |
| FINISH SPEC No.  |       |      |           |        | MATERIAL SPEC No.               |  |       |  |  |
| FIRST USED ON  |       |      | SCALE 3:1 |        | <b>Switchcraft</b> <sup>®</sup> |  |       |  |  |
| DATE DRAWN   | BY    | CHKD | APVD      |        |                                 |  |       |  |  |
| 10-17-16   | SRC   | SRC  | TJK       |        | SHEET 1 OF 1                    |  |       |  |  |
| NAME UHD BNC CONNECTOR 4855R CABLE, RoHS   |       |      |           |        | PART No. UHDBNC55               |  | REV B |  |  |