

REVISION RECORD				
REV	ECO	DESCRIPTION	DRFT	CHKD
△		ADD PART NUMBER	YAN 05/30/05	
△		ADD PART NUMBER	ANKUE 11/17/05	
△		MODIFY NOTES	ANKUE 06/29/06	

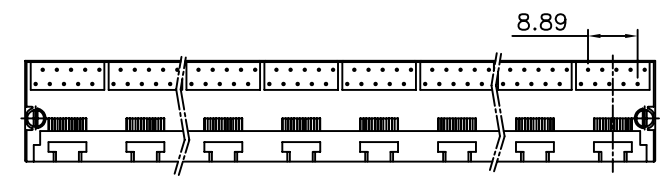

(MAXTOP TYPE)  
△ Scale: 2:5

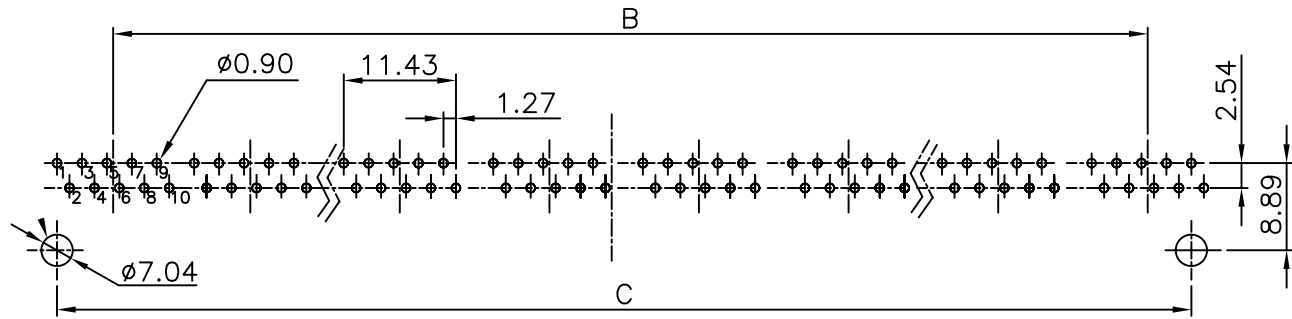
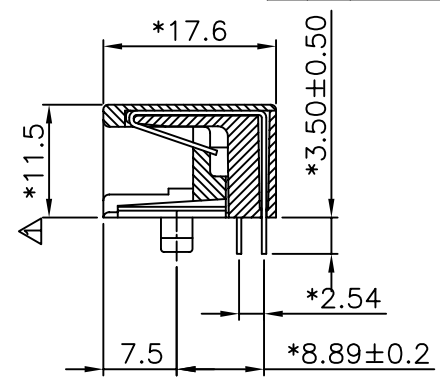
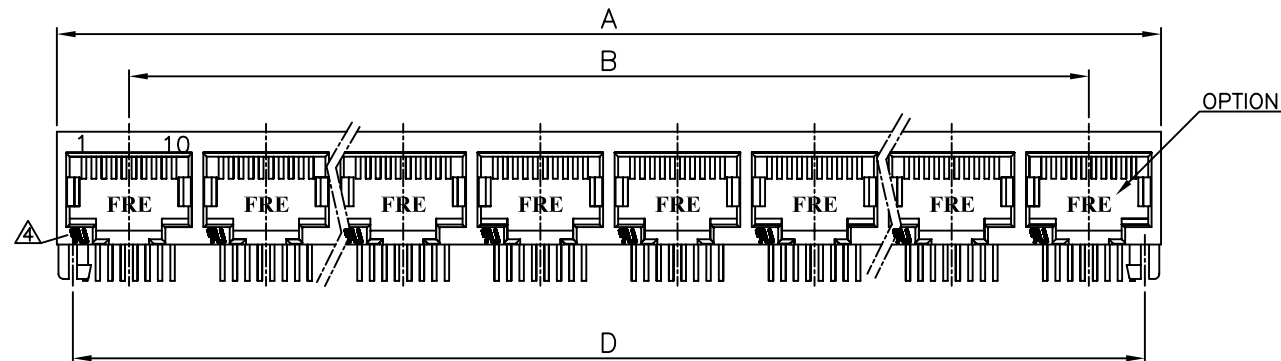
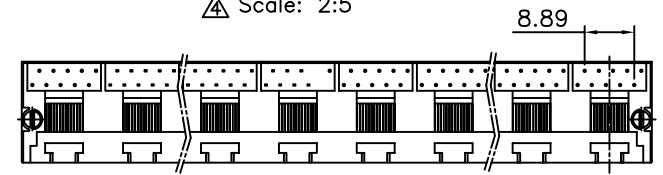

(FRE TYPE)  
△ Scale: 2:5

PC Board Layout Component Side Shown

PORTS	DIM "A" ±0.10	DIM "B" ±0.20	DIM "C" ±0.15	DIM "D" ±0.15
2	30.48	13.97	25.40	25.40
6	86.36	86.36	81.28	81.28
8	114.30	97.79	109.22	109.22

NOTES:

ELECTRICAL:

- VOLTAGE RATING : 125 VAC RMS.
- CURRENT RATING : 1.5 AMP
- CONTACT RESISTANCE : 45 MILLIOHMS MAX.
- INSULATION RESISTANCE : 1000 MEGOHMS MIN @ 500 VDC.
- DIELECTRIC STRENGTH : 1000 VAC RMS 60HZ,1MIN.

MECHANICAL:

- HOUSING MATERIAL : NYLON+GF30% UL94V-0. COLOR:BLACK.
- CONTACT MATERIAL : PHOSPHOR BRONZE Ø0.46mm..
- PLATING : GOLD PLATING OVER NICKEL.
- OPERATING LIFE : 750 CYCLES MIN.
- PCB RETENTION PRE-SOLDER : 1 LB MIN.
- PCB RETENTION POST-SOLDER : 10 LBS MIN.

ENVIRONMENTAL:

- STORAGE : -40°C TO +85°C.
  - OPERATION : -40°C TO +85°C.
  - WAVE SOLDER TEMPERATURE: 255°C TO 265°C 5~10 SECONDS.
  - RoHS COMPLIANT.
- MATES WITH MODULAR PLUG CONFORMING TO FCC PART 68, SUBPART F.  
CUL FILE NO. E163191

△RoHS PART NUMBER: E560X-X0XXXX-L △

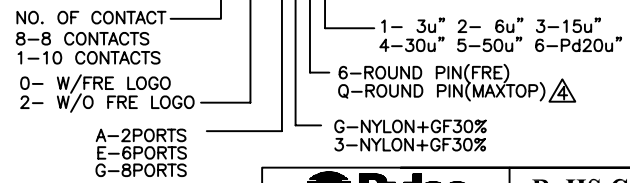

DETACHED LISTS	MM (INCH)	DFTO SHINE	DATE 3/31/01
	TOLERANCES EXCEPT AS NOTED	CHKD ASHELLY	DATE 2006/7/10
	MM	MFO	DATE
	.0 ± 0.2 ±	APPVL LUSHENG	DATE 2006/7/10
	.00 ± 0.15 ±	MATERIAL :	
.000 ± 0.075 ±	ANGLES ± 0.5	QT'Y :	
	THIRD ANGLE PROJECTION	FINISH :	
		SCALE : 4:5	

	RoHS Compliant
FULL RISE ELECTRONIC CO., LTD	
TITLE 11.5 SIDE ENTRY PCB GANG JACK 10P	
DRAWING NO. GE563062-LA	SIZE A3
/PART NO. SEE NOTE	REV 4
DO NOT SCALE DRAWING	SHEET 1 OF 1