

# (5V/3.3V) V23826-K15-C(\*)

## Single Mode 1300 nm 1.0625 Gb/s Fibre Channel 1.3 Gigabit Ethernet 1x9 Transceiver

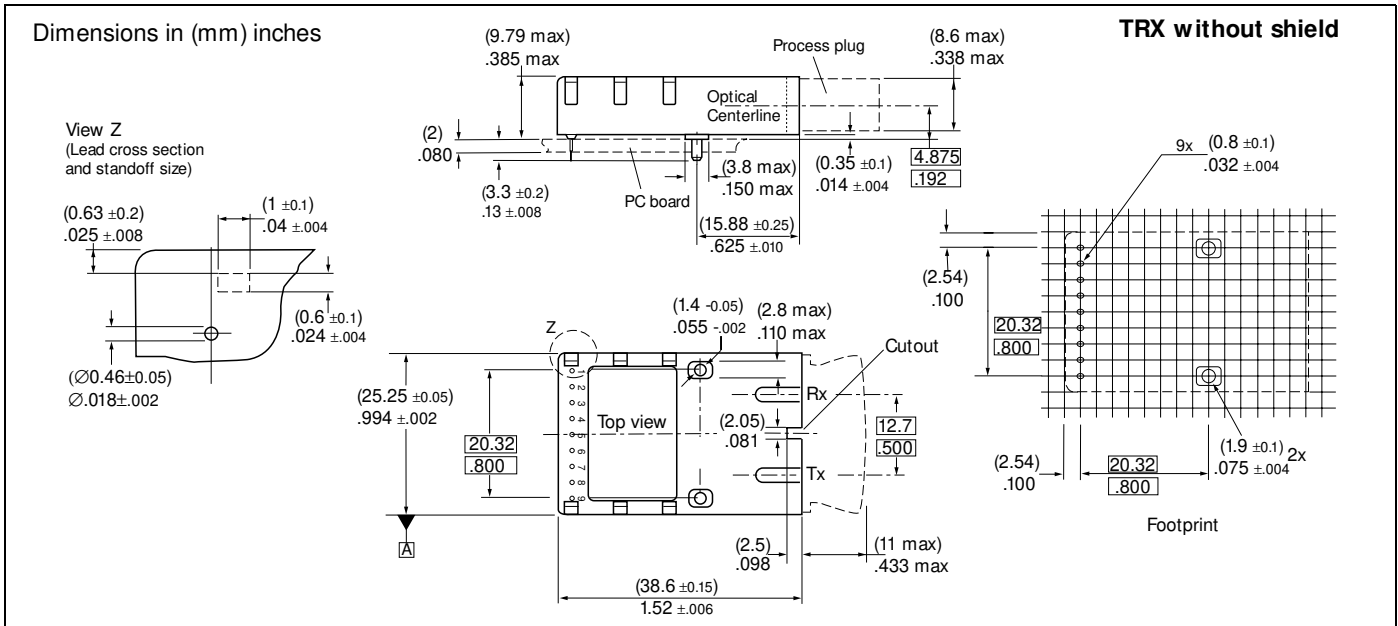

### FEATURES

- Compliant with Fibre Channel and Gigabit Ethernet standard
- Meets mezzanine standard height of 9.8 mm
- Compact integrated transceiver unit with
  - MQW laser diode transmitter
  - InGaAs PIN photodiode receiver
  - Duplex SC receptacle
- Class 1 FDA and IEC laser safety compliant
- Single power supply (5 V or 3.3 V)
- Signal detect indicator (PECL and TTL version)
- PECL differential inputs and outputs
- Process plug included
- Input Signal Monitor (DC/DC-Version)
- Performance exceeds FC 100-SM-LL-I
- Wave solderable and washable with process plug inserted
- For distances of up to 10 km on single mode fiber, and up to 550 m on multimode fiber (use offset jumper as specified in IEEE 802.3)

### Absolute Maximum Ratings

Exceeding any one of these values may destroy the device immediately.

Package Power Dissipation <sup>(1)</sup> .....	1.5 W
Supply Voltage ( $V_{CC}-V_{EE}$ ) 5 V .....	6 V
3.3 V .....	4 V
Data Input Levels (PECL) .....	$V_{CC}+0.5$ V
Differential Data Input Voltage .....	2.5 V
Operating Ambient Temperature .....	0° to 70°C
Storage Ambient Temperature .....	-40°C to 85°C
Soldering Conditions Temp/Time (MIL-STD 883C, Method 2003) .....	250°C/5.5s

### Note

1. For  $V_{CC}-V_{EE}$  (min., max.) 50% duty cycle. The supply current does not include the load drive current of the receiver output.

### \*) Ordering Information

Input	Output	Signal detect	Voltage	Part number
AC	DC	PECL	5 V	V23826-K15-C13
			3.3 V	V23826-K15-C313
AC	AC	TTL	5 V	V23826-K15-C53
			3.3 V	V23826-K15-C353
DC	DC	PECL	5 V	V23826-K15-C63 <sup>(1)</sup>
			3.3 V	V23826-K15-C363 <sup>(1)</sup>
AC	AC	PECL	5 V	V23826-K15-C73
			3.3 V	V23826-K15-C373
<b>Shield options</b>				<b>Add suffix to PIN</b>
Metallized cover, forward springs				-C3
Metallized cover, backward springs				-D3

### Note

1. Standard version

## DESCRIPTION

The Infineon single mode transceiver is based on the Physical Medium Depend (PMD) sublayer and baseband medium, type 100BASE-LX (Long Wavelength Laser) (IEEE 802.5) and complies with the Fibre Channel Physical and Signaling Interface (FC-PH), ANSI X3I TT Fibre Channel Physical Standard Class 100-SM-LL-I, latest Revision.

The appropriate fiber optic cable is 9  $\mu\text{m}$  (mode field diameter) single mode fiber (up to 10 km) with Duplex SC connector.

The Infineon single mode transceiver is a single unit comprised of a transmitter, a receiver, and an SC receptacle. This design frees the customer from many alignment and PC board layout concerns. The module is designed for low cost LAN, WAN and Gigabit Ethernet applications. It can be used as the network end device interface in mainframes, workstations, servers, and storage devices, and in a broad range of network devices such as bridges, routers, intelligent hubs, and local and wide area switches.

This transceiver operates at 1.0625 and 1.3 Gbit/s from a single power supply (+5 Volt or 3.3 Volt). The full differential data inputs and outputs are PECL compatible.

## Functional Description

This transceiver is designed to transmit serial data via single mode or multimode cable.

## Functional Diagram

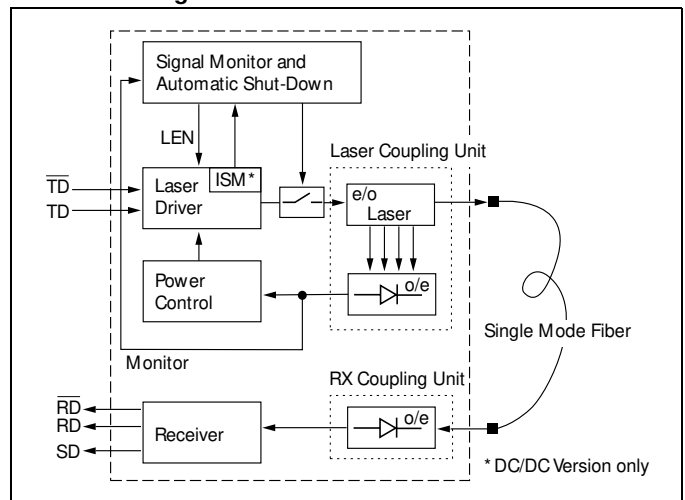

The receiver component converts the optical serial data into PECL compatible electrical data (RD and RDnot). The Signal Detect (SD, active high) shows whether an optical signal is present.

The transmitter converts electrical PECL compatible serial data (TD and TDnot) into optical serial data.

The following versions are available:

### 1. AC/DC Transceiver

Tx is AC coupled. Differential 100  $\Omega$  load. Rx has standard PECL output and is DC coupled.

### 2. AC/AC TTL Transceiver

Tx and Rx are AC coupled. Tx has differential 100  $\Omega$  load. Signal Detect is TTL compatible.

### 3. DC/DC Transceiver

Standard PECL inputs and outputs Tx and Rx are DC coupled. This version contains an Input Signal Monitor (ISM) which switches off the transceiver if a continuous low level is applied at Data Input.

### 4. AC/AC PECL Transceiver

Tx and Rx are AC coupled. Tx has differential 100  $\Omega$  load. Signal Detect is PECL compatible.

The transmitter contains a laser driver circuit that drives the modulation and bias current of the laser diode. The currents are controlled by a power control circuit to guarantee constant output power of the laser over temperature and aging.

The power control uses the output of the monitor PIN diode (mechanically built into the laser coupling unit) as a controlling signal, to prevent the laser power from exceeding the operating limits.

Single fault condition is ensured by means of an integrated automatic shutdown circuit that disables the laser when it detects transmitter failures. A reset is only possible by turning the power off, and then on again.

The transceiver contains a supervisory circuit to control the power supply. This circuit generates an internal reset signal whenever the supply voltage drops below the reset threshold. It keeps the reset signal active for at least 140 milliseconds after the voltage has risen above the reset threshold. During this time the laser is inactive.

## TECHNICAL DATA

The electro-optical characteristics described in the following tables are only valid for use under the recommended operating conditions.

### Recommended Operating Conditions

Parameter	Symbol	Min.	Typ.	Max.	Units	
Ambient Temperature	T <sub>AMB</sub>	0		70	°C	
Power Supply Voltage	3.3 V	V <sub>CC-V<sub>EE</sub></sub>	3.1	3.3	3.5	V
	5 V		4.75	5	5.25	
Supply Current <sup>(1)</sup>	3.3 V	I <sub>CC</sub>		230	mA	
	5 V			270		
<b>Transmitter</b>						
Data Input High Voltage DC/DC	V <sub>IH-V<sub>CC</sub></sub>	-1165		-880	mV	
Data Input Low Voltage DC/DC	V <sub>IL-V<sub>CC</sub></sub>	-1810		-1475		
Data Input Differential Voltage <sup>(2)</sup> AC/DC, AC/AC TTL, AC/AC PECL	V <sub>DIFF</sub>	300		800		
Input Data Rise/Fall Time 10%–90%	t <sub>R</sub> , t <sub>F</sub>	100		750	ps	
<b>Receiver</b>						
Input Center Wavelength	λ <sub>C</sub>	1270		1355	nm	

#### Notes

- For V<sub>CC-V<sub>EE</sub></sub> (min., max.) 50% duty cycle. The supply current does not include the load drive current of the receiver output.
- Peak to peak voltage of one input.

### Transmitter Electro-Optical Characteristics

Transmitter	Symbol	Min.	Typ.	Max.	Units
Launched Power (Average) <sup>(1)</sup>	P <sub>O</sub>	-11.0		-3	dBm
Center Wavelength	λ <sub>C</sub>	1270		1355	nm
Spectral Width (RMS)	σ <sub>λ</sub>			4	
Relative Intensity Noise	RIN			-120	dB/Hz
Extinction Ratio (Dynamic)	ER	9			dB
Reset Threshold <sup>(2)</sup>	5 V	V <sub>TH</sub>	3.5		V
	3.3 V		2.7		
Reset Time Out <sup>(2)</sup>	t <sub>RES</sub>	15	22	35	ms

#### Notes

- Into single mode fiber, 9 μm diameter.
- Laser power is shut down if power supply is below V<sub>TH</sub> and switched on if power supply is above V<sub>TH</sub> after t<sub>RES</sub>.

### Receiver Electro-Optical Characteristics

Receiver	Symbol	Min.	Typ.	Max.	Units
Sensitivity (Average Power) <sup>(1)</sup>	P <sub>IN</sub>		-22	-20	dBm
Saturation (Average Power)	P <sub>SAT</sub>			-3	
Signal Detect Assert Level <sup>(2)</sup>	P <sub>SDA</sub>			-20	
Signal Detect Deassert Level <sup>(3)</sup>	P <sub>SDD</sub>	-30			dB
Signal Detect Hysteresis	P <sub>SDA-</sub> P <sub>SDD</sub>		1.5		
Signal Detect Assert Time	t <sub>ASS</sub>			100	μs
Signal Detect Deassert Time	t <sub>DAS</sub>			350	
Output Low Voltage <sup>(4)</sup>	V <sub>OL-V<sub>CC</sub></sub>	-1950		-1600	mV
Output High Voltage <sup>(4)</sup>	V <sub>OH-V<sub>CC</sub></sub>	-1025		-720	
Signal Detect Output Voltage AC/AC TTL <sup>(5)</sup>	Low	V <sub>SDL</sub>		0.5	V
	High	V <sub>SDH</sub>	2		
Data Output Differential Voltage <sup>(6)</sup>	V <sub>DIFF</sub>	0.5		0.9	
Output Data Rise/Fall Time, 20%–80%	t <sub>R</sub> , t <sub>F</sub>			375	ps
Return Loss of Receiver	A <sub>RL</sub>	12			dB

#### Notes

- Minimum average optical power at which the BER is less than 1×10<sup>-12</sup> or lower. Measured with a 2<sup>7</sup>-1 NRZ PRBS and ER=9 dB. Output of single mode fiber 9 μm diameter.
- An increase in optical power above the specified level will cause the SIGNAL DETECT output to switch from a Low state to a High state.
- A decrease in optical power below the specified level will cause the SIGNAL DETECT to change from a High state to a Low state.
- DC/DC, AC/DC for data  
DC/DC, AC/DC, AC/AC PECL for Signal Detect  
PECL compatible. Load is 50 Ω into V<sub>CC</sub> -2 V for data, 500 Ω to V<sub>EE</sub> for Signal Detect. Measured under DC conditions. For dynamic measurements a tolerance of 50 mV should be added. V<sub>CC</sub>=3.3 V/5 V. T<sub>AMB</sub>=25°C.
- Max. output current high: -0.4 mA (drive current)  
low: +2.0 mA (sink current)
- AC/AC for data. Load 50 Ω to GND or 100 Ω differential. For dynamic measurement a tolerance of 50mV should be added.

## Pin Description

Pin Name	Level/Logic	Pin#	Description	
RxV <sub>EE</sub>	Rx Ground	Power Supply	1	Negative power supply, normally ground
RD	Rx Output Data	PECL Output	2	Receiver output data
RD <sub>n</sub>			3	Inverted receiver output data
SD	Rx Signal Detect	PECL Output active high (TTL C53/353)	4	High level on this output shows there is an optical signal.
Rx-V <sub>CC</sub>	Rx 3.3V/5V	Power Supply	5	Positive power supply, 3.3V/5V
TxV <sub>CC</sub>	Tx 3.3V/5V		6	
TD <sub>n</sub>	Tx Input Data	PECL Input	7	Inverted transmitter input data
TD			8	Transmitter input data
TxV <sub>EE</sub>	Tx Ground	Power Supply	9	Negative power supply, normally ground
Case	Support	Mech. Support	S1/2	Not connected

## Regulatory Compliance

Feature	Standard	Comments
Electrostatic Discharge (ESD) to the Electrical Pins	MIL-STD 883C Method 3015.4	Class 1 (> 1000 V)
Immunity: Electrostatic Discharge (ESD) to the Duplex SC Receptacle	EN 61000-4-2 IEC 61000-4-2	Discharges of ± 15kV with an air discharge probe on the receptacle cause no damage.
Immunity: Radio Frequency Electromagnetic Field	EN 61000-4-3 IEC 61000-4-3	With a field strength of 10 V/m rms, noise frequency ranges from 10 MHz to 1 GHz. No effect on transceiver performance between the specification limits.
Emission: Electromagnetic Interference EMI	FCC Class B EN 55022 Class B CISPR 22	Noise frequency range: 30 MHz to 6 GHz; Margins depend on PCB layout and chassis design

## EYE SAFETY

This laser based single mode transceiver is a Class 1 product. It complies with IEC 60825-1 and FDA 21 CFR 1040.10 and 1040.11.

To meet laser safety requirements the transceiver shall be operated within the Absolute Maximum Ratings.

### Caution

**All adjustments have been made at the factory prior to shipment of the devices. No maintenance or alteration to the device is required. Tampering with or modifying the performance of the device will result in voided product warranty.**

### Note

Failure to adhere to the above restrictions could result in a modification that is considered an act of "manufacturing," and will require, under law, recertification of the modified product with the U.S. Food and Drug Administration (ref. 21 CFR 1040.10 (i)).

## Laser Data

Wavelength	1300 nm
Total output power (as defined by IEC: 50 mm aperture at 10 cm distance)	less than 2 mW
Total output power (as defined by FDA: 7 mm aperture at 20 cm distance)	less than 180 µW
Beam divergence	4°

## Required Labels

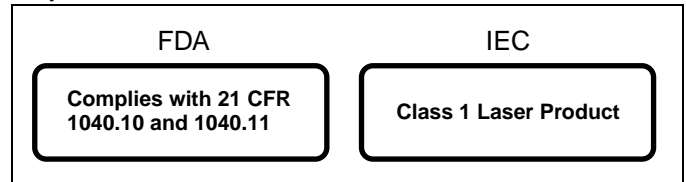

## Laser Emission

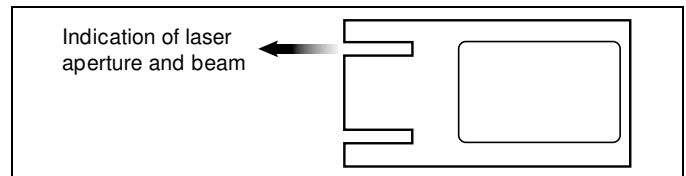

## APPLICATION NOTE

Gigabit transceivers and matching circuits are high frequency components and shall be terminated as recommended in the application notes for proper EMI performance. Electromagnetic emission may be caused by these components.

To prevent emissions it is recommended that cutouts for the fiber connectors be designed as small as possible.

It is strongly recommended that the Tx plug and the Rx plug be separated with a bar that divides the duplex SC opening.

If shielded parts are employed, they should be in proper contact with the bezel (back plane).

Since the shield is galvanically isolated from signal ground it is strongly recommended to prevent any contact between shield and the circuitry i.e. even any ground connection on the pcb may be harmful to EMI performance.

In cases where EMI performance becomes critical it has proven to be helpful when using SC-plugs with less metal parts inside (as Infineon fibers).

## APPLICATION NOTE

### Single Mode 1300 nm Gigabit Ethernet/Fibre Channel 1x9 Transceiver, DC/DC Version

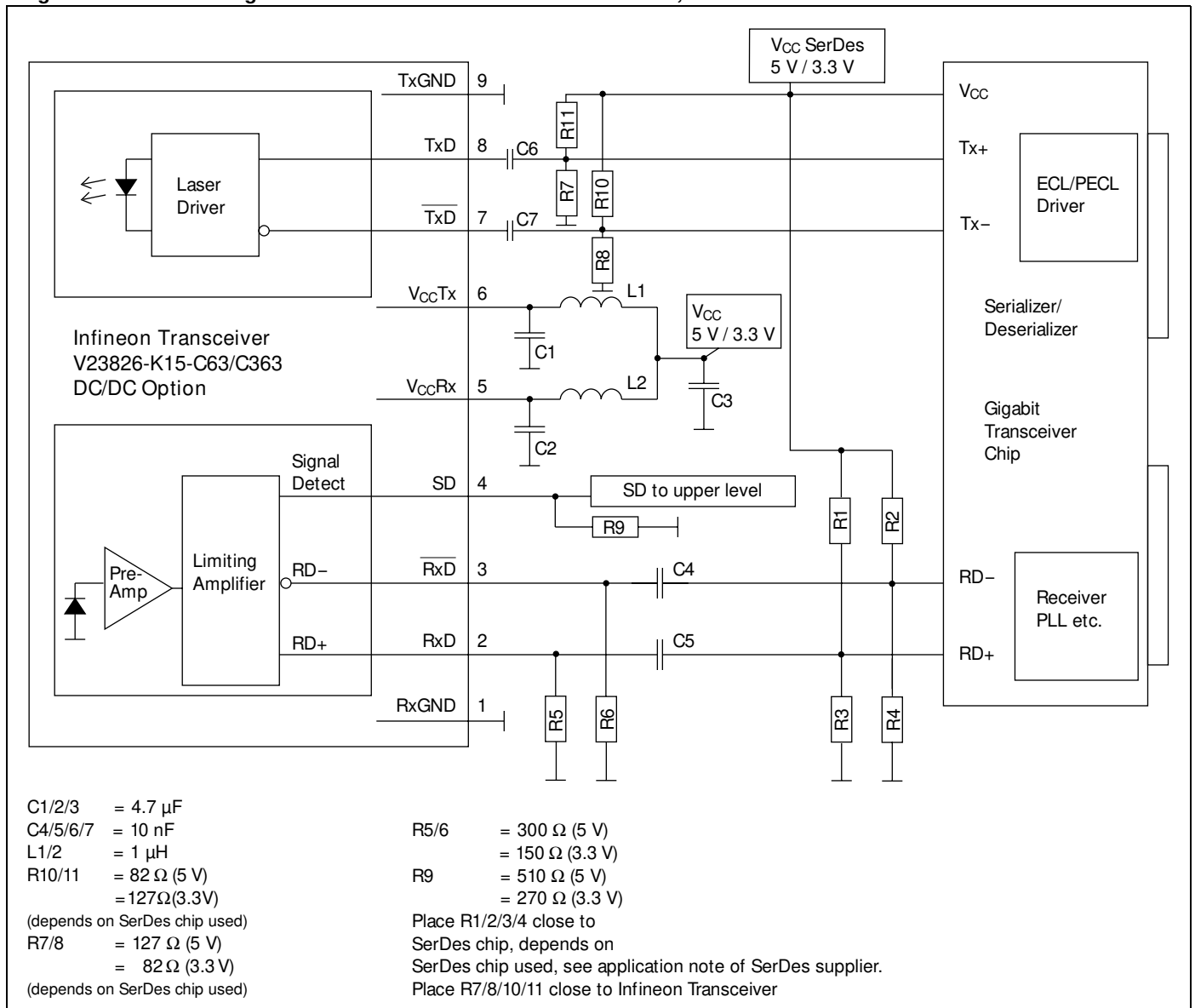

Values of R1/2/3/4 may vary as long as proper 50  $\Omega$  termination to  $V_{EE}$  or 100  $\Omega$  differential is provided. The power supply filtering is required for good EMI performance. Use short tracks from the inductor L1/L2 to the module  $V_{CCRX}/V_{CCTX}$ . We recommend a GND plane under the module for getting good EMI performance.

The transceiver contains an automatic shutdown circuit. Reset is only possible if the power is turned off, and then on again. ( $V_{CCTX}$  switched below  $V_{TH}$ ).

Application Board available on request.

**The stud pins S1 and S2 are not connected.**

**APPLICATION NOTE**

**Single Mode 1300nm Gigabit Ethernet/Fibre Channel 1x9 Transceiver, AC/DC Version**

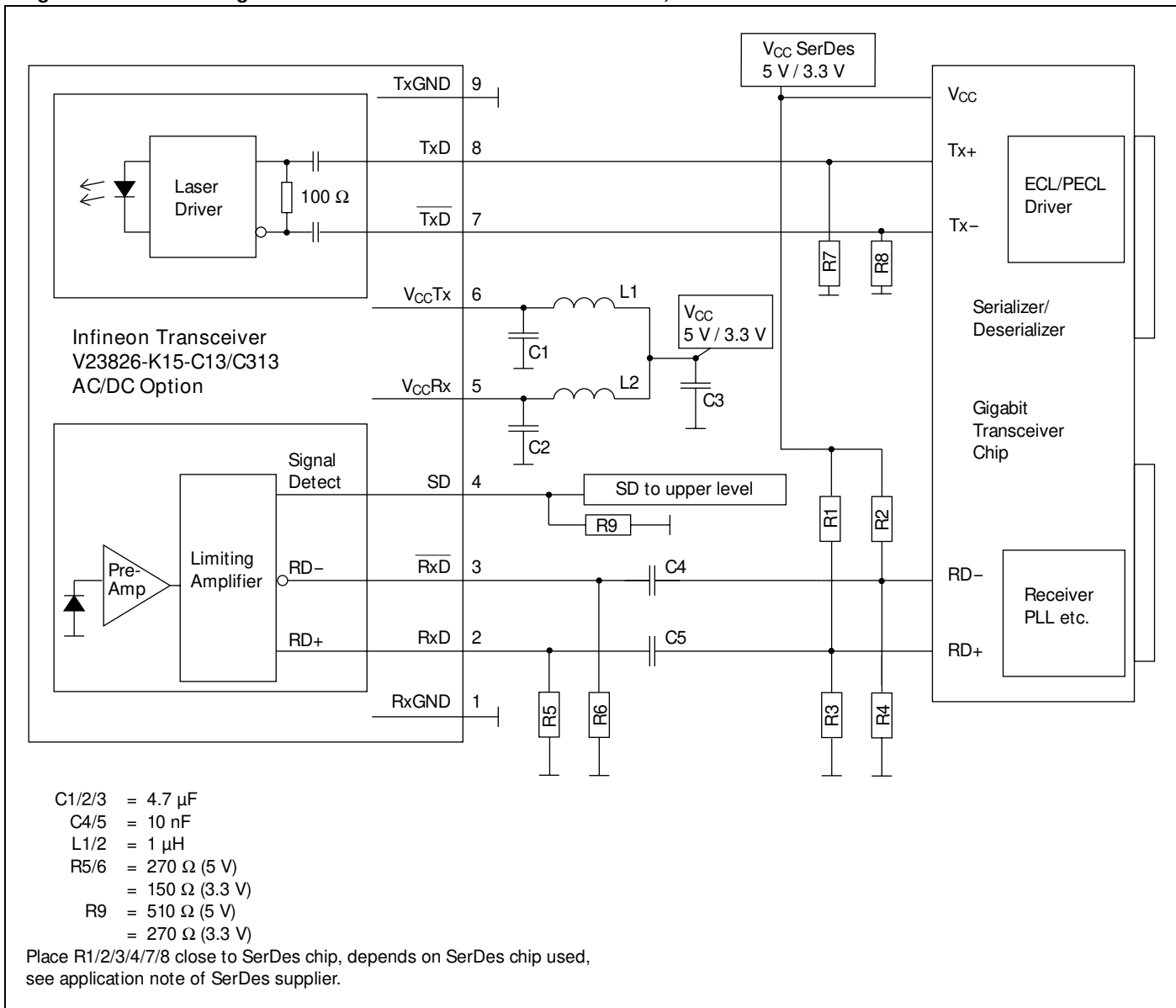

## APPLICATION NOTE

### Single Mode 1300nm Gigabit Ethernet/Fibre Channel 1x9 Transceiver, AC/AC TTL and AC/AC PECL Versions

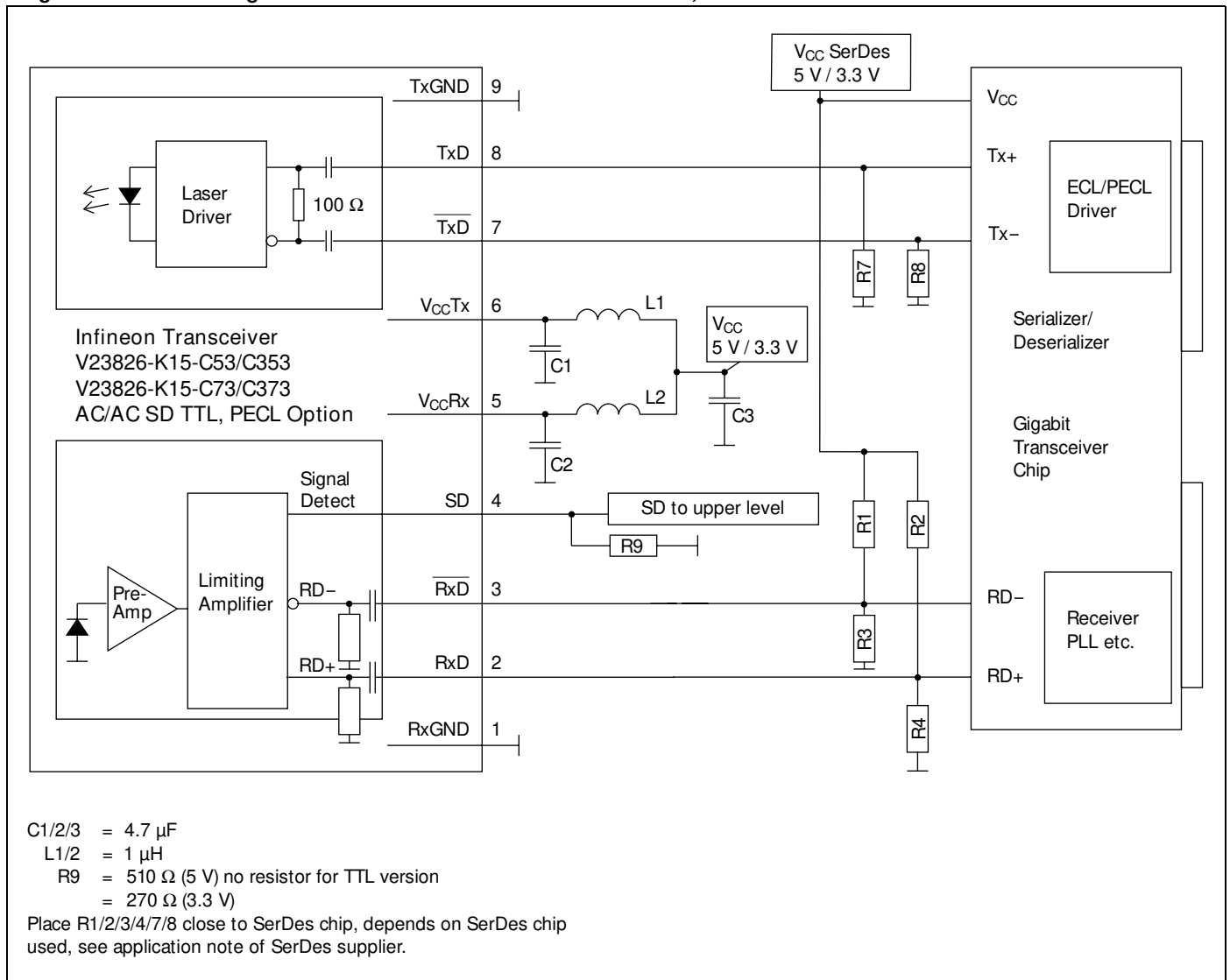

The power supply filtering is required for good EMI performance. Use short tracks from the inductor L1/L2 to the module  $V_{CCRx}/V_{CCTx}$ . We recommend a GND plane under the module for getting good EMI performance.

The transceiver contains an automatic shutdown circuit. Reset is only possible if the power is turned off, and then on again. ( $V_{CCTx}$  switched below  $V_{TH}$ ).

Application Board available on request.

**The stud pins S1 and S2 are not connected.**

**SHIELD OPTION**

**Shield with forward springs, -C3**

Dimensions in mm [inches]

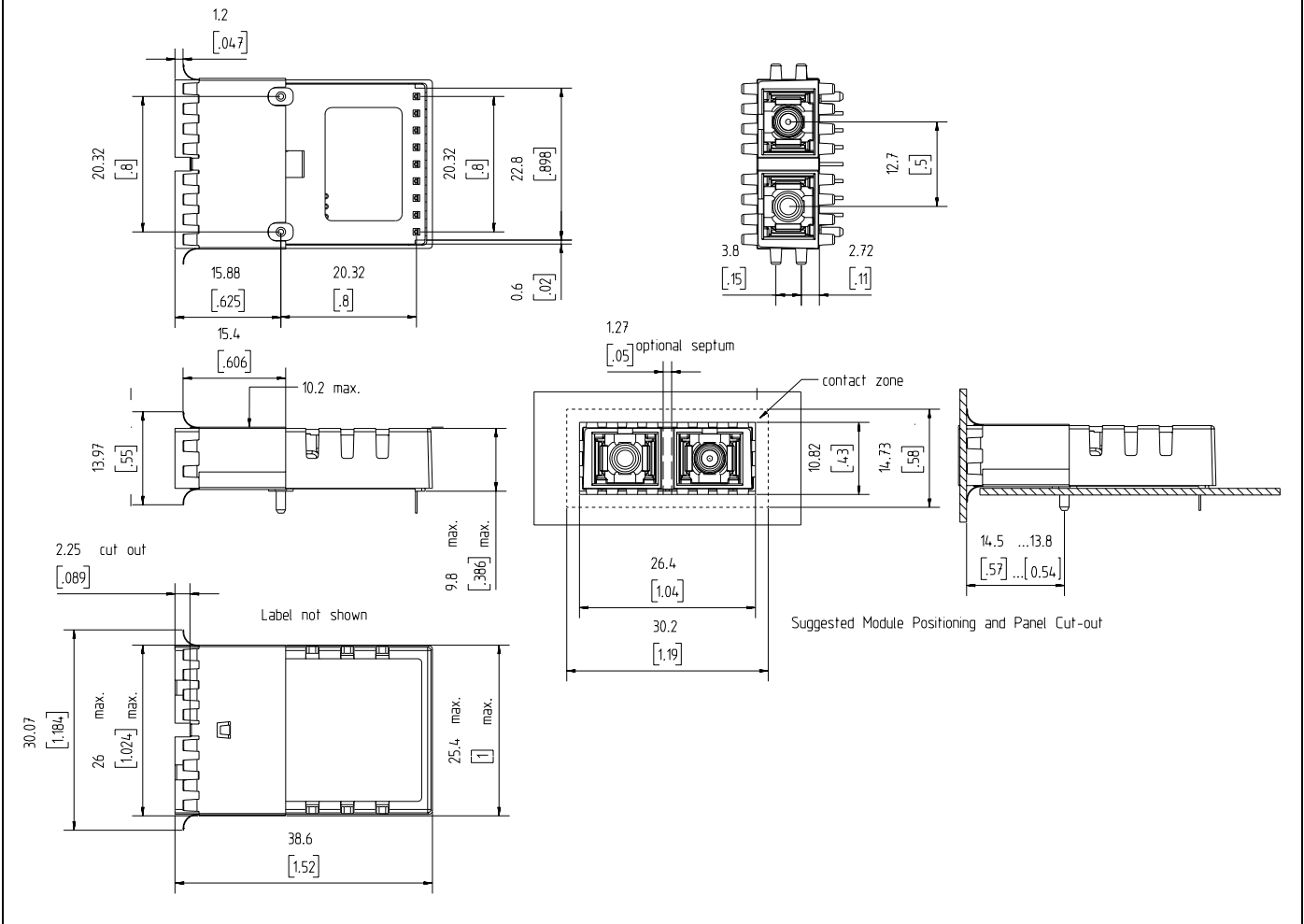



## SHIELD OPTION

### Shield with backward springs, -D3

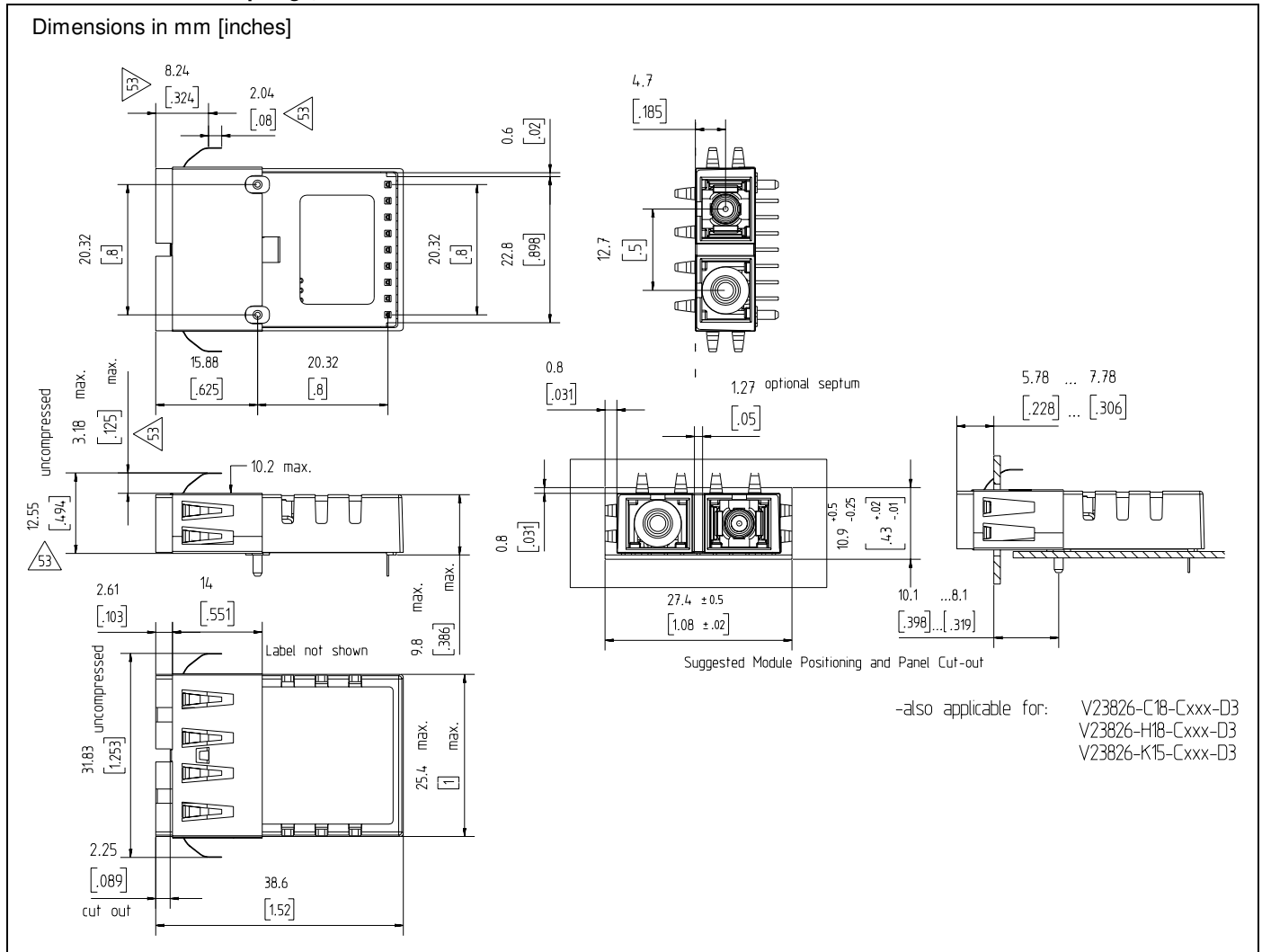

Published by Infineon Technologies AG

© Infineon Technologies AG 1999  
All Rights Reserved

#### Attention please!

The information herein is given to describe certain components and shall not be considered as warranted characteristics.  
Terms of delivery and rights to technical change reserved.  
We hereby disclaim any and all warranties, including but not limited to warranties of non-infringement, regarding circuits, descriptions and charts stated herein.  
Infineon Technologies is an approved CECC manufacturer.

#### Information

For further information on technology, delivery terms and conditions and prices please contact the Infineon Technologies offices or our Infineon Technologies Representatives worldwide - see our webpage at [www.infineon.com/fiberoptics](http://www.infineon.com/fiberoptics)

#### Warnings

Due to technical requirements components may contain dangerous substances. For information on the types in question please contact your Infineon Technologies offices.

Infineon Technologies Components may only be used in life-support devices or systems with the express written approval of Infineon Technologies, if a failure of such components can reasonably be expected to cause the failure of that life-support device or system, or to affect the safety or effectiveness of that device or system. Life support devices or systems are intended to be implanted in the human body, or to support and/or maintain and sustain and/or protect human life. If they fail, it is reasonable to assume that the health of the user or other persons may be endangered.