

4

3

2

1

THIS DRAWING IS UNPUBLISHED.

RELEASED FOR PUBLICATION

ALL RIGHTS RESERVED.

© COPYRIGHT - By -

REVISIONS

P	LTR	DESCRIPTION	DATE	DWN	APVD
1		NEW DRAWING	24JAN2017	BDA	MZ
A		REVISED PER ECO-19-003208	05MAR2019	RS	MZ

- 1 PARTS PACKAGED UNASSEMBLED.
- 2 CABLE CLAMPING AREA ADJUSTABLE FROM .100 TO .410 SQ IN BY REVERSING CLAMPING INSERTS. (2 INSERTS SUPPLIED)
- 3 .703 MAXIMUM CABLE OUTSIDE DIAMETER.
- 4 HOUSINGS MADE FROM MATERIAL RATED F1 FOR OUTDOOR SUITABILITY PER UL 746C.

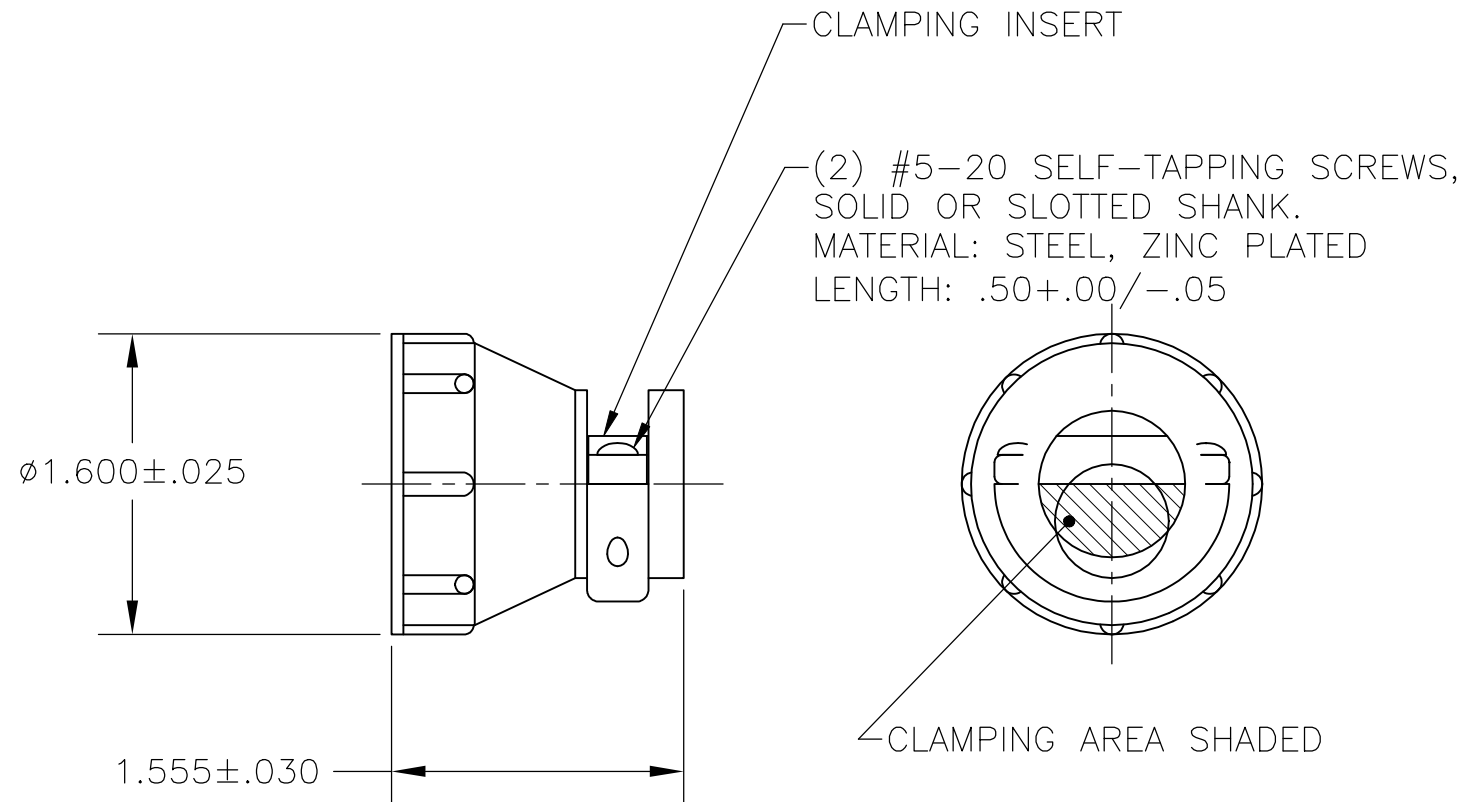

INDIVIDUAL	2267395-1
PACKAGING	PART NUMBER

THIS DRAWING IS A CONTROLLED DOCUMENT.		DWN	24JAN2017	TE Connectivity	
		CHK	24JAN2017		
		APVD	24JAN2017		
		PRODUCT SPEC			
DIMENSIONS: INCHES		TOLERANCES UNLESS OTHERWISE SPECIFIED:		NAME	
		0 PLC	± -	CPC SHELL SIZE 23 STANDARD CABLE CLAMP KIT, UV RESISTANT	
		1 PLC	± -		
		2 PLC	± -		
		3 PLC	± -		
MATERIAL		FINISH		APPLICATION SPEC	RESTRICTED TO
THERMOPLASTIC		-		108-10024	-
				WEIGHT	-
				CUSTOMER DRAWING	SCALE NTS SHEET 1 OF 1 REV A