



Part Number: D3C1530

Electrical Specifications

Frequency Range (GHz):	1.5 – 3.0
Isolation (dB):	16 MIN
Insertion Loss (dB):	0.7 MAX
VSWR:	1.4:1 MIN
Forward Power (W):	30 AVG 40 PK

Mechanical/Environmental Specifications

Connector Type:	SMA
Connector Body:	Passivated stainless steel
Connector Pin:	Gold plated copper
Load Body:	Brass
Magnetic Shunt:	Nickel plated CRS
Operational Temp:	0°C to +70°C
Weight (oz)	6.0 MAX

D3C1530 Dimensions

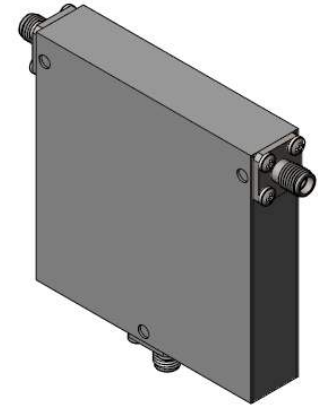
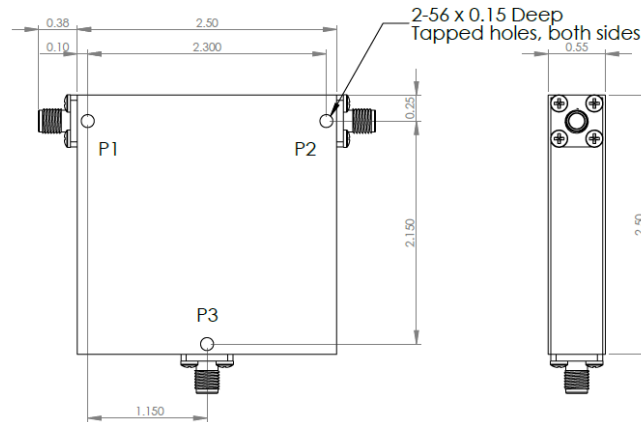

D3C1530-3 Dimensions

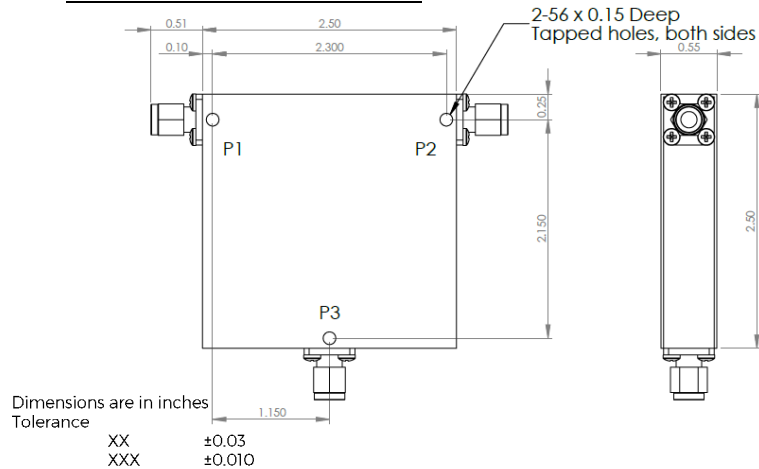

Type of Device	PN Suffix	Connector Configuration Input / Output	PN Example
Single Junction Circulator 3-Port Device Port 1 / Port 2 / Port 3	No Dash	Female / Female / Female	D3C1530
	-1	Male / Female / Female	D3C1530-1
	-2	Female / Male / Female	D3C1530-2
	-3	Male / Male / Male	D3C1530-3
	-4	Female / Female / Male	D3C1530-4
	-5	Male / Female / Male	D3C1530-5
	-6	Male / Male / Female	D3C1530-6
	-7	Female / Male / Male	D3C1530-7



MEASURED DATA

Part Number: D3C1530, P1→P2, P3 Terminated with 50Ω, +25°C

