

AFBR-59SMI2Z

250-MBd Compact 650-nm Transceiver for Data Communication over Polymer Optical Fiber (POF) Cables with SMI Connector

Data Sheet



Description

The Avago Technologies AFBR-59SMI2Z transceiver provides system designers with the ability to support serial communication with baud rates of up to 250 MBd over 2.2-mm jacketed standard polymer optical fiber (POF) with 1-mm core diameter and NA 0.5.

The SMI optical interconnect with its push-pull positive latching, with safe-release mechanism, provides secure, safe and easy to mate and de-mate optical connection for miscellaneous industrial and medical applications.

The AFBR-59SMI2Z is Laser Class 1, lead-free and compliant with RoHS.

Transmitter

The transmitter consists of a 650-nm LED, which is controlled by a fully integrated driver IC. The LED driver operates at 3.3V. It receives Low Voltage Differential Signaling (LVDS) electrical input, and converts it into a modulated current driving the LED. LED and driver IC are packaged in an optical subassembly.

The optimized lens system of the optical subassembly couples the emitted optical power very efficiently into 1-mm core POF cable.

Receiver

The receiver utilizes a fully integrated single chip solution, which provides excellent immunity to EMI and fast transient dV/dt rejection. The receiver directly converts light to a digital LVDS output signal and operates at 3.3-V nominal supply. The integrated receiver is packaged in an optical subassembly, which couples optical power efficiently from POF to the receiving PIN.

The receiver features an analog monitor output of the incoming optical signal. The monitor output provides an analog voltage proportional to the average optical input

power. In absence of receiver optical input signal, the receiver is in low power sleep mode and the differential output signal is pulled to ground. The receiver wakes up, when a valid optical input signal is detected.

Features

- Fast Ethernet communications over POF
- Data rates up to 250 MBd
- High EMI/EMC robustness
- SMI connector system
- Link lengths up to 50m POF
- 3.3V operation
- LVDS input and output data connections
- Analog monitoring output (RSSI)
- Operating temperature range from -40°C to $+85^{\circ}\text{C}$.
- RoHS compliant

Applications

- Industrial and medical applications
- Fast Ethernet

Package

The transceiver package contains the two optical subassemblies, which are mounted in the black housing for SMI optical connection.

The inserts are packages inside a conductive plastic inner housing, which provides additional immunity against EMI/EMC.

Pin Description and Recommended PCB Footprint

The AFBR-59SMI2Z has ten active signal pins (including supply voltage and ground pins) and two EMI shield solder posts. The EMI shield solder posts are isolated from transceiver internal circuit and should be connected to equipment chassis ground or signal ground.

Figure 1 shows the top view of the PCB footprint and pinout diagram.

Pin Description

Table 1 Pin Description

Pin No.	Name	Symbol	Pin No.	Name	Symbol
1	EMI Shield GND	—	7	Rx DC Supply Voltage	RVCC
2	Tx Data Input (Negative)	TD-	8	Rx Ground	RGND
3	Tx Data Input (Positive)	TD+	9	Rx Signal Strength Indicator	RSSI
4	Tx Ground	TGND	10	Rx Data Output (Negative)	RD-
5	Tx DC Supply Voltage	TVCC	11	Rx Data Output (Positive)	RD+
6	Tx Ground (optional)	TGND	12	EMI Shield GND	—

PCB Footprint

Figure 1 PCB Footprint and Pinout Diagram (Top View)

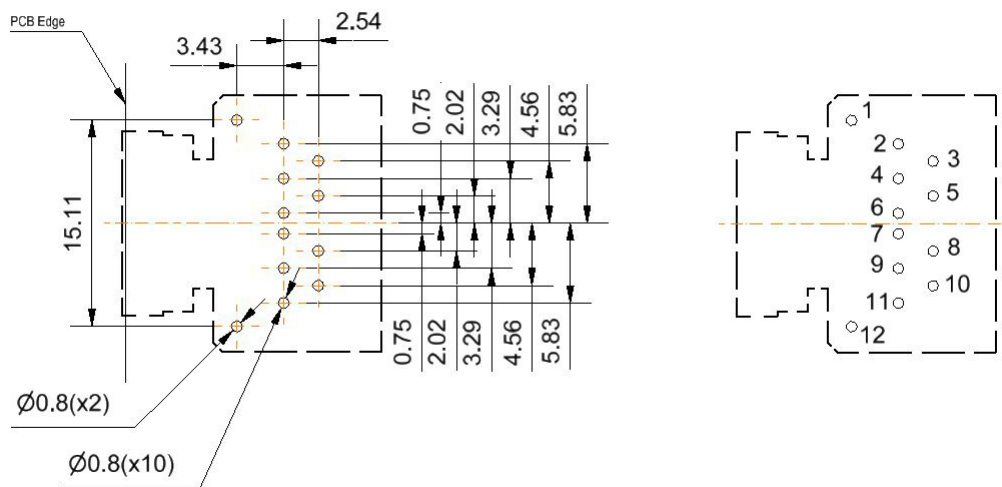

Notes:
Dimensions: mm
Recommended PCB thickness: 1.57 mm ± 0.08 mm

Regulatory Compliance Table

Table 2 Regulatory Compliance Table

Feature	Test Method	Performance
Electrostatic Discharge (ESD) to the Electrical Pins	ESD22-A114	Withstands up to 2-kV HBM applied between the electrical pins.
Immunity	Variation of IEC 61000-4-3	Typically shows no measurable effect from a 15-V/m field swept from 8 MHz to 1 GHz applied to the transceiver when mounted on a circuit board without chassis enclosure.
Component Recognition	Underwriter Laboratories	UL File #: E173874.
Eye Safety	EN 60825-1:52007	Laser Class 1 product (LED radiation only). TÜV certificate: R50217706. CAUTION Use of controls or adjustments of performance or procedures other than those specified herein might result in hazardous radiation exposure.

Absolute Maximum Ratings

Stresses in excess of the absolute maximum ratings can cause damage to the devices. Limits apply to each parameter in isolation. Absolute maximum ratings are those values beyond which damage to the device may occur if these limits are exceeded for other than a short period of time.

Table 3 Absolute Maximum Ratings

Parameter	Symbol	Min	Max	Unit
Supply Voltage	V_{CC}	-0.5	4.5	V
Storage Temperature	T_{STG}	-40	+85	°C
Lead Soldering Temperature ^a	T_{SOLD}	—	260	°C
Lead Soldering Time ^a	t_{SOLD}	—	10	s
Electrostatic Discharge Voltage Capability ^b	ESD	—	2	kV

a. The transceiver is Pb-free wave solderable. According to JEDEC J-STD-020D, the moisture sensitivity classification is MSL2a.

b. ESD capability for all pins HBM (human body model) according to JESD22-A114B.

Recommended Operating Conditions

Table 4 Recommended Operating Conditions

Parameter	Symbol	Min	Typ	Max	Unit
Operating Temperature	T_A	-40	—	+85	°C
DC Supply Voltage	V_{CC}	3.0	3.3	3.6	V
Baud Rate ^a	BR	10	—	250	MBd

a. Data rate of 250 Mb/s with 8b/10b coding.

NOTE All of the data in this specification refer to the operating conditions above and over lifetime unless otherwise stated.

Transmitter Electrical Characteristics

$T_A = -40^\circ\text{C}$ to $+85^\circ\text{C}$ unless otherwise specified; $3.0\text{V} \leq V_{CC} \leq 3.6\text{V}$.

Table 5 Transmitter Electrical Characteristics

Parameter	Symbol	Min	Typ	Max	Unit
Current Consumption	I_{CC}	—	29	40	mA
External Input termination Impedance	Z_{IN}	—	100	—	Ω
LVDS Input Voltage to Circuit Common	V_{IN}	0.8	—	2.2	V
LVDS Differential Input Voltage	$V_{IN-DIFF}$	200	—	1200	mV

Transmitter Optical Characteristics

$T_A = -40^\circ\text{C}$ to $+85^\circ\text{C}$ unless otherwise specified; $3.0\text{V} \leq V_{CC} \leq 3.6\text{V}$.

Table 6 Transmitter Optical Characteristics

Parameter	Symbol	Min	Typ	Max	Unit
Central Wavelength ^a	λ_C	635	650	675	nm
Spectral Bandwidth (RMS)	λ_W	—	—	17	nm
Average Output Power ^{a, b}	P_O	-8.5	—	-2.0	dBm
Optical Rise Time (20% to 80%) ^a	t_R	—	1.2	3.0	ns
Optical Fall Time (80% to 20%) ^a	t_F	—	1.2	3.0	ns
Extinction Ratio ^a	ER	10	12	—	dB
Duty Cycle Distortion ^a	DCD	—	—	1.0	ns
Random Jitter ^{a, c}	J_R	—	—	0.7	ns
Data Dependent Jitter ^a	J_{DD}	—	—	0.8	ns

- Measured at the end of 1m plastic optical fiber (POF) with PRBS 2^7-1 sequence.
- Minimum average output power specification value includes 1-dB degradation margin.
- Peak-to-peak measurement, based on BER = 2.5×10^{-10} .

Receiver Electrical Characteristics

$T_A = -40^\circ\text{C}$ to $+85^\circ\text{C}$ unless otherwise specified; $3.0\text{V} \leq V_{CC} \leq 3.6\text{V}$.

Table 7 Receiver Electrical Characteristics

Parameter	Symbol	Min	Typ	Max	Unit
Current Consumption	I_{CC}	—	23	30	mA
LVDS Output Common Voltage	V_{CM}	—	1.2	—	V
LVDS Output Differential Voltage Swing ^a	V_{O-DIFF}	500	—	800	mV
Output Rise Time (10% to 90%) ^a	t_R	—	1.1	3.0	ns
Output Fall Time (90% to 10%) ^a	t_F	—	1.1	3.0	ns
Duty Cycle Distortion ^a	DCD	—	—	1.0	ns
Random Jitter ^{a, b, c}	J_R	—	—	1.0	ns
Data Dependent Jitter ^a	J_{DD}	—	—	0.8	ns
Output Ratio for RSSI Pin ^d	I_{RSSI}/P	—	0.65	—	A/W
RSSI Output Voltage Range	V_{RSSI}	0	—	$V_{CC} - 1.5$	V
Wake Up Time after Sleep State	T_{WU}	—	—	1.0	ms

- Differential output signal is measured with reference transmitter source, 0.5m POF cable, and PRBS 2^7-1 sequence.
- Peak to peak measurement, based on $BER = 2.5 \times 10^{-10}$.
- Maximum random jitter at -15 dBm average optical input power is 0.4 ns.
- The RSSI current output has been verified with an external resistor $R_{RSSI} = 2$ k Ω .

Receiver Optical Characteristics

$T_A = -40^\circ\text{C}$ to $+85^\circ\text{C}$ unless otherwise specified; $3.0\text{V} \leq V_{CC} \leq 3.6\text{V}$.

Table 8 Receiver Optical Characteristics

Parameter	Symbol	Min	Typ	Max	Unit
Central Wavelength ^a	λ_C	635	650	675	nm
Minimum Receiver Input Power ^a	P_{IN-MIN}	-21	—	—	dBm
Maximum Receiver Input Power ^a	P_{IN-MAX}	—	—	-2.0	dBm

- Average optical power, measured with a PRBS 2^7-1 sequence, $BER = 2.5 \times 10^{-10}$.

Analog Monitoring Voltage (RSSI)

The Receiver Signal Strength Indicator (RSSI) is a monitoring output that delivers an output current proportional to the average incoming light. The typical variation of the analog monitoring voltage (across 2K shunt resistor) as a function of receiver optical input power for industrial temperature range is shown in Figure 2. The monitoring voltage varies linearly with the receiver optical input power. The variation over temperature is negligible for most applications.

For an almost noise-free RSSI-signal, smoothing components are recommended. A capacitor in parallel to the resistor on the RSSI output reduces potential high frequency signal parts. The use of a single 100-nF capacitor for signal smoothing is sufficient in most common applications, as shown in the recommended receiver circuitry in Figure 3.

To provide a suitable monitoring voltage across the shunt resistor, R_{RSSI} , its value should be chosen to the particular optical power situation of the specific application. The lower the optical receiver power, the higher the resistor value should be. Do not, however, override the max limit of V_{RSSI} .

Figure 2 Typical RSSI Output Voltage across $R_{RSSI} = 2\text{ k}\Omega$ vs. Optical Input Power

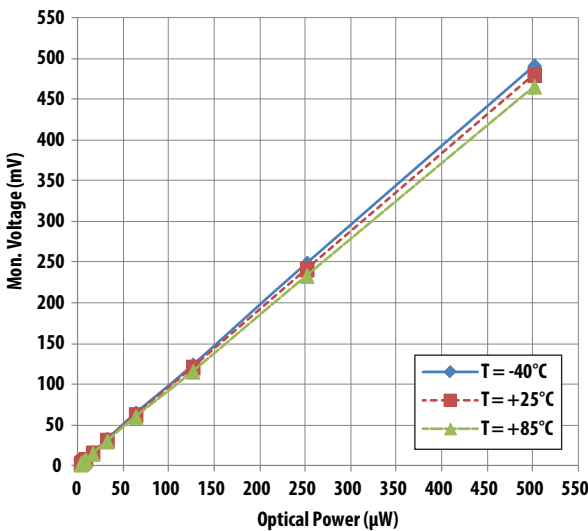

General LVDS Application Circuit

The recommended application circuit is shown in Figure 3.

Board Layout - Decoupling Circuit and Ground Planes

To achieve optimum performance from the AFBR-59SMI2Z transceiver module, it is important to take note of the following recommendations:

- A power supply decoupling circuit should be used to filter out noise and ensure optical product performance.
- A contiguous signal ground plane should be provided directly beneath the transceiver module for low inductance ground to signal return current.
- The shield posts should be connected to chassis ground or signal ground to provide optimum EMI and ESD performance.

These recommendations are in keeping with good high frequency board layout practices. However, the optimum grounding strategy depends on the overall system architecture.

Figure 3 shows the minimum external circuitry between AFBR-59SMI2Z transceiver module and PHY chip. AC-coupling is possible if the common mode voltage and voltage swing at the data lines are within the recommended values. Use the product information of the actual PHY Chip for connecting to the AFBR-59SMI2Z transceiver module.

Figure 3 General Application Circuit for LVDS Configuration

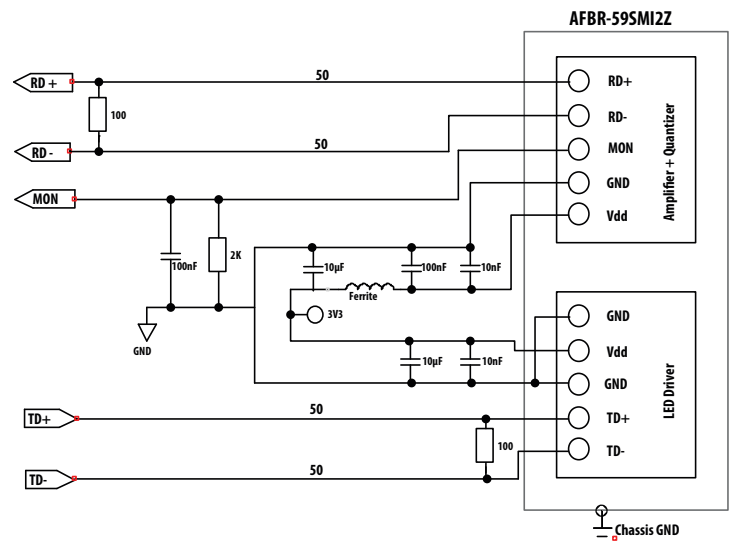

Mechanical Data – Package Outline

Figure 4 Package Outline Drawing

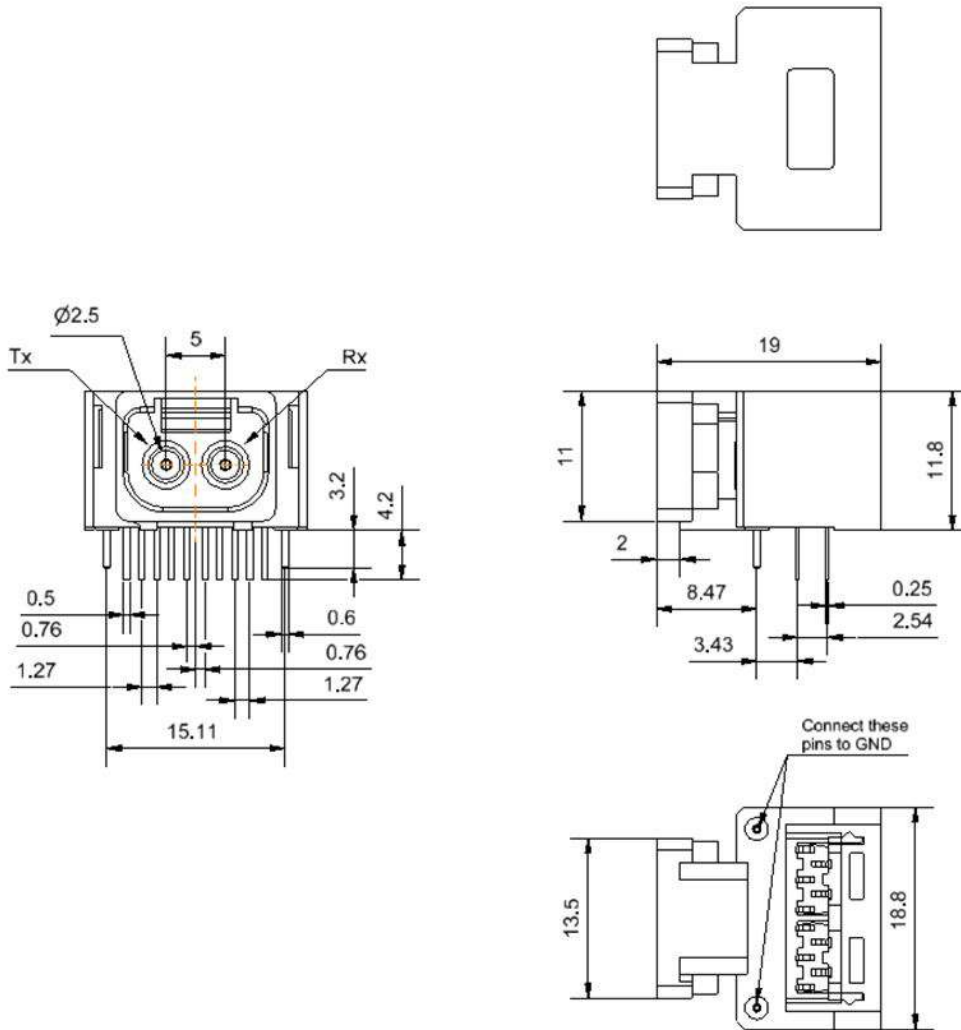

Notes:

Dimensions: mm.

Recommended PCB thickness: 1.57 mm \pm 0.08 mm.

Design related is a small gap between plastic part and dust plug possible. Function is nevertheless given.

For product information and a complete list of distributors, please go to our web site:
www.broadcom.com.

Broadcom, the pulse logo, Connecting everything, Avago Technologies, Avago, and the A logo are among the trademarks of Broadcom and/or its affiliates in the United States, certain other countries and/or the EU.

Copyright © 2016 by Broadcom. All Rights Reserved.

The term "Broadcom" refers to Broadcom Limited and/or its subsidiaries. For more information, please visit www.broadcom.com.

Broadcom reserves the right to make changes without further notice to any products or data herein to improve reliability, function, or design.

Information furnished by Broadcom is believed to be accurate and reliable. However, Broadcom does not assume any liability arising out of the application or use of this information, nor the application or use of any product or circuit described herein, neither does it convey any license under its patent rights nor the rights of others.

pub-005856 – November 7, 2016

