

# SN74AVCH2T45 2-Bit, 2-Supply, Bus Transceiver with Configurable Level-Shifting and Translation and 3-State Outputs

## 1 Features

- Available in the Texas Instruments NanoFree™ Package
- $V_{CC}$  Isolation
- 2-Rail Design
- I/Os are 4.6 V Tolerant
- Partial Power-Down-Mode Operation
- Bus Hold on Data Inputs
- Maximum Data Rates
  - 500 Mbps (1.8 V to 3.3 V)
  - 320 Mbps (< 1.8 V to 3.3 V)
  - 320 Mbps (Level-Shifting to 2.5 V or 1.8 V)
  - 280 Mbps (Level-Shifting to 1.5 V)
  - 240 Mbps (Level-Shifting to 1.2 V)
- Latch-Up Performance Exceeds 100 mA Per JESD 78, Class II
- ESD Protection Exceeds JESD 22

## 2 Applications

- Smartphone
- Servers
- Desktop PCs and Notebooks
- Other Portable Devices

## 3 Description

This 2-bit non-inverting bus transceiver uses two separate configurable power-supply rails. The A ports are designed to track  $V_{CCA}$  and accepts any supply voltage from 1.2 V to 3.6 V. The B ports are designed to track  $V_{CCB}$  and accepts any supply voltage from 1.2 V to 3.6 V. This allows for universal low-voltage bidirectional translation and level-shifting between any of the 1.2 V, 1.5 V, 1.8 V, 2.5 V, and 3.3 V voltage nodes.

The SN74AVCH2T45 is designed for asynchronous communication between two data buses. The logic levels of the direction-control (DIR pin) input activate either the B-port outputs or the A-port outputs. The device transmits data from the A bus to the B bus when the B-port outputs are activated and from the B bus to the A bus when the A-port outputs are activated. The SN74AVCH2T45 features active bus-hold circuitry, which holds unused or un-driven inputs at a valid logic state. TI does not recommend using pull-up or pull-down resistors with the bus-hold circuitry.

### Device Information<sup>(1)</sup>

PART NUMBER	PACKAGE	BODY SIZE (NOM)
SN74AVCH2T45	SSOP (8)	2.95 mm × 2.80 mm
	VSSOP (8)	2.30 mm × 2.00 mm
	DSBGA (8)	1.89 mm × 0.89 mm

(1) For all available packages, see the orderable addendum at the end of the data sheet.

### Logic Diagram (Positive Logic)

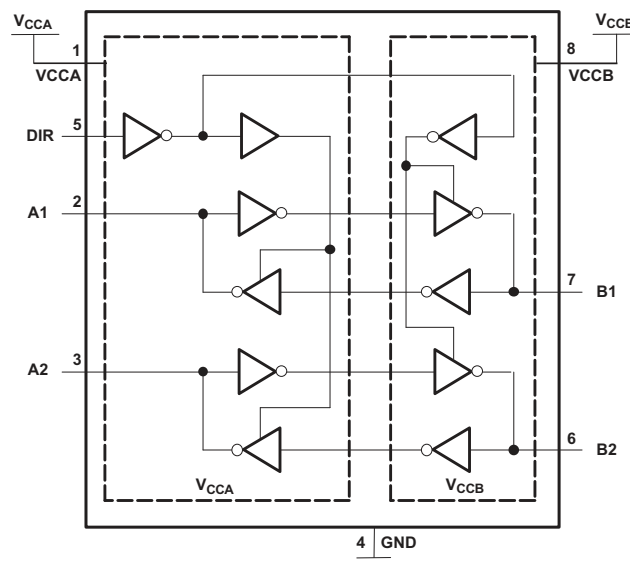

## Table of Contents

<b>1</b>	<b>Features</b> .....	<b>1</b>	<b>8</b>	<b>Parameter Measurement Information</b> .....	<b>13</b>
<b>2</b>	<b>Applications</b> .....	<b>1</b>	<b>9</b>	<b>Detailed Description</b> .....	<b>14</b>
<b>3</b>	<b>Description</b> .....	<b>1</b>	9.1	Overview .....	14
<b>4</b>	<b>Revision History</b> .....	<b>3</b>	9.2	Functional Block Diagram .....	14
<b>5</b>	<b>Description (Continued)</b> .....	<b>4</b>	9.3	Feature Description.....	15
<b>6</b>	<b>Pin Configurations and Functions</b> .....	<b>4</b>	9.4	Device Functional Modes.....	15
<b>7</b>	<b>Specifications</b> .....	<b>5</b>	<b>10</b>	<b>Application and Implementation</b> .....	<b>16</b>
7.1	Absolute Maximum Ratings .....	5	10.1	Application Information.....	16
7.2	ESD Ratings.....	5	10.2	Typical Applications .....	16
7.3	Recommended Operating Conditions .....	6	<b>11</b>	<b>Power Supply Recommendations</b> .....	<b>20</b>
7.4	Thermal Information .....	7	<b>12</b>	<b>Layout</b> .....	<b>20</b>
7.5	Electrical Characteristics .....	7	12.1	Layout Guidelines .....	20
7.6	Switching Characteristics: $V_{CCA} = 1.2\text{ V}$ .....	8	12.2	Layout Example .....	20
7.7	Switching Characteristics: $V_{CCA} = 1.5\text{ V}$ .....	9	<b>13</b>	<b>Device and Documentation Support</b> .....	<b>21</b>
7.8	Switching Characteristics: $V_{CCA} = 1.8\text{ V}$ .....	10	13.1	Documentation Support .....	21
7.9	Switching Characteristics: $V_{CCA} = 2.5\text{ V}$ .....	10	13.2	Trademarks .....	21
7.10	Switching Characteristics: $V_{CCA} = 3.3\text{ V}$ .....	11	13.3	Electrostatic Discharge Caution.....	21
7.11	Operating Characteristics.....	11	13.4	Glossary .....	21
7.12	Typical Characteristics .....	12	<b>14</b>	<b>Mechanical, Packaging, and Orderable Information</b> .....	<b>21</b>

## 4 Revision History

Changes from Revision G (April 2015) to Revision H	Page
• Added additional applications. ....	1
• Updated Overview section. ....	14
• Updated Layout Guidelines section. ....	20

---

Changes from Revision F (November 2007) to Revision G	Page
• Added <i>ESD Ratings</i> table, <i>Feature Description</i> section, <i>Device Functional Modes</i> , <i>Application and Implementation</i> section, <i>Power Supply Recommendations</i> section, <i>Layout</i> section, <i>Device and Documentation Support</i> section, and <i>Mechanical, Packaging, and Orderable Information</i> section .....	1

## 5 Description (Continued)

This device is fully specified for partial-power-down applications using  $I_{off}$ . The  $I_{off}$  circuitry disables the outputs, preventing damaging current backflow through the device when it is powered down. The  $V_{CC}$  isolation feature ensures that if either  $V_{CC}$  input is at GND, then both outputs are in the high-impedance state. The bus-hold circuitry on the powered-up side always stays active.

Active bus-hold circuitry holds unused or un-driven inputs at a valid logic state. NanoFree package technology is a major breakthrough in IC packaging concepts, using the die as the package.

## 6 Pin Configurations and Functions

**DCT and DCU Packages  
8-Pin SSOP and VSSOP  
Top View**

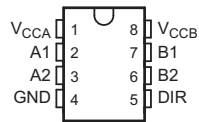

**YZP Package  
8-Pin DSBGA  
Bottom View**

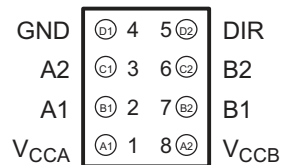

### Pin Functions

NAME	PIN		DESCRIPTION
	SSOP, VSSOP	DSBGA	
VCCA	1	A1	Supply Voltage A
VCCB	8	A2	Supply Voltage B
GND	4	D1	Ground
A1	2	B1	Output or input depending on state of DIR. Output level depends on $V_{CCA}$ .
A2	3	C1	Output or input depending on state of DIR. Output level depends on $V_{CCA}$ .
B1	7	B2	Output or input depending on state of DIR. Output level depends on $V_{CCB}$ .
B2	6	C2	Output or input depending on state of DIR. Output level depends on $V_{CCB}$ .
DIR	5	D2	Direction Pin, Connect to GND or to VCCA.

## 7 Specifications

### 7.1 Absolute Maximum Ratings

over operating free-air temperature range (unless otherwise noted)<sup>(1)</sup>

		MIN	MAX	UNIT	
$V_{CCA}$ $V_{CCB}$	Supply voltage	-0.5	4.6	V	
$V_I$	Input voltage <sup>(2)</sup>	I/O ports (A port)	-0.5	4.6	V
		I/O ports (B port)	-0.5	4.6	
		Control inputs	-0.5	4.6	
$V_O$	Voltage range applied to any output in the high-impedance or power-off state <sup>(2)</sup>	A port	-0.5	4.6	V
		B port	-0.5	4.6	
$V_O$	Voltage range applied to any output in the high or low state <sup>(2)(3)</sup>	A port	-0.5	$V_{CCA} + 0.5$	V
		B port	-0.5	$V_{CCB} + 0.5$	
$I_{IK}$	Input clamp current	$V_I < 0$	-50	mA	
$I_{OK}$	Output clamp current	$V_O < 0$	-50	mA	
$I_O$	Continuous output current		±50	mA	
	Continuous current through $V_{CCA}$ , $V_{CCB}$ , or GND		±100	mA	
$T_J$	Junction temperature	-40	150	°C	
$T_{stg}$	Storage temperature	-65	150	°C	

- (1) Stresses beyond those listed under *Absolute Maximum Ratings* may cause permanent damage to the device. These are stress ratings only, which do not imply functional operation of the device at these or any other conditions beyond those indicated under *Recommended Operating Conditions*. Exposure to absolute-maximum-rated conditions for extended periods may affect device reliability.
- (2) The input voltage and output negative-voltage ratings may be exceeded if the input and output current ratings are observed.
- (3) The output positive-voltage rating may be exceeded up to 4.6 V maximum if the output current rating is observed.

### 7.2 ESD Ratings

		VALUE	UNIT
$V_{(ESD)}$	Electrostatic discharge	Human body model (HBM), per ANSI/ESDA/JEDEC JS-001 <sup>(1)</sup>	±8000
		Charged-device model (CDM), per JEDEC specification JESD22-C101 <sup>(2)</sup>	±1000
		Machine Model (MM), Per JEDEC specification JESD22-A115-A	±200

- (1) JEDEC document JEP155 states that 500-V HBM allows safe manufacturing with a standard ESD control process.
- (2) JEDEC document JEP157 states that 250-V CDM allows safe manufacturing with a standard ESD control process.

### 7.3 Recommended Operating Conditions

 over operating free-air temperature range (unless otherwise noted)<sup>(1)(2)(3)</sup>

		$V_{CCI}^{(4)}$	$V_{CCO}^{(5)}$	MIN	NOM	MAX	UNIT
$V_{CCA}$	Supply voltage			1.2		3.6	V
$V_{CCB}$	Supply voltage			1.2		3.6	V
$V_{IH}$	High-level input voltage	Data inputs <sup>(2)</sup>	1.2 V to 1.95 V	$V_{CCI}^{(4)} \times 0.65$			V
			1.95 V to 2.7 V	1.6			
			2.7 V to 3.6 V	2			
$V_{IL}$	Low-level input voltage	Data inputs <sup>(2)</sup>	1.2 V to 1.95 V	$V_{CCI}^{(4)} \times 0.35$			V
			1.95 V to 2.7 V	0.7			
			2.7 V to 3.6 V	0.8			
$V_{IH}$	High-level input voltage	DIR (referenced to $V_{CCA}$ ) <sup>(3)</sup>	1.2 V to 1.95 V	$V_{CCA} \times 0.65$			V
			1.95 V to 2.7 V	1.6			
			2.7 V to 3.6 V	2			
$V_{IL}$	Low-level input voltage	DIR (referenced to $V_{CCA}$ ) <sup>(3)</sup>	1.2 V to 1.95 V	$V_{CCA} \times 0.35$			V
			1.95 V to 2.7 V	0.7			
			2.7 V to 3.6 V	0.8			
$V_I$	Input voltage			0		3.6	V
$V_O$	Output voltage	Active state		0		$V_{CCO}^{(5)}$	V
		3-state		0		3.6	
$I_{OH}$	High-level output current		1.2 V			–3	mA
			1.4 V to 1.6 V			–6	
			1.65 V to 1.95 V			–8	
			2.3 V to 2.7 V			–9	
			3 V to 3.6 V			–12	
$I_{OL}$	Low-level output current		1.2 V			3	mA
			1.4 V to 1.6 V			6	
			1.65 V to 1.95 V			8	
			2.3 V to 2.7 V			9	
			3 V to 3.6 V			12	
$\Delta t/\Delta v$	Input transition rise or fall rate					5	ns/V
$T_A$	Operating free-air temperature			–40		85	°C

(1) All unused data inputs of the device must be held at  $V_{CCI}$  or GND to ensure proper device operation. Refer to the TI application report, *Implications of Slow or Floating CMOS Inputs*, [SCBA004](#).

(2) For  $V_{CCI}$  values not specified in the data sheet,  $V_{IH}$  min =  $V_{CCI} \times 0.7$  V,  $V_{IL}$  max =  $V_{CCI} \times 0.3$  V.

(3) For  $V_{CCI}$  values not specified in the data sheet,  $V_{IH}$  min =  $V_{CCA} \times 0.7$  V,  $V_{IL}$  max =  $V_{CCA} \times 0.3$  V.

(4)  $V_{CCI}$  is the voltage associated with the input port supply  $V_{CCA}$  or  $V_{CCB}$ .

(5)  $V_{CCO}$  is the voltage associated with the output port supply  $V_{CCA}$  or  $V_{CCB}$ .

## 7.4 Thermal Information

THERMAL METRIC <sup>(1)</sup>		SN74AVCH2T45			UNIT
		DCT (SSOP)	DCU (VSSOP)	YZP (DSBGA)	
		8 PINS	8 PINS	8 PINS	
R <sub>θJA</sub>	Junction-to-ambient thermal resistance	194.4	199.3	105.8	°C/W
R <sub>θJC(top)</sub>	Junction-to-case (top) thermal resistance	124.7	76.2	1.6	
R <sub>θJB</sub>	Junction-to-board thermal resistance	106.8	80.6	10.8	
ψ <sub>JT</sub>	Junction-to-top characterization parameter	49.8	7.1	3.1	
ψ <sub>JB</sub>	Junction-to-board characterization parameter	105.8	80.1	10.8	

(1) For more information about traditional and new thermal metrics, see the *IC Package Thermal Metrics* application report, [SPRA953](#).

## 7.5 Electrical Characteristics

over recommended operating free-air temperature range (unless otherwise noted)<sup>(1)(2)</sup>

PARAMETER	TEST CONDITIONS	V <sub>CCA</sub>	V <sub>CCB</sub>	T <sub>A</sub> = 25°C			–40°C to 85°C			UNIT
				MIN	TYP	MAX	MIN	TYP	MAX	
V <sub>OH</sub> <sup>(3)</sup>	I <sub>OH</sub> = –100 μA I <sub>OH</sub> = –3 mA I <sub>OH</sub> = –6 mA I <sub>OH</sub> = –8 mA I <sub>OH</sub> = –9 mA I <sub>OH</sub> = –12 mA	V <sub>I</sub> = V <sub>IH</sub>	1.2 V to 3.6 V	1.2 V to 3.6 V				V <sub>CCO</sub> – 0.2		V
			1.2 V	1.2 V	0.95					
			1.4 V	1.4 V		1.05				
			1.65 V	1.65 V		1.2				
			2.3 V	2.3 V		1.75				
			3 V	3 V		2.3				
V <sub>OL</sub> <sup>(3)</sup>	I <sub>OL</sub> = 100 μA I <sub>OL</sub> = 3 mA I <sub>OL</sub> = 6 mA I <sub>OL</sub> = 8 mA I <sub>OL</sub> = 9 mA I <sub>OL</sub> = 12 mA	V <sub>I</sub> = V <sub>IL</sub>	1.2 V to 3.6 V	1.2 V to 3.6 V				0.2		V
			1.2 V	1.2 V	0.15					
			1.4 V	1.4 V		0.35				
			1.65 V	1.65 V		0.45				
			2.3 V	2.3 V		0.55				
			3 V	3 V		0.7				
I <sub>I</sub> <sup>(3)</sup>	DIR input	V <sub>I</sub> = V <sub>CCA</sub> or GND	1.2 V to 3.6 V	1.2 V to 3.6 V	±0.025	±0.25			±1	μA
I <sub>BHL</sub> <sup>(4)</sup>			V <sub>I</sub> = 0.42 V	1.2 V	1.2 V	25				μA
			V <sub>I</sub> = 0.49 V	1.4 V	1.4 V			15		
			V <sub>I</sub> = 0.58 V	1.65 V	1.65 V			25		
			V <sub>I</sub> = 0.7 V	2.3 V	2.3 V			45		
			V <sub>I</sub> = 0.8 V	3.3 V	3.3 V			100		
I <sub>BHH</sub> <sup>(5)</sup>			V <sub>I</sub> = 0.78 V	1.2 V	1.2 V	–25				μA
			V <sub>I</sub> = 0.91 V	1.4 V	1.4 V			–15		
			V <sub>I</sub> = 1.07 V	1.65 V	1.65 V			–25		
			V <sub>I</sub> = 1.6 V	2.3 V	2.3 V			–45		
			V <sub>I</sub> = 2 V	3.3 V	3.3 V			–100		
I <sub>BHLO</sub> <sup>(6)</sup>		V <sub>I</sub> = 0 to V <sub>CC</sub>	1.2 V	1.2 V	50				μA	
			1.6 V	1.6 V			125			
			1.95 V	1.95 V			200			
			2.7 V	2.7 V			300			
			3.6 V	3.6 V			500			

(1) V<sub>CCO</sub> is the voltage associated with the output port supply V<sub>CCA</sub> or V<sub>CCB</sub>.

(2) V<sub>CCI</sub> is the voltage associated with the input port supply V<sub>CCA</sub> or V<sub>CCB</sub>.

(3) V<sub>OH</sub>: Output High Voltage; V<sub>OL</sub>: Output Low Voltage; I<sub>I</sub>: Control Input Current.

(4) The bus-hold circuit can sink at least the minimum low sustaining current at V<sub>IL</sub> maximum. I<sub>BHL</sub> should be measured after lowering V<sub>IN</sub> to GND and then raising it to V<sub>IL</sub> maximum.

(5) The bus-hold circuit can source at least the minimum high sustaining current at V<sub>IH</sub> minimum. I<sub>BHH</sub> should be measured after raising V<sub>IN</sub> to V<sub>CC</sub> and then lowering it to V<sub>IH</sub> minimum.

(6) An external driver must source at least I<sub>BHLO</sub> to switch this node from low to high.

**Electrical Characteristics (continued)**

 over recommended operating free-air temperature range (unless otherwise noted)<sup>(1)(2)</sup>

PARAMETER	TEST CONDITIONS	V <sub>CCA</sub>	V <sub>CCB</sub>	T <sub>A</sub> = 25°C			–40°C to 85°C			UNIT
				MIN	TYP	MAX	MIN	TYP	MAX	
I <sub>BHHO</sub> <sup>(7)</sup>	V <sub>I</sub> = 0 to V <sub>CC</sub>	1.2 V	1.2 V	–50						μA
		1.6 V	1.6 V				–125			
		1.95 V	1.95 V				–200			
		2.7 V	2.7 V				–300			
		3.6 V	3.6 V				–500			
I <sub>off</sub> <sup>(8)</sup>	A port	V <sub>I</sub> or V <sub>O</sub> = 0 to 3.6 V	0 V	0 V to 3.6 V	±0.1	±1				μA
	B port		0 V to 3.6 V	0 V	±0.1	±1				
I <sub>OZ</sub> <sup>(8)</sup>	B port	V <sub>O</sub> = V <sub>CCO</sub> or GND, V <sub>I</sub> = V <sub>CCI</sub> or GND	0 V	3.6 V	±0.5	±2.5				μA
	A port		3.6 V	0 V	±0.5	±2.5				
I <sub>CCA</sub> <sup>(8)</sup>	V <sub>I</sub> = V <sub>CCI</sub> or GND, I <sub>O</sub> = 0	1.2 V to 3.6 V	1.2 V to 3.6 V				10			μA
		0 V	3.6 V				–2			
		3.6 V	0 V				10			
I <sub>CCB</sub> <sup>(8)</sup>	V <sub>I</sub> = V <sub>CCB</sub> or GND, I <sub>O</sub> = 0	1.2 V to 3.6 V	1.2 V to 3.6 V				10			μA
		0 V	3.6 V				10			
		3.6 V	0 V				–2			
I <sub>CCA</sub> + I <sub>CCB</sub>	V <sub>I</sub> = V <sub>CCB</sub> or GND, I <sub>O</sub> = 0	1.2 V to 3.6 V	1.2 V to 3.6 V				20			μA
C <sub>i</sub>	Control inputs	V <sub>I</sub> = 3.3 V or GND	3.3 V	3.3 V	2.5					pF
C <sub>io</sub>	A or B port	V <sub>I</sub> = 3.3 V or GND	3.3 V	3.3 V	6					pF

(7) An external driver must sink at least I<sub>BHHO</sub> to switch this node from high to low.

(8) I<sub>off</sub>: Partial Power Down Output current; I<sub>OZ</sub>: Hi-Z Output Current; I<sub>CCA</sub>: Supply A Current; I<sub>CCB</sub>: Supply B Current.

**7.6 Switching Characteristics: V<sub>CCA</sub> = 1.2 V**

 over recommended operating free-air temperature range, V<sub>CCA</sub> = 1.2 V (see Figure 7)

PARAMETER	FROM (INPUT)	TO (OUTPUT)	V <sub>CCB</sub> = 1.2 V	V <sub>CCB</sub> = 1.5 V	V <sub>CCB</sub> = 1.8 V	V <sub>CCB</sub> = 2.5 V	V <sub>CCB</sub> = 3.3 V	UNIT
			TYP	TYP	TYP	TYP	TYP	
t <sub>PLH</sub> <sup>(1)</sup>	A	B	3.1	2.6	2.4	2.2	2.2	ns
t <sub>PHL</sub> <sup>(1)</sup>			3.1	2.6	2.4	2.2	2.2	
t <sub>PLH</sub> <sup>(1)</sup>	B	A	3.4	3.1	3	2.9	2.9	ns
t <sub>PHL</sub> <sup>(1)</sup>			3.4	3.1	3	2.9	2.9	
t <sub>PHZ</sub> <sup>(1)</sup>	DIR	A	5.2	5.2	5.1	5	4.8	ns
t <sub>PLZ</sub> <sup>(1)</sup>			5.2	5.2	5.1	5	4.8	
t <sub>PHZ</sub> <sup>(1)</sup>	DIR	B	5	4	3.8	2.8	3.2	ns
t <sub>PLZ</sub> <sup>(1)</sup>			5	4	3.8	2.8	3.2	
t <sub>PZH</sub> <sup>(1)(2)</sup>	DIR	A	8.4	7.1	6.8	5.7	6.1	ns
t <sub>PZL</sub> <sup>(1)(2)</sup>			8.4	7.1	6.8	5.7	6.1	
t <sub>PZH</sub> <sup>(1)(2)</sup>	DIR	B	8.3	7.8	7.5	7.2	7	ns
t <sub>PZL</sub> <sup>(1)(2)</sup>			8.3	7.8	7.5	7.2	7	

(1) t<sub>PLH</sub>: Low-to-high Propagation Delay; t<sub>PHL</sub>: High-to-Low Propagation Delay; t<sub>PHZ</sub>: High-to-Hi-Z Propagation Delay; t<sub>PLZ</sub>: Low-to-Hi-Z Propagation Delay; t<sub>PZH</sub>: Hi-Z-to-High Propagation Delay; t<sub>PZL</sub>: Hi-Z-to-Low Propagation Delay

(2) The enable time is a calculated value derived using the formula shown in the [Enable Times](#) section.



## 7.7 Switching Characteristics: $V_{CCA} = 1.5\text{ V}$

over recommended operating free-air temperature range,  $V_{CCA} = 1.5\text{ V} \pm 0.1\text{ V}$  (see [Figure 7](#))

PARAMETER	FROM (INPUT)	TO (OUTPUT)	$V_{CCB} = 1.2\text{ V}$	$V_{CCB} = 1.5\text{ V} \pm 0.1\text{ V}$		$V_{CCB} = 1.8\text{ V} \pm 0.15\text{ V}$		$V_{CCB} = 2.5\text{ V} \pm 0.2\text{ V}$		$V_{CCB} = 3.3\text{ V} \pm 0.3\text{ V}$		UNIT
			TYP	MIN	MAX	MIN	MAX	MIN	MAX	MIN	MAX	
$t_{PLH}^{(1)}$	A	B	2.8	0.7	5.4	0.5	4.6	0.4	3.7	0.3	3.5	ns
$t_{PHL}^{(1)}$			2.8	0.7	5.4	0.5	4.6	0.4	3.7	0.3	3.5	
$t_{PLH}^{(1)}$	B	A	2.7	0.8	5.4	0.7	5.2	0.6	4.9	0.5	4.7	ns
$t_{PHL}^{(1)}$			2.7	0.8	5.4	0.7	5.2	0.6	4.9	0.5	4.7	
$t_{PHZ}^{(1)}$	DIR	A	3.9	1.3	8.5	1.3	7.8	1.1	7.7	1.4	7.6	ns
$t_{PLZ}^{(1)}$			3.9	1.3	8.5	1.3	7.8	1.1	7.7	1.4	7.6	
$t_{PHZ}^{(1)}$	DIR	B	4.7	1.1	7	1.4	6.9	1.2	6.9	1.7	7.1	ns
$t_{PLZ}^{(1)}$			4.7	1.1	7	1.4	6.9	1.2	6.9	1.7	7.1	
$t_{PZH}^{(1)(2)}$	DIR	A	7.4	12.4		12.1		11.8		11.8		ns
$t_{PZL}^{(1)(2)}$			7.4	12.4		12.1		11.8		11.8		
$t_{PZH}^{(1)(2)}$	DIR	B	6.7	13.9		12.4		11.4		11.1		ns
$t_{PZL}^{(1)(2)}$			6.7	13.9		12.4		11.4		11.1		

- (1)  $t_{PLH}$ : Low-to-high Propagation Delay;  $t_{PHL}$ : High-to-Low Propagation Delay;  $t_{PHZ}$ : High-to-Hi-Z Propagation Delay;  $t_{PLZ}$ : Low-to-Hi-Z Propagation Delay;  $t_{PZH}$ : Hi-Z-to-High Propagation Delay;  $t_{PZL}$ : Hi-Z-to-Low Propagation Delay  
 (2) The enable time is a calculated value derived using the formula shown in the [Enable Times](#) section.

## 7.8 Switching Characteristics: $V_{CCA} = 1.8\text{ V}$

 over recommended operating free-air temperature range,  $V_{CCA} = 1.8\text{ V} \pm 0.15\text{ V}$  (see [Figure 7](#))

PARAMETER	FROM (INPUT)	TO (OUTPUT)	$V_{CCB} = 1.2\text{ V}$		$V_{CCB} = 1.5\text{ V} \pm 0.1\text{ V}$		$V_{CCB} = 1.8\text{ V} \pm 0.15\text{ V}$		$V_{CCB} = 2.5\text{ V} \pm 0.2\text{ V}$		$V_{CCB} = 3.3\text{ V} \pm 0.3\text{ V}$		UNIT
			TYP	MIN	MAX	MIN	MAX	MIN	MAX	MIN	MAX	MIN	
$t_{PLH}^{(1)}$	A	B	2.7	0.5	5.2	0.4	4.3	0.2	3.4	0.2	3.1	ns	
$t_{PHL}^{(1)}$			2.7	0.5	5.2	0.4	4.3	0.2	3.4	0.2	3.1		
$t_{PLH}^{(1)}$	B	A	2.4	0.7	4.7	0.5	4.4	0.5	4	0.4	3.8	ns	
$t_{PHL}^{(1)}$			2.4	0.7	4.7	0.5	4.4	0.5	4	0.4	3.8		
$t_{PHZ}^{(1)}$	DIR	A	3.7	1.3	8.1	0.7	6.9	1.4	5.3	1.1	5.2	ns	
$t_{PLZ}^{(1)}$			3.7	1.3	8.1	0.7	6.9	1.4	5.3	1.1	5.2		
$t_{PHZ}^{(1)}$	DIR	B	4.4	1.3	5.8	1.3	5.9	0.8	5.7	1.5	5.9	ns	
$t_{PLZ}^{(1)}$			4.4	1.3	5.8	1.3	5.9	0.8	5.7	1.5	5.9		
$t_{PZH}^{(1)(2)}$	DIR	A	6.8		10.5		10.3		9.7		9.7	ns	
$t_{PZL}^{(1)(2)}$			6.8		10.5		10.3		9.7		9.7		
$t_{PZH}^{(1)(2)}$	DIR	B	6.4		13.3		11.2		8.7		8.3	ns	
$t_{PZL}^{(1)(2)}$			6.4		13.3		11.2		8.7		8.3		

- (1)  $t_{PLH}$ : Low-to-high Propagation Delay;  $t_{PHL}$ : High-to-Low Propagation Delay;  $t_{PHZ}$ : High-to-Hi-Z Propagation Delay;  $t_{PLZ}$ : Low-to-Hi-Z Propagation Delay;  $t_{PZH}$ : Hi-Z-to-High Propagation Delay;  $t_{PZL}$ : Hi-Z-to-Low Propagation Delay  
 (2) The enable time is a calculated value derived using the formula shown in the [Enable Times](#) section.

## 7.9 Switching Characteristics: $V_{CCA} = 2.5\text{ V}$

 over recommended operating free-air temperature range,  $V_{CCA} = 2.5\text{ V} \pm 0.2\text{ V}$  (see [Figure 7](#))

PARAMETER	FROM (INPUT)	TO (OUTPUT)	$V_{CCB} = 1.2\text{ V}$		$V_{CCB} = 1.5\text{ V} \pm 0.1\text{ V}$		$V_{CCB} = 1.8\text{ V} \pm 0.15\text{ V}$		$V_{CCB} = 2.5\text{ V} \pm 0.2\text{ V}$		$V_{CCB} = 3.3\text{ V} \pm 0.3\text{ V}$		UNIT
			TYP	MIN	MAX	MIN	MAX	MIN	MAX	MIN	MAX	MIN	
$t_{PLH}^{(1)}$	A	B	2.6	0.4	4.9	0.2	4	0.2	3	0.2	2.6	ns	
$t_{PHL}^{(1)}$			2.6	0.4	4.9	0.2	4	0.2	3	0.2	2.6		
$t_{PLH}^{(1)}$	B	A	2.1	0.6	3.8	0.5	3.4	0.4	3	0.3	2.8	ns	
$t_{PHL}^{(1)}$			2.1	0.6	3.8	0.5	3.4	0.4	3	0.3	2.8		
$t_{PHZ}^{(1)}$	DIR	A	2.4	0.7	7.9	0.8	6.4	0.8	5	0.5	4.3	ns	
$t_{PLZ}^{(1)}$			2.4	0.7	7.9	0.8	6.4	0.8	5	0.5	4.3		
$t_{PHZ}^{(1)}$	DIR	B	3.8	1	4.3	0.6	4.3	0.5	4.2	1.1	4.1	ns	
$t_{PLZ}^{(1)}$			3.8	1	4.3	0.6	4.3	0.5	4.2	1.1	4.1		
$t_{PZH}^{(1)(2)}$	DIR	A	5.9		8.5		7.7		7.2		6.9	ns	
$t_{PZL}^{(1)(2)}$			5.9		8.5		7.7		7.2		6.9		
$t_{PZH}^{(1)(2)}$	DIR	B	5		12.8		10.4		8		6.9	ns	
$t_{PZL}^{(1)(2)}$			5		12.8		10.4		8		6.9		

- (1)  $t_{PLH}$ : Low-to-high Propagation Delay;  $t_{PHL}$ : High-to-Low Propagation Delay;  $t_{PHZ}$ : High-to-Hi-Z Propagation Delay;  $t_{PLZ}$ : Low-to-Hi-Z Propagation Delay;  $t_{PZH}$ : Hi-Z-to-High Propagation Delay;  $t_{PZL}$ : Hi-Z-to-Low Propagation Delay  
 (2) The enable time is a calculated value derived using the formula shown in the [Enable Times](#) section.

## 7.10 Switching Characteristics: $V_{CCA} = 3.3\text{ V}$

over recommended operating free-air temperature range,  $V_{CCA} = 3.3\text{ V} \pm 0.3\text{ V}$  (see [Figure 7](#))

PARAMETER	FROM (INPUT)	TO (OUTPUT)	$V_{CCB} = 1.2\text{ V}$	$V_{CCB} = 1.5\text{ V} \pm 0.1\text{ V}$		$V_{CCB} = 1.8\text{ V} \pm 0.15\text{ V}$		$V_{CCB} = 2.5\text{ V} \pm 0.2\text{ V}$		$V_{CCB} = 3.3\text{ V} \pm 0.3\text{ V}$		UNIT
			TYP	MIN	MAX	MIN	MAX	MIN	MAX	MIN	MAX	
$t_{PLH}^{(1)}$	A	B	2.5	0.3	4.7	0.2	3.8	0.2	2.8	0.2	2.4	ns
$t_{PHL}^{(1)}$			2.5	0.3	4.7	0.2	3.8	0.2	2.8	0.2	2.4	
$t_{PLH}^{(1)}$	B	A	2.1	0.6	3.6	0.4	3.1	0.3	2.6	0.3	2.4	ns
$t_{PHL}^{(1)}$			2.1	0.6	3.6	0.4	3.1	0.3	2.6	0.3	2.4	
$t_{PHZ}^{(1)}$	DIR	A	2.9	1.1	8	1	6.5	1.3	4.7	1.2	4	ns
$t_{PLZ}^{(1)}$			2.9	1.1	8	1	6.5	1.3	4.7	1.2	4	
$t_{PHZ}^{(1)}$	DIR	B	3.4	0.5	6.6	0.3	5.6	0.3	4.6	1.1	4.2	ns
$t_{PLZ}^{(1)}$			3.4	0.5	6.6	0.3	5.6	0.3	4.6	1.1	4.2	
$t_{PZH}^{(1)(2)}$	DIR	A	5.5	10.2		8.7		7.2		6.6		ns
$t_{PZL}^{(1)(2)}$			5.5	10.2		8.7		7.2		6.6		
$t_{PZH}^{(1)(2)}$	DIR	B	5.4	12.7		10.3		7.5		6.4		ns
$t_{PZL}^{(1)(2)}$			5.4	12.7		10.3		7.5		6.4		

- (1)  $t_{PLH}$ : Low-to-high Propagation Delay;  $t_{PHL}$ : High-to-Low Propagation Delay;  $t_{PHZ}$ : High-to-Hi-Z Propagation Delay;  $t_{PLZ}$ : Low-to-Hi-Z Propagation Delay;  $t_{PZH}$ : Hi-Z-to-High Propagation Delay;  $t_{PZL}$ : Hi-Z-to-Low Propagation Delay  
(2) The enable time is a calculated value derived using the formula shown in the [Enable Times](#) section.

## 7.11 Operating Characteristics

 $T_A = 25^\circ\text{C}$ 

PARAMETER		TEST CONDITIONS	$V_{CCA} =$ $V_{CCB} = 1.2\text{ V}$	$V_{CCA} =$ $V_{CCB} = 1.5\text{ V}$	$V_{CCA} =$ $V_{CCB} = 1.8\text{ V}$	$V_{CCA} =$ $V_{CCB} = 2.5\text{ V}$	$V_{CCA} =$ $V_{CCB} = 3.3\text{ V}$	UNIT
			TYP	TYP	TYP	TYP	TYP	
$C_{pdA}^{(1)}$	A-port input, B-port output	$C_L = 0,$ $f = 10\text{ MHz},$ $t_r^{(2)} = t_f^{(2)} = 1\text{ ns}$	3	3	3	3	4	pF
	B-port input, A-port output		13	13	14	15	15	
$C_{pdB}^{(1)}$	A-port input, B-port output	$C_L = 0,$ $f = 10\text{ MHz},$ $t_r^{(2)} = t_f^{(2)} = 1\text{ ns}$	13	13	14	15	15	pF
	B-port input, A-port output		3	3	3	3	4	

- (1) Power dissipation capacitance per transceiver  
(2)  $t_r$ : Rise time;  $t_f$ : Fall time

## 7.12 Typical Characteristics

### 7.12.1 Typical Propagation Delay (A to B) vs Load Capacitance, $T_A = 25^\circ\text{C}$ , $V_{CCA} = 1.8\text{ V}$

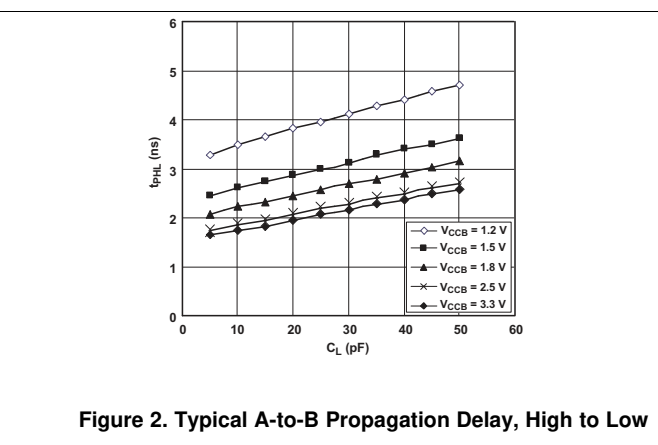
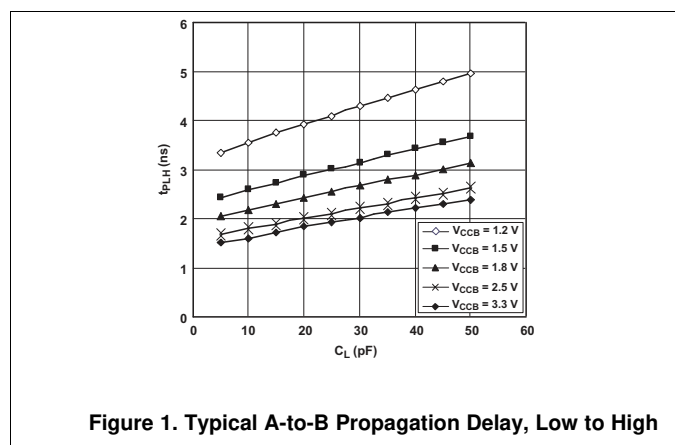

### 7.12.2 Typical Propagation Delay (A to B) vs Load Capacitance, $T_A = 25^\circ\text{C}$ , $V_{CCA} = 2.5\text{ V}$

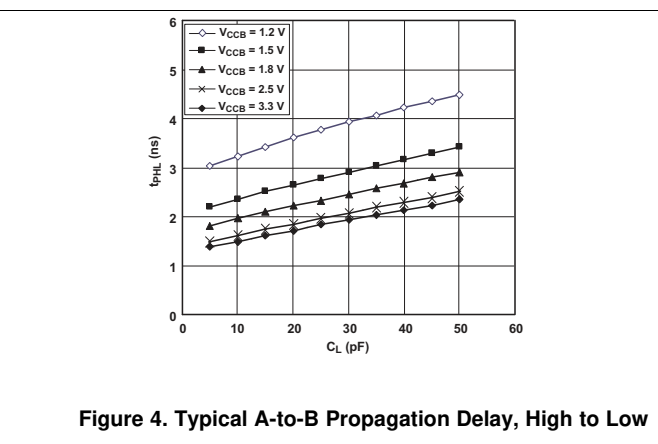
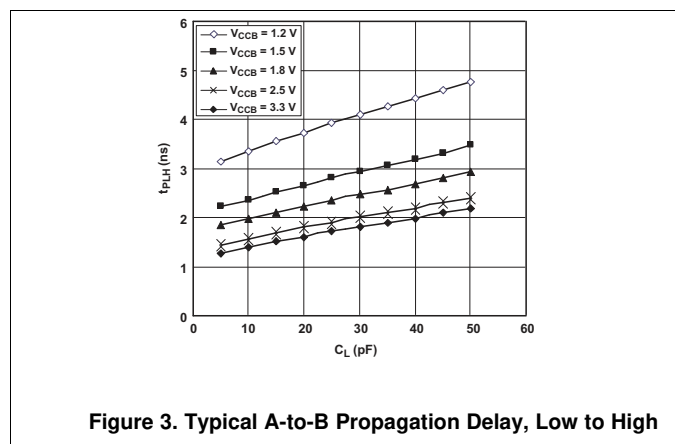

### 7.12.3 Typical Propagation Delay (A to B) vs Load Capacitance, $T_A = 25^\circ\text{C}$ , $V_{CCA} = 3.3\text{ V}$

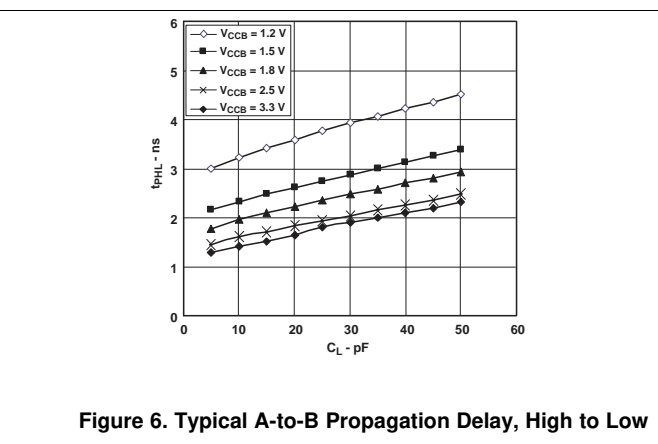
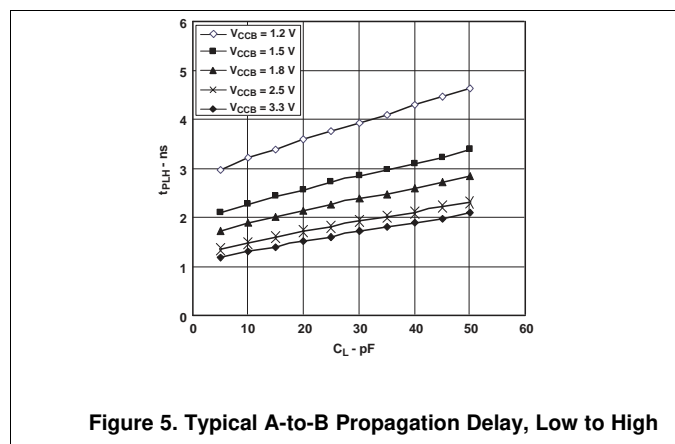

## 8 Parameter Measurement Information

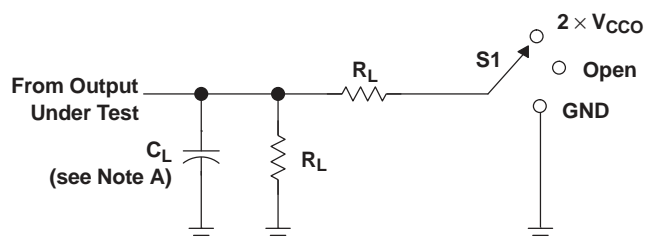

LOAD CIRCUIT

TEST	S1
$t_{pd}$	Open
$t_{PLZ}/t_{PZL}$	$2 \times V_{CCO}$
$t_{PHZ}/t_{PZH}$	GND

$V_{CCO}$	$C_L$	$R_L$	$V_{TP}$
1.2 V	15 pF	2 k $\Omega$	0.1 V
1.5 V $\pm$ 0.1 V	15 pF	2 k $\Omega$	0.1 V
1.8 V $\pm$ 0.15 V	15 pF	2 k $\Omega$	0.15 V
2.5 V $\pm$ 0.2 V	15 pF	2 k $\Omega$	0.15 V
3.3 V $\pm$ 0.3 V	15 pF	2 k $\Omega$	0.3 V

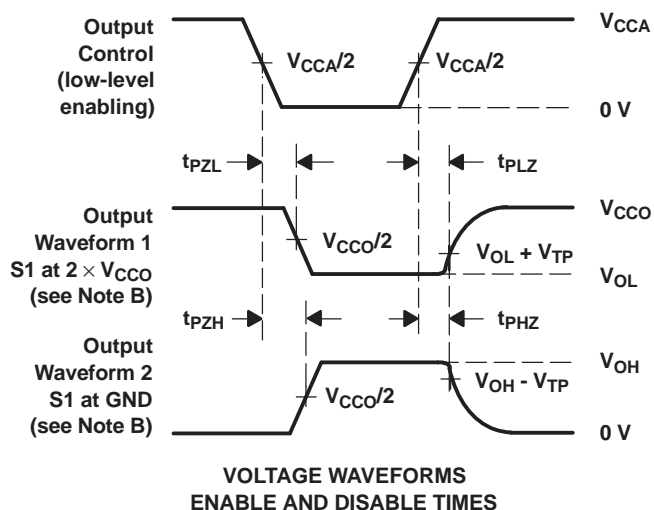
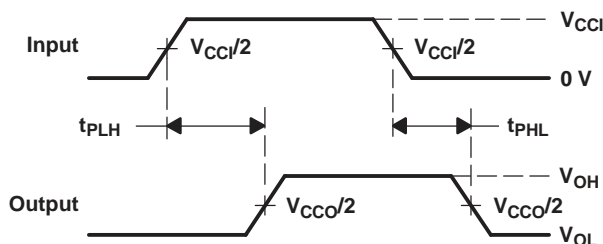
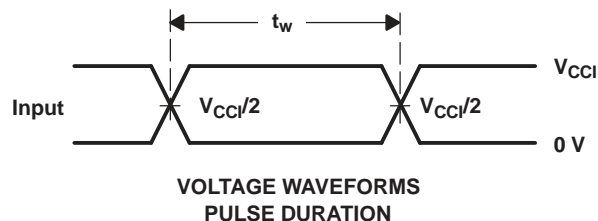

- NOTES:
- $C_L$  includes probe and jig capacitance.
  - Waveform 1 is for an output with internal conditions such that the output is low, except when disabled by the output control. Waveform 2 is for an output with internal conditions such that the output is high, except when disabled by the output control.
  - All input pulses are supplied by generators having the following characteristics:  $PRR \leq 10$  MHz,  $Z_O = 50 \Omega$ ,  $dv/dt \geq 1$  V/ns.
  - The outputs are measured one at a time, with one transition per measurement.
  - $t_{PLZ}$  and  $t_{PHZ}$  are the same as  $t_{dis}$ .
  - $t_{PZL}$  and  $t_{PZH}$  are the same as  $t_{en}$ .
  - $t_{PLH}$  and  $t_{PHL}$  are the same as  $t_{pd}$ .
  - $V_{CCI}$  is the  $V_{CC}$  associated with the input port.
  - $V_{CCO}$  is the  $V_{CC}$  associated with the output port.

Figure 7. Load Circuit and Voltage Waveforms

## 9 Detailed Description

### 9.1 Overview

This dual-bit non-inverting bus transceiver uses two separate configurable power-supply rails. The A port is designed to track  $V_{CCA}$  and accepts any supply voltage from 1.2 V to 3.6 V. The B port is designed to track  $V_{CCB}$  and accepts any supply voltage from 1.2 V to 3.6 V. This allows for universal low-voltage bidirectional translation and level-shifting between any of the 1.2 V, 1.5 V, 1.8 V, 2.5 V, and 3.3 V voltage nodes.

The SN74AVCH2T45 is designed for asynchronous communication between two data buses. The logic levels of the direction-control (DIR pin) input activate either the B-port outputs or the A-port outputs. The device transmits data from the A bus to the B bus when the B-port outputs are activated and from the B bus to the A bus when the A-port outputs are activated.

The SN74AVCH2T45 features active bus-hold circuitry.

The DIR input is powered by supply voltage from  $V_{CCA}$ .

This device is fully specified for partial-power-down applications using off output current ( $I_{off}$ ). The  $I_{off}$  circuitry disables the outputs, preventing damaging current backflow through the device when it is powered down.

The  $V_{CC}$  isolation feature ensures that if either  $V_{CC}$  input is at GND, both ports are put in a high-impedance state. This will prevent a false high or low logic being presented at the output.

NanoFree package technology is a major breakthrough in IC packaging concepts, using the die as the package.

### 9.2 Functional Block Diagram

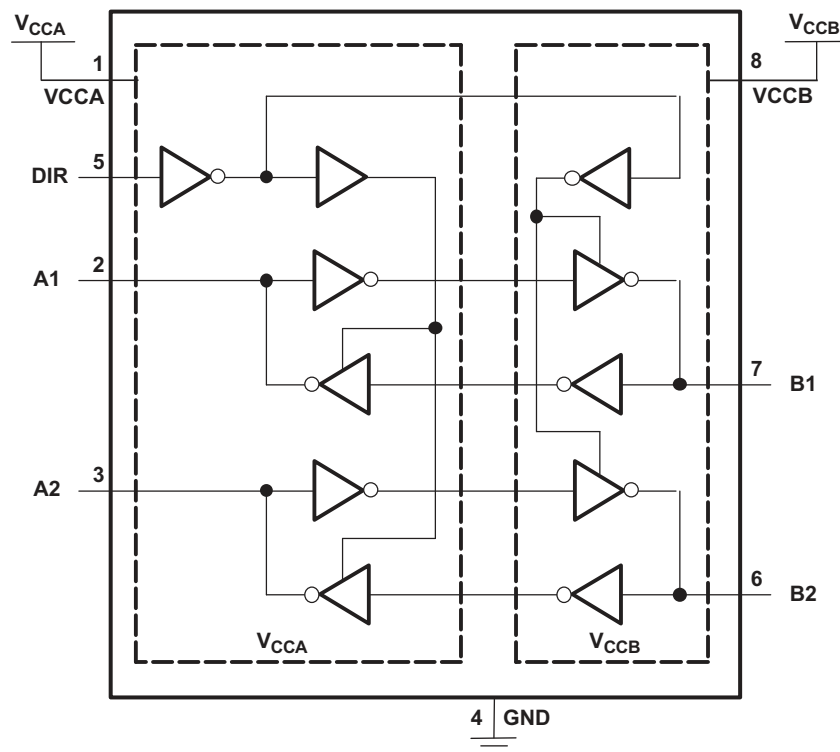

## 9.3 Feature Description

### 9.3.1 VCC Isolation

The  $V_{CC}$  isolation feature ensures that if either  $V_{CCA}$  or  $V_{CCB}$  are at GND, both ports will be in a high-impedance state ( $I_{OZ}$  shown in the [Functional Block Diagram](#)). This prevents false logic levels from being presented to either bus.

### 9.3.2 2-Rail Design

Fully configurable 2-rail design allows each port to operate over the full 1.2 V to 3.6 V power-supply range.

### 9.3.3 IO Ports are 4.6 V Tolerant

The IO ports are up to 4.6 V tolerant

### 9.3.4 Partial Power Down Mode

This device is fully specified for partial-power-down applications using off output current ( $I_{off}$ ). The  $I_{off}$  circuitry disables the outputs, preventing damaging current backflow through the device when it is powered down.

### 9.3.5 Bus Hold on Data Inputs

Active bus-hold circuitry holds unused or un-driven inputs at a valid logic state. TI does not recommend using pull-up or pull-down resistors with the bus-hold circuitry.

## 9.4 Device Functional Modes

**Table 1. Function Table (Each Transceiver)**

INPUT DIR	OPERATION
L	B data to A bus
H	A data to B bus

## 10 Application and Implementation

### NOTE

Information in the following applications sections is not part of the TI component specification, and TI does not warrant its accuracy or completeness. TI's customers are responsible for determining suitability of components for their purposes. Customers should validate and test their design implementation to confirm system functionality.

### 10.1 Application Information

The SN74AVCH2T45 is used to shift IO voltage levels from one voltage domain to another. Each bus (bus A and bus B) have independent power supplies, and a direction pin is used to control the direction of data flow.

### 10.2 Typical Applications

#### 10.2.1 Unidirectional Logic Level-Shifting Application

Figure 8 is an example of the SN74AVCH2T45 circuit used in a unidirectional logic level-shifting application.

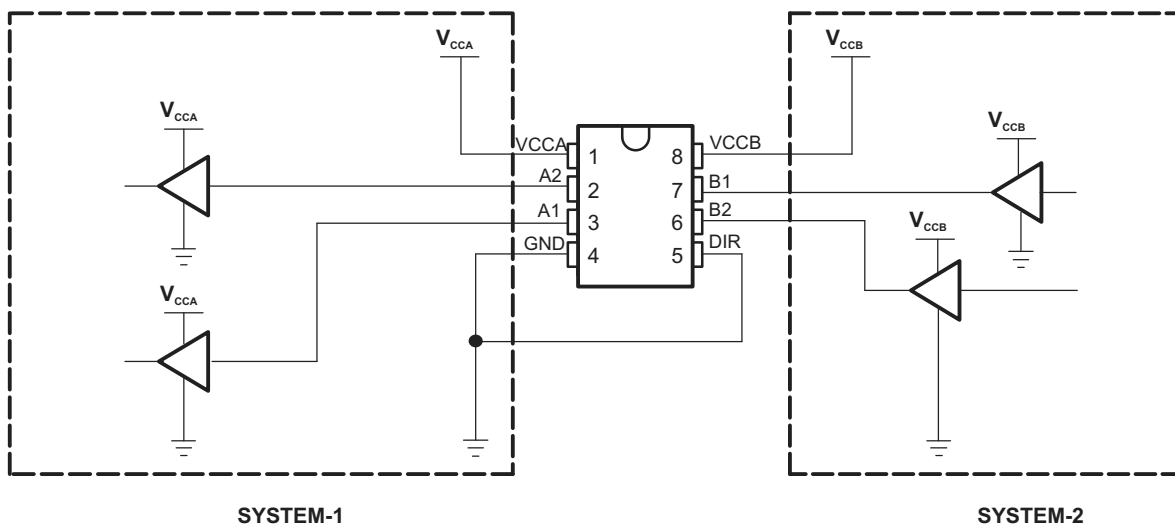

**Figure 8. Unidirectional Logic Level-Shifting Application**

##### 10.2.1.1 Design Requirements

This device uses drivers which are enabled depending on the state of the DIR pin. The designer must know the intended flow of data and take care not to violate any of the high or low logic levels. Active bus-hold circuitry holds unused or un-driven inputs at a valid logic state. TI does not recommend using pull-up or pull-down resistors with the bus-hold circuitry.

##### 10.2.1.2 Detailed Design Procedure

Table 2 lists the pins and pin descriptions of the SN74AVCH2T45 connections with SYSTEM-1 and SYSTEM-2.



**Typical Applications (continued)**

**Table 2. SN74AVCH2T45 Pin Connections With SYSTEM-1 and SYSTEM-2**

PIN	NAME	DESCRIPTION
1	VCCA	SYSTEM-1 supply voltage (1.2 V to 3.6 V)
2	A1	Output level depends on V <sub>CCA</sub> .
3	A2	Output level depends on V <sub>CCA</sub> .
4	GND	Device GND
5	DIR	The GND (low-level) determines B-port to A-port direction.
6	B2	Input threshold value depends on V <sub>CCB</sub> .
7	B1	Input threshold value depends on V <sub>CCB</sub> .
8	VCCB	SYSTEM-2 supply voltage (1.2 V to 3.6 V)

**10.2.1.3 Application Curve**

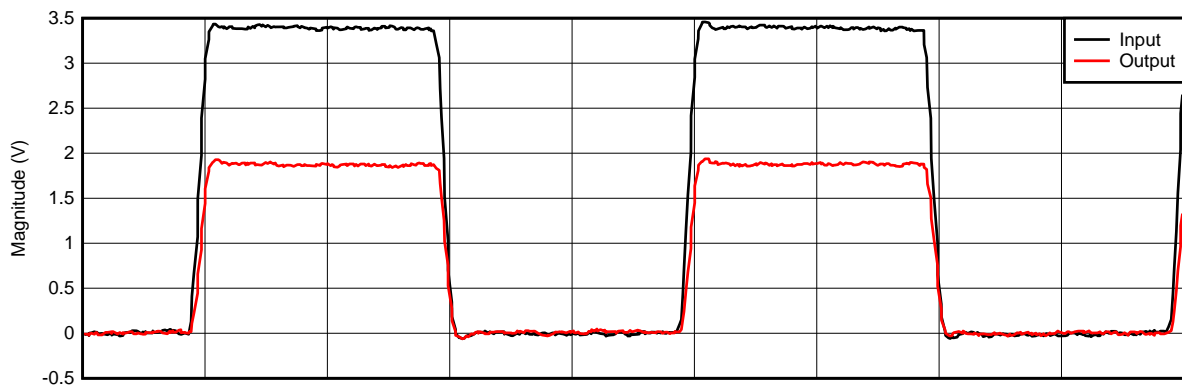

D002

**Figure 9. 3.3- to 1.8-V Level-Shifting With 1-MHz Square Wave**

### 10.2.2 Bidirectional Logic Level-Shifting Application

Figure 10 shows the SN74AVCH2T45 used in a bidirectional logic level-shifting application. Because the SN74AVCH2T45 does not have an output-enable (OE) pin, system designers should take precautions to avoid bus contention between SYSTEM-1 and SYSTEM-2 when changing directions.

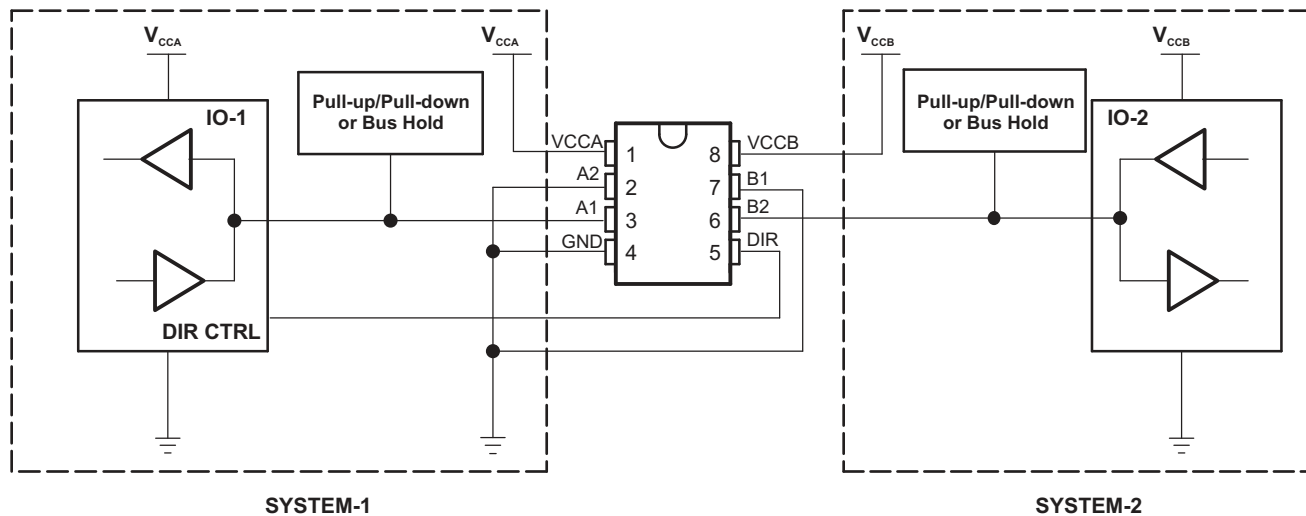

Figure 10. Bidirectional Logic Level-Shifting Application

#### 10.2.2.1 Design Requirements

This device uses drivers which are enabled depending on the state of the DIR pin. The designer must know the intended flow of data and take care not to violate any of the high or low logic levels. Active bus-hold circuitry holds unused or un-driven inputs at a valid logic state. TI does not recommend using pull-up or pull-down resistors with the bus-hold circuitry.

#### 10.2.2.2 Detailed Design Procedure

Table 3 lists a sequence that shows data transmission from SYSTEM-1 to SYSTEM-2 and then from SYSTEM-2 to SYSTEM-1.

Table 3. Data Transmission Sequence

STATE	DIR CTRL	IO-1	IO-2	DESCRIPTION
1	H	Output	Input	SYSTEM-1 data to SYSTEM-2
2	H	Hi-Z	Hi-Z	SYSTEM-2 is getting ready to send data to SYSTEM-1. IO-1 and IO-2 are disabled. The bus-line state depends on pull-up or pull-down. <sup>(1)</sup>
3	L	Hi-Z	Hi-Z	DIR bit is flipped. IO-1 and IO-2 still are disabled. The bus-line state depends on pull-up or pull-down. <sup>(1)</sup>
4	L	Input	Output	SYSTEM-2 data to SYSTEM-1

(1) SYSTEM-1 and SYSTEM-2 must use the same conditions, i.e., both pullup or both pulldown.

### 10.2.2.2.1 Enable Times

Calculate the enable times for the SN74AVCH2T45 using the following formulas:

$$t_{PZH} \text{ (DIR to A)} = t_{PLZ} \text{ (DIR to B)} + t_{PLH} \text{ (B to A)} \quad (1)$$

$$t_{PZL} \text{ (DIR to A)} = t_{PHZ} \text{ (DIR to B)} + t_{PHL} \text{ (B to A)} \quad (2)$$

$$t_{PZH} \text{ (DIR to B)} = t_{PLZ} \text{ (DIR to A)} + t_{PLH} \text{ (A to B)} \quad (3)$$

$$t_{PZL} \text{ (DIR to B)} = t_{PHZ} \text{ (DIR to A)} + t_{PHL} \text{ (A to B)} \quad (4)$$

In a bidirectional application, these enable times provide the maximum delay from the time the DIR bit is switched until an output is expected. For example, if the SN74AVCH2T45 initially is transmitting from A to B, the DIR bit is switched; the B port of the device must be disabled before presenting it with an input. After the B port has been disabled, an input signal applied to it appears on the corresponding A port after the specified propagation delay.

### 10.2.2.3 Application Curve

Refer to [Figure 9](#).

## 11 Power Supply Recommendations

A proper power-up sequence always should be followed to avoid excessive supply current, bus contention, oscillations, or other anomalies. To guard against such power-up problems, take the following precautions:

1. Connect ground before any supply voltage is applied.
2. Power up  $V_{CCA}$ .
3.  $V_{CCB}$  can be ramped up along with or after  $V_{CCA}$ .

**Table 4. Typical Total Static Power Consumption ( $I_{CCA} + I_{CCB}$ )**

$V_{CCB}$	$V_{CCA}$						UNIT
	0 V	1.2 V	1.5 V	1.8 V	2.5 V	3.3 V	
0 V	0	< 0.5	< 0.5	< 0.5	< 0.5	< 0.5	μA
1.2 V	< 0.5	< 1	< 1	< 1	< 1	1	
1.5 V	< 0.5	< 1	< 1	< 1	< 1	1	
1.8 V	< 0.5	< 1	< 1	< 1	< 1	< 1	
2.5 V	< 0.5	1	< 1	< 1	< 1	< 1	
3.3 V	< 0.5	1	< 1	< 1	< 1	< 1	

## 12 Layout

### 12.1 Layout Guidelines

To ensure reliability of the device, following common printed-circuit board layout guidelines is recommended.

- Bypass capacitors should be used on power supplies. Place the capacitors as close as possible to the  $V_{CCA}$ ,  $V_{CCB}$  pin and GND pin.
- Short trace lengths should be used to avoid excessive loading.

### 12.2 Layout Example

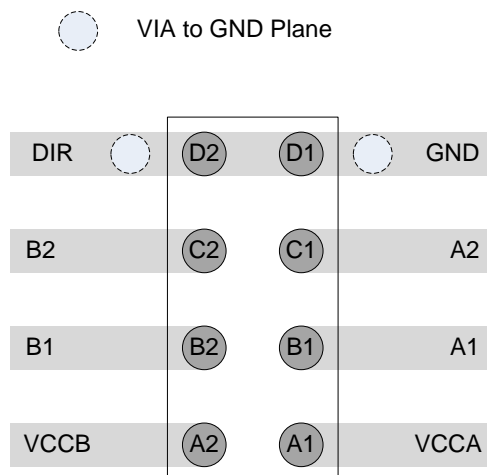

**Figure 11. Layout Example for YZP Package**

## 13 Device and Documentation Support

### 13.1 Documentation Support

#### 13.1.1 Related Documentation

For related documentation see the following:

- *Implications of Slow or Floating CMOS Inputs*, [SCBA004](#)

### 13.2 Trademarks

NanoFree is a trademark of Texas Instruments.

All other trademarks are the property of their respective owners.

### 13.3 Electrostatic Discharge Caution



These devices have limited built-in ESD protection. The leads should be shorted together or the device placed in conductive foam during storage or handling to prevent electrostatic damage to the MOS gates.

### 13.4 Glossary

[SLYZ022](#) — *TI Glossary*.

This glossary lists and explains terms, acronyms, and definitions.

## 14 Mechanical, Packaging, and Orderable Information

The following pages include mechanical, packaging, and orderable information. This information is the most current data available for the designated devices. This data is subject to change without notice and revision of this document. For browser-based versions of this data sheet, refer to the left-hand navigation.

**PACKAGING INFORMATION**

Orderable Device	Status (1)	Package Type	Package Drawing	Pins	Package Qty	Eco Plan (2)	Lead finish/ Ball material (6)	MSL Peak Temp (3)	Op Temp (°C)	Device Marking (4/5)	Samples
74AVCH2T45DCTTE4	ACTIVE	SM8	DCT	8	250	RoHS & Green	NIPDAU	Level-1-260C-UNLIM	-40 to 85	ET2 Z	<a href="#">Samples</a>
SN74AVCH2T45DCTR	ACTIVE	SM8	DCT	8	3000	RoHS & Green	NIPDAU	Level-1-260C-UNLIM	-40 to 85	ET2 Z	<a href="#">Samples</a>
SN74AVCH2T45DCTT	ACTIVE	SM8	DCT	8	250	RoHS & Green	NIPDAU	Level-1-260C-UNLIM	-40 to 85	ET2 Z	<a href="#">Samples</a>
SN74AVCH2T45DCUR	ACTIVE	VSSOP	DCU	8	3000	RoHS & Green	NIPDAU   SN	Level-1-260C-UNLIM	-40 to 85	(ET2R, T2) EZ	<a href="#">Samples</a>
SN74AVCH2T45DCURG4	ACTIVE	VSSOP	DCU	8	3000	RoHS & Green	NIPDAU	Level-1-260C-UNLIM	-40 to 85	ET2R	<a href="#">Samples</a>
SN74AVCH2T45DCUT	ACTIVE	VSSOP	DCU	8	250	RoHS & Green	NIPDAU   SN	Level-1-260C-UNLIM	-40 to 85	(ET2R, T2) EZ	<a href="#">Samples</a>
SN74AVCH2T45YZPR	ACTIVE	DSBGA	YZP	8	3000	RoHS & Green	SNAGCU	Level-1-260C-UNLIM	-40 to 85	TFN	<a href="#">Samples</a>

(1) The marketing status values are defined as follows:

**ACTIVE:** Product device recommended for new designs.

**LIFEBUY:** TI has announced that the device will be discontinued, and a lifetime-buy period is in effect.

**NRND:** Not recommended for new designs. Device is in production to support existing customers, but TI does not recommend using this part in a new design.

**PREVIEW:** Device has been announced but is not in production. Samples may or may not be available.

**OBSELETE:** TI has discontinued the production of the device.

(2) **RoHS:** TI defines "RoHS" to mean semiconductor products that are compliant with the current EU RoHS requirements for all 10 RoHS substances, including the requirement that RoHS substance do not exceed 0.1% by weight in homogeneous materials. Where designed to be soldered at high temperatures, "RoHS" products are suitable for use in specified lead-free processes. TI may reference these types of products as "Pb-Free".

**RoHS Exempt:** TI defines "RoHS Exempt" to mean products that contain lead but are compliant with EU RoHS pursuant to a specific EU RoHS exemption.

**Green:** TI defines "Green" to mean the content of Chlorine (Cl) and Bromine (Br) based flame retardants meet JS709B low halogen requirements of <=1000ppm threshold. Antimony trioxide based flame retardants must also meet the <=1000ppm threshold requirement.

(3) MSL, Peak Temp. - The Moisture Sensitivity Level rating according to the JEDEC industry standard classifications, and peak solder temperature.

(4) There may be additional marking, which relates to the logo, the lot trace code information, or the environmental category on the device.

(5) Multiple Device Markings will be inside parentheses. Only one Device Marking contained in parentheses and separated by a "~" will appear on a device. If a line is indented then it is a continuation of the previous line and the two combined represent the entire Device Marking for that device.

<sup>(6)</sup> Lead finish/Ball material - Orderable Devices may have multiple material finish options. Finish options are separated by a vertical ruled line. Lead finish/Ball material values may wrap to two lines if the finish value exceeds the maximum column width.

**Important Information and Disclaimer:** The information provided on this page represents TI's knowledge and belief as of the date that it is provided. TI bases its knowledge and belief on information provided by third parties, and makes no representation or warranty as to the accuracy of such information. Efforts are underway to better integrate information from third parties. TI has taken and continues to take reasonable steps to provide representative and accurate information but may not have conducted destructive testing or chemical analysis on incoming materials and chemicals. TI and TI suppliers consider certain information to be proprietary, and thus CAS numbers and other limited information may not be available for release.

In no event shall TI's liability arising out of such information exceed the total purchase price of the TI part(s) at issue in this document sold by TI to Customer on an annual basis.

**TAPE AND REEL INFORMATION**

**QUADRANT ASSIGNMENTS FOR PIN 1 ORIENTATION IN TAPE**

\*All dimensions are nominal

Device	Package Type	Package Drawing	Pins	SPQ	Reel Diameter (mm)	Reel Width W1 (mm)	A0 (mm)	B0 (mm)	K0 (mm)	P1 (mm)	W (mm)	Pin1 Quadrant
SN74AVCH2T45DCTR	SM8	DCT	8	3000	180.0	13.0	3.35	4.5	1.55	4.0	12.0	Q3
SN74AVCH2T45DCTT	SM8	DCT	8	250	180.0	13.0	3.35	4.5	1.55	4.0	12.0	Q3
SN74AVCH2T45DCUR	VSSOP	DCU	8	3000	180.0	9.0	2.25	3.4	1.0	4.0	8.0	Q3
SN74AVCH2T45DCUR	VSSOP	DCU	8	3000	180.0	8.4	2.25	3.35	1.05	4.0	8.0	Q3
SN74AVCH2T45DCURG4	VSSOP	DCU	8	3000	180.0	8.4	2.25	3.35	1.05	4.0	8.0	Q3
SN74AVCH2T45YZPR	DSBGA	YZP	8	3000	178.0	9.2	1.02	2.02	0.63	4.0	8.0	Q1



**TAPE AND REEL BOX DIMENSIONS**

\*All dimensions are nominal

Device	Package Type	Package Drawing	Pins	SPQ	Length (mm)	Width (mm)	Height (mm)
SN74AVCH2T45DCTR	SM8	DCT	8	3000	182.0	182.0	20.0
SN74AVCH2T45DCTT	SM8	DCT	8	250	182.0	182.0	20.0
SN74AVCH2T45DCUR	VSSOP	DCU	8	3000	182.0	182.0	20.0
SN74AVCH2T45DCUR	VSSOP	DCU	8	3000	202.0	201.0	28.0
SN74AVCH2T45DCURG4	VSSOP	DCU	8	3000	202.0	201.0	28.0
SN74AVCH2T45YZPR	DSBGA	YZP	8	3000	220.0	220.0	35.0

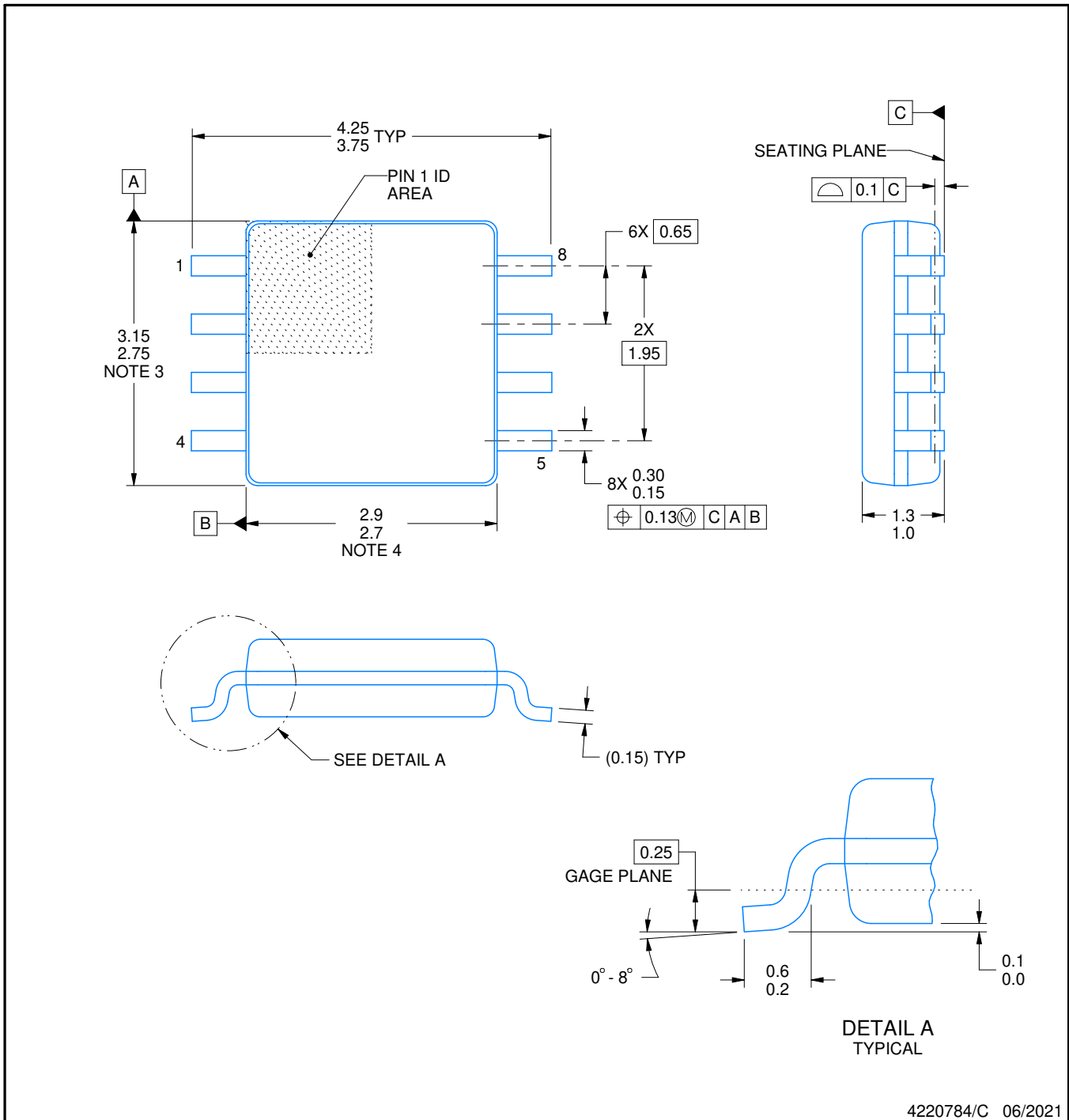
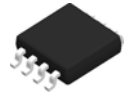

4220784/C 06/2021

NOTES:

1. All linear dimensions are in millimeters. Dimensions in parenthesis are for reference only. Dimensioning and tolerancing per ASME Y14.5M.
2. This drawing is subject to change without notice.
3. This dimension does not include mold flash, protrusions, or gate burrs. Mold flash, protrusions, or gate burrs shall not exceed 0.15 mm per side.
4. This dimension does not include interlead flash. Interlead flash shall not exceed 0.25 mm per side.

# EXAMPLE BOARD LAYOUT

DCT0008A

SSOP - 1.3 mm max height

SMALL OUTLINE PACKAGE

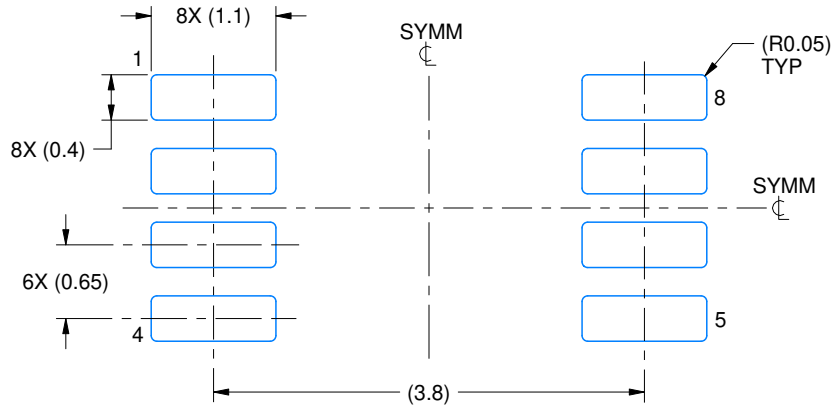

LAND PATTERN EXAMPLE  
EXPOSED METAL SHOWN  
SCALE:15X

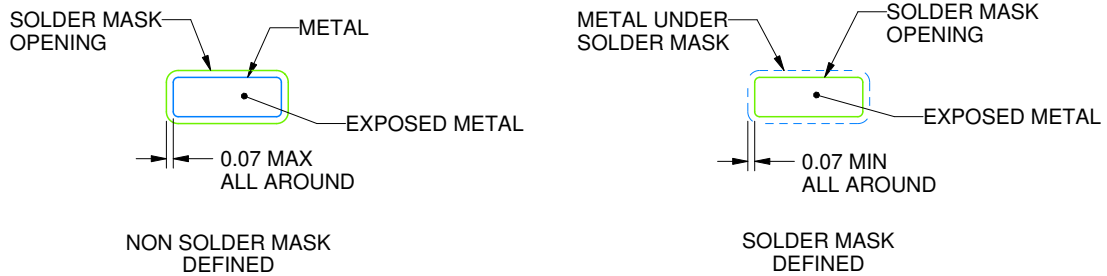

SOLDER MASK DETAILS

4220784/C 06/2021

NOTES: (continued)

- 5. Publication IPC-7351 may have alternate designs.
- 6. Solder mask tolerances between and around signal pads can vary based on board fabrication site.

# EXAMPLE STENCIL DESIGN

DCT0008A

SSOP - 1.3 mm max height

SMALL OUTLINE PACKAGE

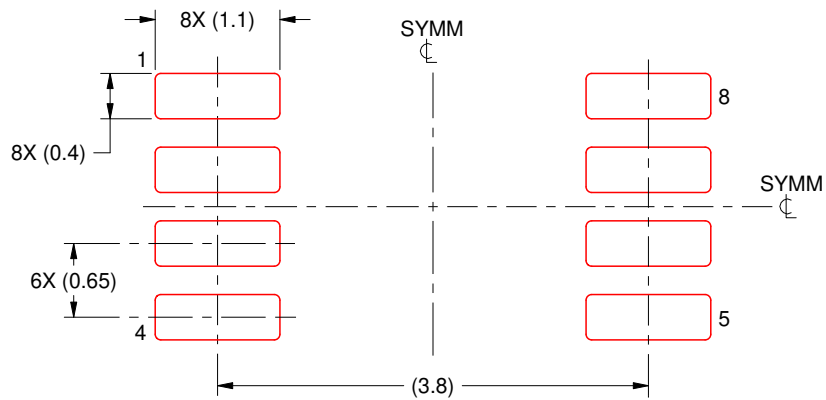

SOLDER PASTE EXAMPLE  
BASED ON 0.125 mm THICK STENCIL  
SCALE:15X

4220784/C 06/2021

NOTES: (continued)

7. Laser cutting apertures with trapezoidal walls and rounded corners may offer better paste release. IPC-7525 may have alternate design recommendations.
8. Board assembly site may have different recommendations for stencil design.

YZP0008



# PACKAGE OUTLINE

DSBGA - 0.5 mm max height

DIE SIZE BALL GRID ARRAY

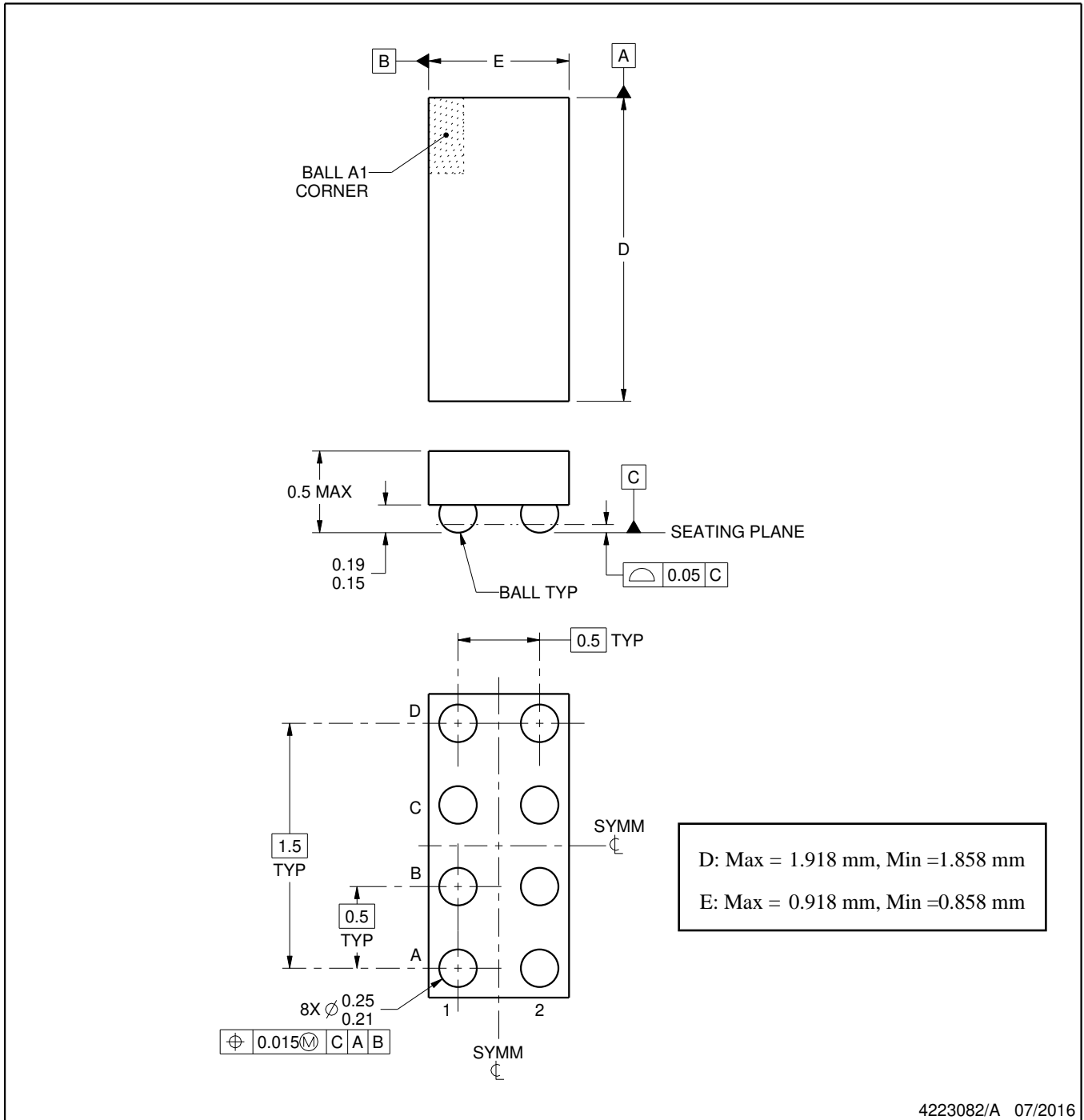

NOTES:

- 1. All linear dimensions are in millimeters. Any dimensions in parenthesis are for reference only. Dimensioning and tolerancing per ASME Y14.5M.
- 2. This drawing is subject to change without notice.

# EXAMPLE BOARD LAYOUT

YZP0008

DSBGA - 0.5 mm max height

DIE SIZE BALL GRID ARRAY

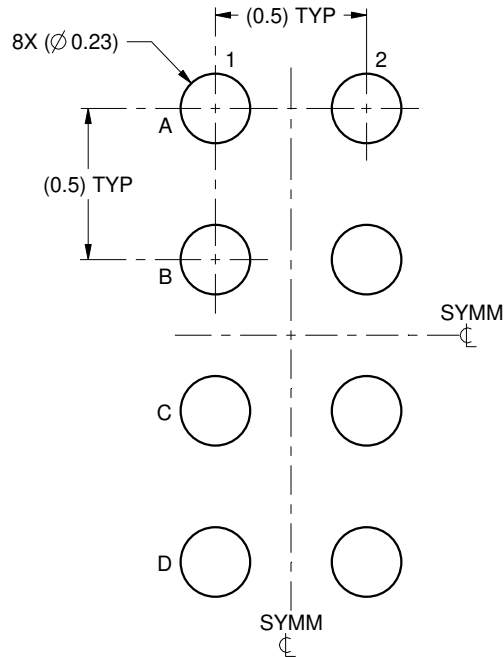

LAND PATTERN EXAMPLE  
SCALE:40X

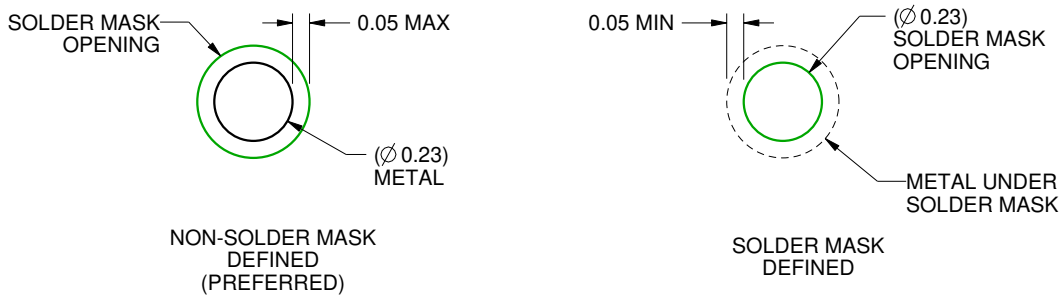

SOLDER MASK DETAILS  
NOT TO SCALE

4223082/A 07/2016

NOTES: (continued)

3. Final dimensions may vary due to manufacturing tolerance considerations and also routing constraints. For more information, see Texas Instruments literature number SNVA009 ([www.ti.com/lit/snva009](http://www.ti.com/lit/snva009)).

# EXAMPLE STENCIL DESIGN

YZP0008

DSBGA - 0.5 mm max height

DIE SIZE BALL GRID ARRAY

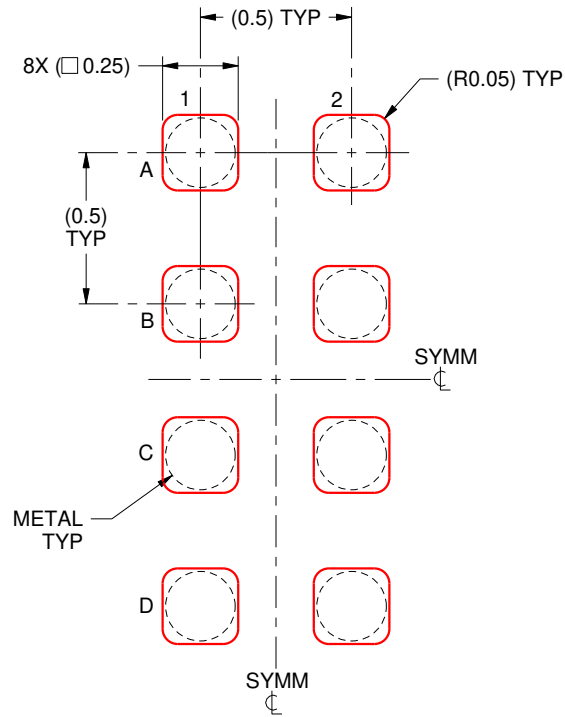

SOLDER PASTE EXAMPLE  
BASED ON 0.1 mm THICK STENCIL  
SCALE:40X

4223082/A 07/2016

NOTES: (continued)

4. Laser cutting apertures with trapezoidal walls and rounded corners may offer better paste release.

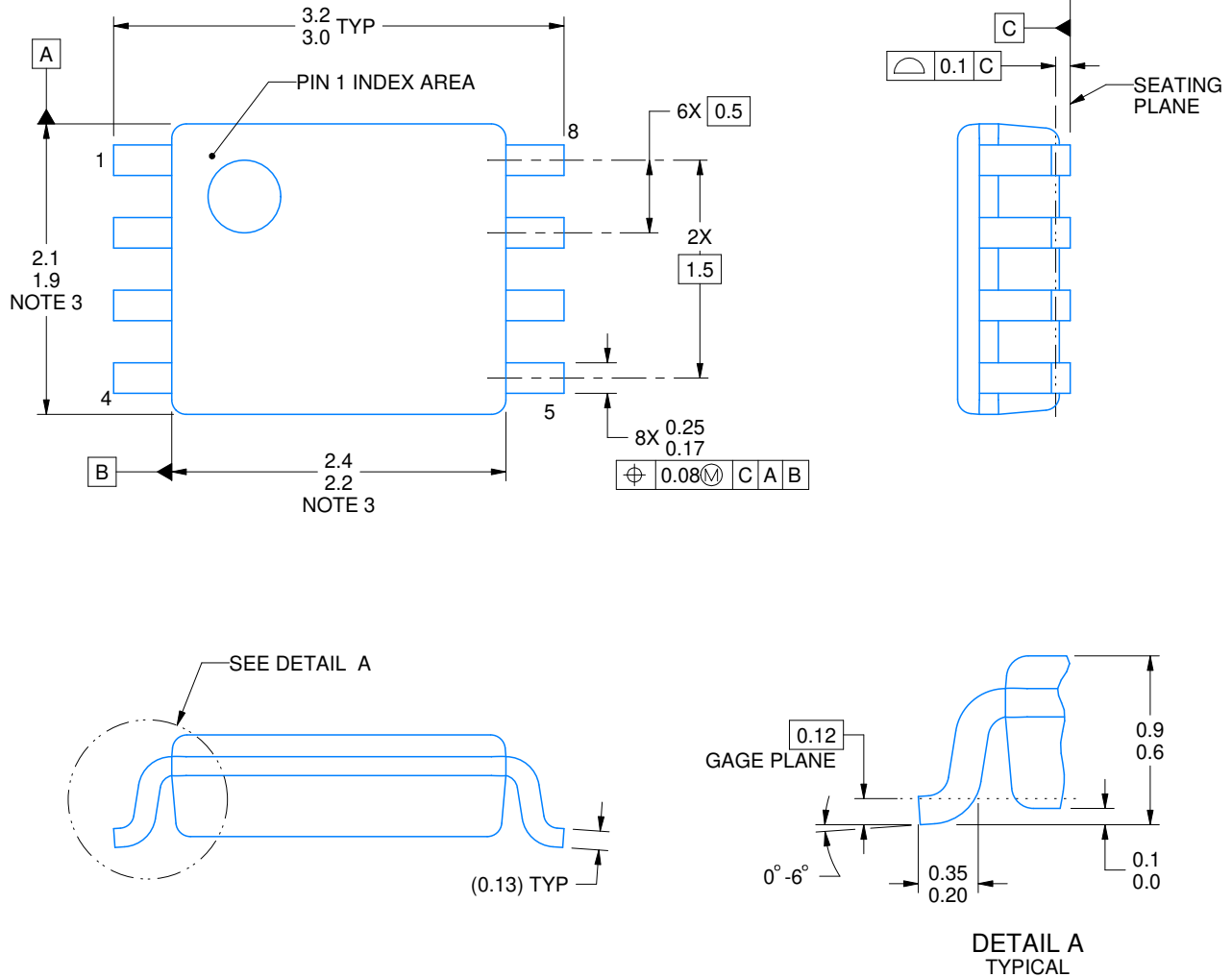

4225266/A 09/2014

NOTES:

1. All linear dimensions are in millimeters. Any dimensions in parenthesis are for reference only. Dimensioning and tolerancing per ASME Y14.5M.
2. This drawing is subject to change without notice.
3. This dimension does not include mold flash, protrusions, or gate burrs. Mold flash, protrusions, or gate burrs shall not exceed 0.15 mm per side.
4. Reference JEDEC registration MO-187 variation CA.



# EXAMPLE BOARD LAYOUT

DCU0008A

VSSOP - 0.9 mm max height

SMALL OUTLINE PACKAGE

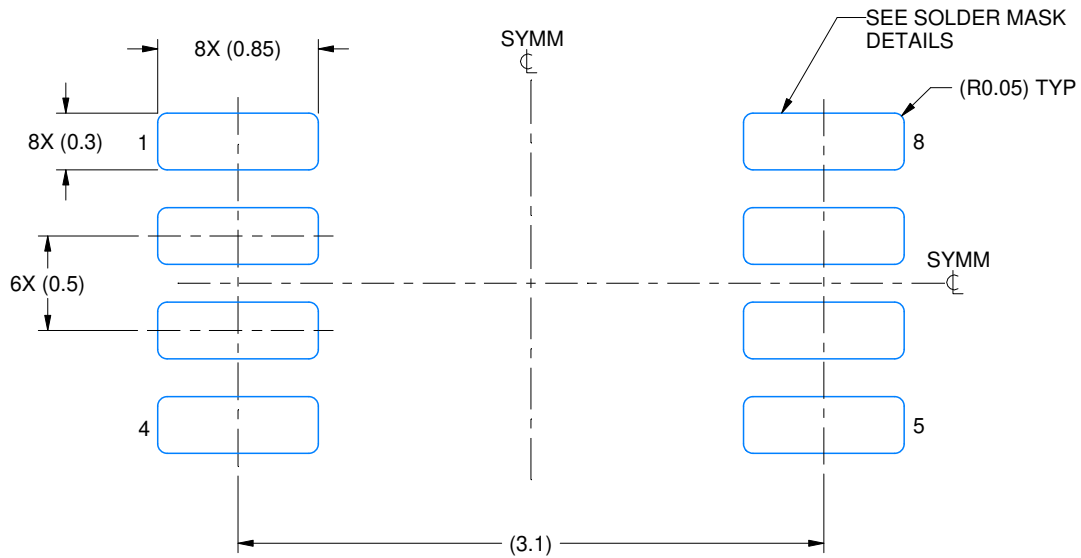

LAND PATTERN EXAMPLE  
EXPOSED METAL SHOWN  
SCALE: 25X

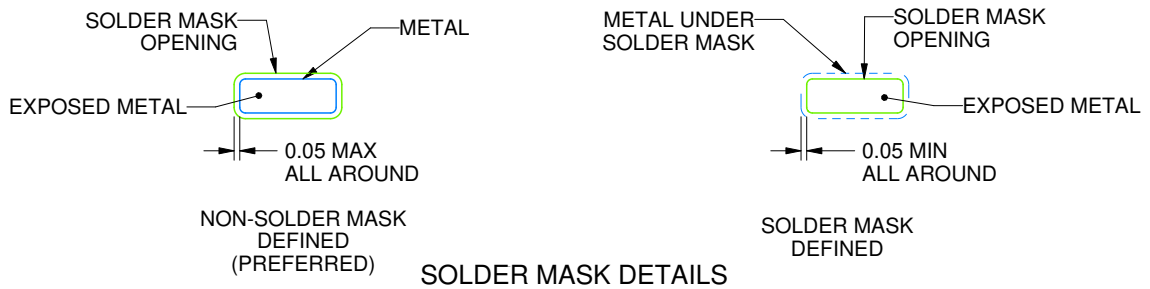

4225266/A 09/2014

NOTES: (continued)

- 5. Publication IPC-7351 may have alternate designs.
- 6. Solder mask tolerances between and around signal pads can vary based on board fabrication site.

# EXAMPLE STENCIL DESIGN

DCU0008A

VSSOP - 0.9 mm max height

SMALL OUTLINE PACKAGE

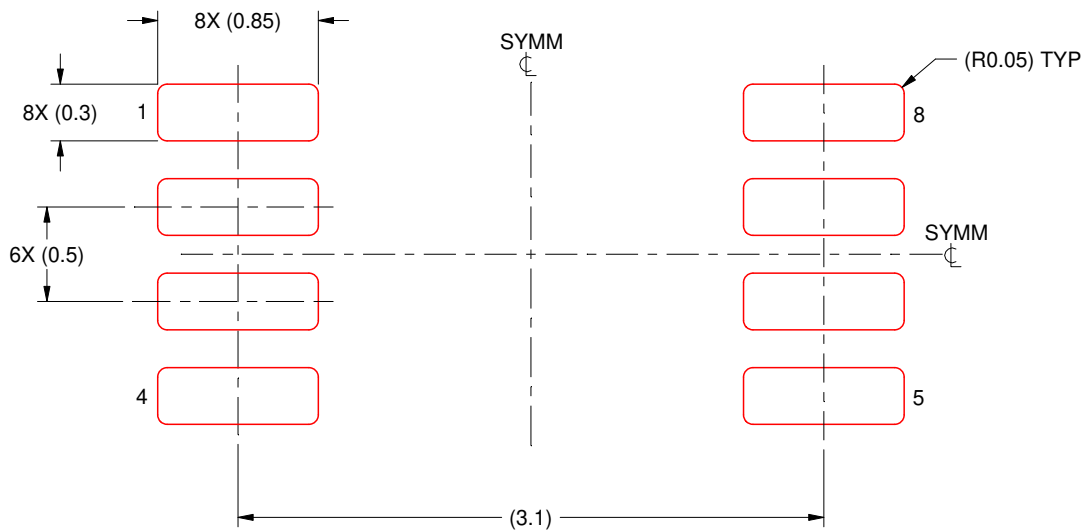

SOLDER PASTE EXAMPLE  
BASED ON 0.125 mm THICK STENCIL  
SCALE: 25X

4225266/A 09/2014

NOTES: (continued)

7. Laser cutting apertures with trapezoidal walls and rounded corners may offer better paste release. IPC-7525 may have alternate design recommendations.
8. Board assembly site may have different recommendations for stencil design.

## IMPORTANT NOTICE AND DISCLAIMER

TI PROVIDES TECHNICAL AND RELIABILITY DATA (INCLUDING DATA SHEETS), DESIGN RESOURCES (INCLUDING REFERENCE DESIGNS), APPLICATION OR OTHER DESIGN ADVICE, WEB TOOLS, SAFETY INFORMATION, AND OTHER RESOURCES "AS IS" AND WITH ALL FAULTS, AND DISCLAIMS ALL WARRANTIES, EXPRESS AND IMPLIED, INCLUDING WITHOUT LIMITATION ANY IMPLIED WARRANTIES OF MERCHANTABILITY, FITNESS FOR A PARTICULAR PURPOSE OR NON-INFRINGEMENT OF THIRD PARTY INTELLECTUAL PROPERTY RIGHTS.

These resources are intended for skilled developers designing with TI products. You are solely responsible for (1) selecting the appropriate TI products for your application, (2) designing, validating and testing your application, and (3) ensuring your application meets applicable standards, and any other safety, security, regulatory or other requirements.

These resources are subject to change without notice. TI grants you permission to use these resources only for development of an application that uses the TI products described in the resource. Other reproduction and display of these resources is prohibited. No license is granted to any other TI intellectual property right or to any third party intellectual property right. TI disclaims responsibility for, and you will fully indemnify TI and its representatives against, any claims, damages, costs, losses, and liabilities arising out of your use of these resources.

TI's products are provided subject to [TI's Terms of Sale](#) or other applicable terms available either on [ti.com](https://www.ti.com) or provided in conjunction with such TI products. TI's provision of these resources does not expand or otherwise alter TI's applicable warranties or warranty disclaimers for TI products.

TI objects to and rejects any additional or different terms you may have proposed.

Mailing Address: Texas Instruments, Post Office Box 655303, Dallas, Texas 75265  
Copyright © 2023, Texas Instruments Incorporated