

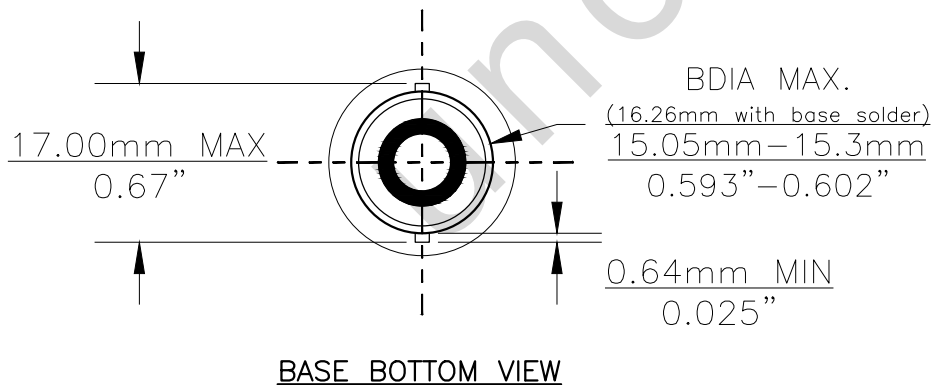

PART NO.	BASE TYPE	DESIGN VOLTS	DESIGN AMPS	MSCD	FILAMENT TYPE	AVERAGE LIFE HOURS	REVISIONS			
							REV #	DESCRIPTION	DATE	APPROVED
81	S.C. BAYONET (BA15s)	6.5V	1.02 ±8%	6 ±15%	C-6	500	1	ISSUED	11/03/2014	R.M.
							2	UPDATED FILAMENT FROM C-2R TO C-6	06/03/2015	R.M.

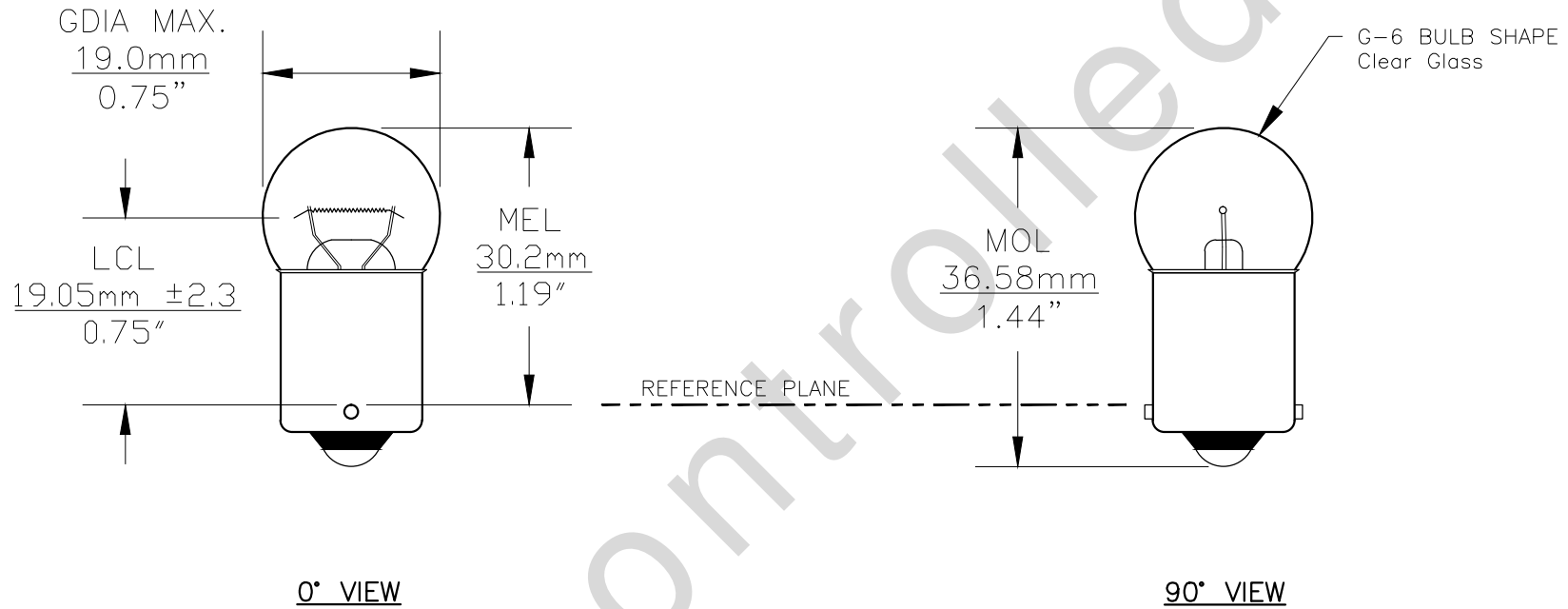

Note: Made according to SAE specifications

UNLESS OTHERWISE SPECIFIED: DIMENSIONS ARE IN INCHES TOLERANCES		CEC INDUSTRIES LTD			
DECIMALS .XX ± .05	ANGULAR .XXX ± .010	599 BOND STREET		LINDOLNSHIRE, IL 60069	
FRACTIONAL ±1/64		TITLE LIGHT BULB NO. 81			
DRAWN ROSE MEDINA	DATE 11/03/2014	SIZE A	FSCM NO.	DWG NO. 81	REV 2
CHECKED		SCALE	PLOT SCALE	SHEET 1 OF 1	
MATERIAL	FILE 81.pdf	DRAWING NOT TO SCALE			