

**FEATURES**

- 166-MHz ARM920T Processor
  - 16-kbyte Instruction Cache
  - 16-kbyte Data Cache
  - Linux®, Microsoft® Windows® CE, enabled MMU
  - 66-MHz System Bus
- MaverickKey™ IDs
  - 32-bit unique ID can be used for DRM-compliant, 128-bit random ID.
- Integrated Peripheral Interfaces
  - 16-bit SDRAM Interface (up to 4 banks)
  - 16-bit SRAM / FLASH / ROM
  - Serial EEPROM Interface
  - 1/10/100 Mbps Ethernet MAC
  - Two UARTs
  - Two-port USB 2.0 Full-speed Host (OHCI) (12 Mbits per second)
  - IrDA Interface
  - ADC
  - Serial Peripheral Interface (SPI) Port
  - 6-channel Serial Audio Interface (I<sup>2</sup>S)
  - 2-channel Low-cost Serial Audio Interface (AC'97)

**Entry-level ARM9  
System-on-chip Processor**

- Internal Peripherals
  - 12 Direct Memory Access (DMA) Channels
  - Real-time Clock with software Trim
  - Dual PLL controls all clock domains.
  - Watchdog Timer
  - Two General-purpose 16-bit Timers
  - One General-purpose 32-bit Timer
  - One 40-bit Debug Timer
  - Interrupt Controller
  - Boot ROM
- Package
  - 208-pin LQFP

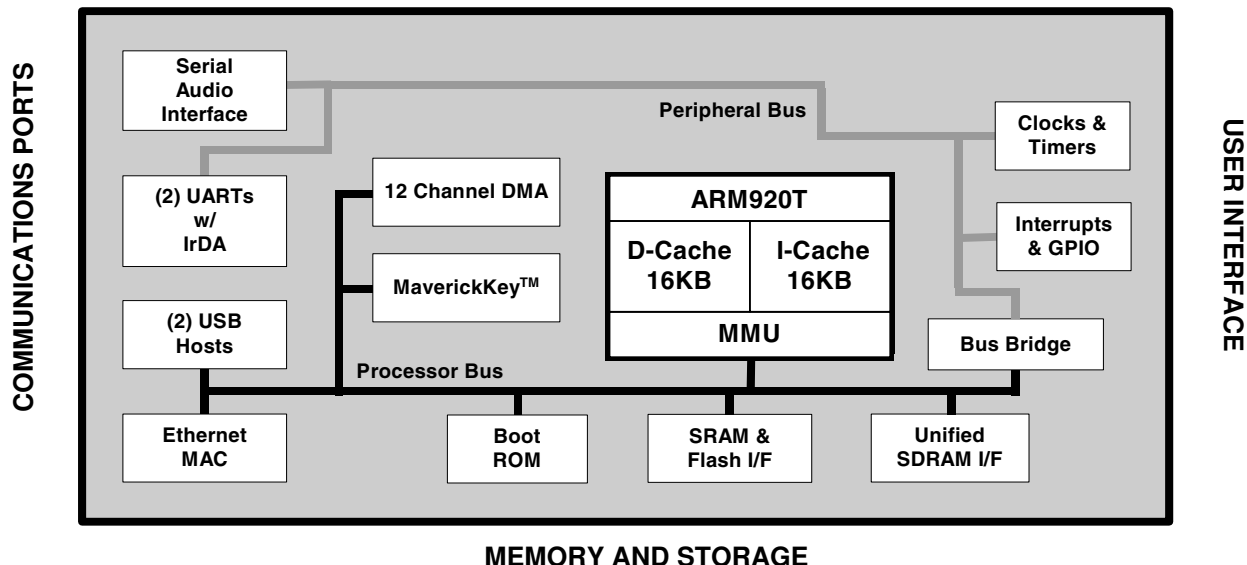

## OVERVIEW

The EP9301 is an ARM920T-based system-on-a-chip design with a large peripheral set targeted to a variety of applications:

- Industrial controls
- Digital media servers
- Integrated home media gateways
- Digital audio jukeboxes
- Streaming audio players
- Set-top boxes
- Point-of-sale terminals
- Thin clients
- Biometric security systems
- GPS & fleet management systems
- Educational toys
- Industrial computers
- Industrial hand-held devices
- Voting machines
- Medical equipment

The EP9301 is one of a series of ARM920T-based devices. Other members of the family have different peripheral sets, a coprocessor, and different package configurations.

The ARM920T microprocessor core has a separate 16-kbyte, 64-way set-associative instruction and data caches.

The MaverickKey™ unique hardware programmed IDs are a solution to the growing concern over secure web content and commerce. With Internet security playing an important role in the delivery of digital media such as books or music, traditional software methods are quickly becoming unreliable. The MaverickKey unique IDs provide OEMs with a method of utilizing specific hardware IDs such as those assigned for SDMI (Secure Digital Music Initiative) or any other authentication mechanism.

A high-performance 1/10/100 Mbps Ethernet media access controller (EMAC) is included along with external interfaces to SPI, AC'97 and I<sup>2</sup>S audio. A two-port USB 2.0 Full-speed Host (OHCI) (12 Mbits per second), two UARTs, and a analog voltage measurement analog-to-digital converter (ADC) are included as well.

The EP9301 is a high-performance, low-power RISC-based, single-chip computer built around an ARM920T microprocessor core with a maximum operating clock rate of 166 MHz. The ARM core operates from a 1.8 V supply, while the I/O operates at 3.3 V with power usage between 100 mW and 675 mW.

Table A. Change History

Revision	Date	Changes
1	October 2003	Initial Release.
2	February 2004	Update timing specifications.
3	July 2004	Update AC data.
4	July 2004	Add ADC data.
5	March 2005	Update with most-current characterization data.
F1	February 2010	Removed "Preliminary Data" statement from legal disclaimer. Removed lead-containing device part numbers. Increased minimum CVDD & VDD_PLL voltages from 1.65 V min. to 1.71 V min. Changed operating temperatures to 0 to 60°C commercial, -40 to 70°C industrial.
F2	March 2010	Increased commercial/industrial temperatures to 70/85 deg. C max.

---

**Table of Contents**

<b>FEATURES</b> .....	<b>1</b>
<b>OVERVIEW</b> .....	<b>2</b>
Processor Core - ARM920T .....	6
MaverickKey™ Unique ID .....	6
General Purpose Memory Interface (SDRAM, SRAM, ROM, FLASH) .....	6
Ethernet Media Access Controller (MAC) .....	7
Serial Interfaces (SPI, I2S, and AC '97) .....	7
12-bit Analog-to-digital Converter (ADC) .....	7
Universal Asynchronous Receiver/Transmitters (UARTs) .....	8
Dual Port USB Host .....	8
Two-Wire Interface With EEPROM Support .....	8
Real-Time Clock with Software Trim .....	8
PLL and Clocking .....	9
Timers .....	9
Interrupt Controller .....	9
Dual LED Drivers .....	9
General Purpose Input/Output (GPIO) .....	9
Reset and Power Management .....	10
Hardware Debug Interface .....	10
12-Channel DMA Controller .....	10
Internal Boot ROM .....	10
<b>Electrical Specifications</b> .....	<b>11</b>
Absolute Maximum Ratings .....	11
Recommended Operating Conditions .....	11
DC Characteristics .....	12
<b>Timings</b> .....	<b>13</b>
Memory Interface .....	14
Ethernet MAC Interface .....	27
Audio Interface .....	29
AC'97 .....	32
ADC .....	33
JTAG .....	34
<b>208 Pin LQFP Package Outline</b> .....	<b>35</b>
208 Pin LQFP Pinout .....	36
<b>Acronyms and Abbreviations</b> .....	<b>40</b>
<b>Units of Measurement</b> .....	<b>40</b>
<b>ORDERING INFORMATION</b> .....	<b>41</b>

---

## List of Figures

Figure 1. Timing Diagram Drawing Key .....	13
Figure 2. SDRAM Load Mode Register Cycle Timing Measurement .....	14
Figure 3. SDRAM Burst Read Cycle Timing Measurement .....	15
Figure 4. SDRAM Burst Write Cycle Timing Measurement .....	16
Figure 5. SDRAM Auto Refresh Cycle Timing Measurement .....	17
Figure 6. Static Memory Multiple Word Read 8-bit Cycle Timing Measurement .....	18
Figure 7. Static Memory Multiple Word Write 8-bit Cycle Timing Measurement .....	19
Figure 8. Static Memory Multiple Word Read 16-bit Cycle Timing Measurement .....	20
Figure 9. Static Memory Multiple Word Write 16-bit Cycle Timing Measurement .....	21
Figure 10. Static Memory Burst Read Cycle Timing Measurement .....	22
Figure 11. Static Memory Burst Write Cycle Timing Measurement .....	23
Figure 12. Static Memory Single Read Wait Cycle Timing Measurement .....	24
Figure 13. Static Memory Single Write Wait Cycle Timing Measurement .....	25
Figure 14. Static Memory Turnaround Cycle Timing Measurement .....	26
Figure 15. Ethernet MAC Timing Measurement .....	28
Figure 16. <i>T</i> /Single Transfer Timing Measurement .....	29
Figure 17. Microwire Frame Format, Single Transfer .....	29
Figure 18. SPI Format with SPH=1 Timing Measurement .....	30
Figure 19. Inter-IC Sound (I2S) Timing Measurement .....	31
Figure 20. AC '97 Configuration Timing Measurement .....	32
Figure 21. ADC Transfer Function .....	33
Figure 22. JTAG Timing Measurement .....	34

---

**List of Tables**

Table A. Change History .....	2
Table B. General Purpose Memory Interface Pin Assignments .....	6
Table C. Ethernet Media Access Controller Pin Assignments .....	7
Table D. Audio Interfaces Pin Assignment .....	7
Table E. 12-bit Analog-to-Digital Converter Pin Assignments .....	7
Table F. Universal Asynchronous Receiver/Transmitters Pin Assignments .....	8
Table G. Dual Port USB Host Pin Assignments .....	8
Table H. Two-Wire Port with EEPROM Support Pin Assignments .....	8
Table I. Real-Time Clock with Pin Assignments .....	8
Table J. PLL and Clocking Pin Assignments .....	9
Table K. Interrupt Controller Pin Assignment .....	9
Table L. Dual LED Pin Assignments .....	9
Table M. General Purpose Input/Output Pin Assignment .....	9
Table N. Reset and Power Management Pin Assignments .....	10
Table O. Hardware Debug Interface .....	10
Table P. Pin List in Numerical Order by Pin Number .....	36
Table Q. Pin Description .....	38
Table R. Pin Multiplex Usage Information .....	39

## Processor Core - ARM920T

The ARM920T is a Harvard architecture processor with separate 16-kbyte instruction and data caches with an 8-word line length but a unified memory. The processor utilizes a five-stage pipeline consisting of fetch, decode, execute, memory, and write stages. Key features include:

- ARM (32-bit) and Thumb (16-bit compressed) instruction sets
- 32-bit Advanced Micro-Controller Bus Architecture (AMBA)
- 16 kbyte Instruction Cache with lockdown
- 16 kbyte Data Cache (programmable write-through or write-back) with lockdown
- MMU for Linux<sup>®</sup>, Microsoft<sup>®</sup> Windows<sup>®</sup> CE and other operating systems
- Translation Look Aside Buffers with 64 Data and 64 Instruction Entries
- Programmable Page Sizes of 1 Mbyte, 64 kbyte, 4 kbyte, and 1 kbyte
- Independent lockdown of TLB Entries

## MaverickKey<sup>™</sup> Unique ID

MaverickKey unique hardware programmed IDs are a solution to the growing concern over secure web content and commerce. With Internet security playing an important role in the delivery of digital media such as books or music, traditional software methods are quickly becoming unreliable. The MaverickKey unique IDs provide OEMs with a method of utilizing specific hardware IDs such as those assigned for SDMI (Secure Digital Music Initiative) or any other authentication mechanism.

Both a specific 32-bit ID as well as a 128-bit random ID is programmed into the EP9301 through the use of laser probing technology. These IDs can then be used to match secure copyrighted content with the ID of the target device the EP9301 is powering, and then deliver the copyrighted information over a secure connection. In addition, secure transactions can benefit by also matching device IDs to server IDs. MaverickKey IDs provide a level of hardware security required for today's Internet appliances.

## General Purpose Memory Interface (SDRAM, SRAM, ROM, FLASH)

The EP9301 features a unified memory address model where all memory devices are accessed over a common address/data bus. Memory accesses are performed via the Processor bus. The SRAM memory controller supports 8- and 16-bit devices and accommodates an internal boot ROM concurrently with 16-bit SDRAM memory.

- 1 to 4 banks of 16-bit, 66 MHz SDRAM
- Address and data bus shared between SDRAM, SRAM, ROM, and FLASH memory
- NOR FLASH memory supported

Table B. General Purpose Memory Interface Pin Assignments

Pin Mnemonic	Pin Description
SDCLK	SDRAM Clock
SDCLKEN	SDRAM Clock Enable
SDCSn[3:0]	SDRAM Chip Selects 3-0
RASn	SDRAM RAS
CASn	SDRAM CAS
SDWEn	SDRAM Write Enable
CSn[7:6] and CSn[3:0]	Chip Selects 7, 6, 3, 2, 1, 0
AD[25:0]	Address Bus 25-0
DA[15:0]	Data Bus 15-0
DQMn[1:0]	SDRAM Output Enables / Data Masks
WRn	SRAM Write Strobe
RDn	SRAM Read / OE Strobe
WAITn	SRAM Wait Input

## Ethernet Media Access Controller (MAC)

The MAC subsystem is compliant with the ISO/TEC 802.3 topology for a single shared medium with several stations. Multiple MII-compliant PHYs are supported. Features include:

- Supports 1/10/100 Mbps transfer rates for home / small-business / large-business applications
- Interfaces to an off-chip PHY through industry standard Media Independent Interface (MII)

**Table C. Ethernet Media Access Controller Pin Assignments**

Pin Mnemonic	Pin Description
MDC	Management Data Clock
MDIO	Management Data I/O
RXCLK	Receive Clock
MIIRXD[3:0]	Receive Data
RXDVAL	Receive Data Valid
RXERR	Receive Data Error
TXCLK	Transmit Clock
MIITXD[3:0]	Transmit Data
TXEN	Transmit Enable
TXERR	Transmit Error
CRS	Carrier Sense
CLD	Collision Detect

## Serial Interfaces (SPI, I<sup>2</sup>S, and AC '97)

The Serial Peripheral Interface (SPI) port can be configured as a master or a slave, supporting the National Semiconductor<sup>®</sup>, Motorola<sup>®</sup>, and Texas Instruments<sup>®</sup> signaling protocols.

The AC'97 port supports multiple codecs for multichannel audio output with a single stereo input. The I<sup>2</sup>S port supports stereo 24-bit audio.

These ports are multiplexed so that the I<sup>2</sup>S port will take over either the AC'97 pins or the SPI pins.

- Normal Mode: One SPI Port and one AC'97 Port
- I<sup>2</sup>S on SSP Mode: One AC'97 Port and one I<sup>2</sup>S Port
- I<sup>2</sup>S on AC'97 Mode: One SPI Port and one I<sup>2</sup>S Port

*Note: I<sup>2</sup>S may not be output on AC'97 and SSP ports at the same time.*

**Table D. Audio Interfaces Pin Assignment**

Pin Name	Normal Mode	I <sup>2</sup> S on SSP Mode	I <sup>2</sup> S on AC'97 Mode
	Pin Description	Pin Description	Pin Description
SCLK1	SPI Bit Clock	I2S Serial Clock	SPI Bit Clock
SFRM1	SPI Frame Clock	I2S Frame Clock	SPI Frame Clock
SSPRX1	SPI Serial Input	I2S Serial Input	SPI Serial Input
SSPTX1	SPI Serial Output	I2S Serial Output	SPI Serial Output
		(No I2S Master Clock)	
ARSTn	AC'97 Reset	AC'97 Reset	I2S Master Clock
ABITCLK	AC'97 Bit Clock	AC'97 Bit Clock	I2S Serial Clock
ASYN	AC'97 Frame Clock	AC'97 Frame Clock	I2S Frame Clock
ASDI	AC'97 Serial Input	AC'97 Serial Input	I2S Serial Input
ASDO	AC'97 Serial Output	AC'97 Serial Output	I2S Serial Output

## 12-bit Analog-to-digital Converter (ADC)

The ADC block consists of a 12-bit analog-to-digital converter with a analog input multiplexer. The multiplexer can select to measure battery voltage and other miscellaneous voltages on the external measurement pins. Features include:

- 5 external pins for ADC measurement
- Measurement pin input range: 0 to 3.3 V.
- ADC-conversion-complete interrupt signal

**Table E. 12-bit Analog-to-Digital Converter Pin Assignments**

Pin Mnemonic	Pin Description
ADC[0] (Ym, pin 135)	External Analog Measurement Input
ADC[1] (sXp, pin 134)	External Analog Measurement Input
ADC[2] (sXm, pin 133)	External Analog Measurement Input
ADC[3] (sYp, pin 132)	External Analog Measurement Input
ADC[4] (sYm, pin 131)	External Analog Measurement Input

## Universal Asynchronous Receiver/Transmitters (UARTs)

Two 16550-compatible UARTs are supplied. One provides asynchronous HDLC (High-level Data Link Control) protocol support for full duplex transmit and receive. The HDLC receiver handles framing, address matching, CRC checking, control-octet transparency, and optionally passes the CRC to the host at the end of the packet. The HDLC transmitter handles framing, CRC generation, and control-octet transparency. The host must assemble the frame in memory before transmission. The HDLC receiver and transmitter use the UART FIFOs to buffer the data streams. The second UART provides IrDA<sup>®</sup> compatibility.

- UART1 supports modem bit rates up to 115.2 kbps, supports HDLC and includes a 16 byte FIFO for receive and a 16 byte FIFO for transmit. Interrupts are generated on Rx, Tx and modem status change.
- UART2 contains an IrDA encoder operating at either the slow (up to 115 kbps), medium (0.576 or 1.152 Mbps), or fast (4 Mbps) IR data rates. It also has a 16 byte FIFO for receive and a 16 byte FIFO for transmit.

**Table F. Universal Asynchronous Receiver/Transmitters Pin Assignments**

Pin Mnemonic	Pin Name - Description
TXD0	UART1 Transmit
RXD0	UART1 Receive
CTSn	UART1 Clear To Send / Transmit Enable
DSRn / DCDn	UART1 Data Set Ready / Data Carrier Detect
DTRn	UART1 Data Terminal Ready
RTSn	UART1 Ready To Send
EGPIO[0] / RI	UART1 Ring Indicator
TXD1 / SIROUT	UART2 Transmit / IrDA Output
RXD1 / SIRIN	UART2 Receive / IrDA Input

## Dual Port USB Host

The USB Open Host Controller Interface (Open HCI) provides full speed serial communications ports at a baud rate of 12 Mbits/sec. Up to 127 USB devices (printer, mouse, camera, keyboard, etc.) and USB hubs can be connected to the USB host in the USB “tiered-start” topology.

This includes the following feature:

- Compliance with the USB 2.0 specification
- Compliance with the Open HCI Rev 1.0 specification

- Supports both low speed (1.5 Mbps) and full speed (12 Mbps) USB device connections
- Root HUB integrated with 2 downstream USB ports
- Transceiver buffers integrated, over-current protection on ports
- Supports power management
- Operates as a master on the bus

The Open HCI host controller initializes the master DMA transfer with the AHB bus:

- Fetches endpoint descriptors and transfer descriptors
- Accesses endpoint data from system memory
- Accesses the HC communication area
- Writes status and retire transfer descriptor

**Table G. Dual Port USB Host Pin Assignments**

Pin Mnemonic	Pin Name - Description
USBp[2,0]	USB Positive signals
USBm[2,0]	USB Negative Signals

*Note: USBm[1] and USBp[1] are not bonded out.*

## Two-Wire Interface With EEPROM Support

The two-wire interface provides communication and control for synchronous-serial-driven devices.

**Table H. Two-Wire Port with EEPROM Support Pin Assignments**

Pin Mnemonic	Pin Name - Description	Alternative Usage
EECLK	Two-wire Interface Clock	General Purpose I/O
EEDATA	Two-wire Interface Data	General Purpose I/O

## Real-Time Clock with Software Trim

The software trim feature on the real time clock (RTC) provides software controlled digital compensation of the 32.768 KHz input clock. This compensation is accurate to  $\pm 1.24$  sec/month.

*Note: A real time clock must be connected to RTCXTALI or the EP9301 device will not boot.*

**Table I. Real-Time Clock with Pin Assignments**

Pin Mnemonic	Pin Name - Description
RTCXTALI	Real-Time Clock Oscillator Input
RTCXTALO	Real-Time Clock Oscillator Output



## PLL and Clocking

The Processor and the Peripheral Clocks operate from a single 14.7456 MHz crystal.

The Real Time Clock operates from a 32.768 KHz external oscillator.

**Table J. PLL and Clocking Pin Assignments**

Pin Mnemonic	Pin Name - Description
XTALI	Main Oscillator Input
XTALO	Main Oscillator Output
VDD_PLL	Main Oscillator Power
GND_PLL	Main Oscillator Ground

## Timers

The Watchdog Timer ensures proper operation by requiring periodic attention to prevent a reset-on-time-out.

Two 16-bit timers operate as free-running down counters or as periodic timers for fixed-interval interrupts and have a range of 0.03 ms to 4.27 seconds.

One 32-bit timer, plus a 6-bit prescale counter, has a range of 0.03  $\mu$ s to 73.3 hours.

One 40-bit debug timer, plus a 6-bit prescale counter, has a range of 1.0  $\mu$ s to 12.7 days.

## Interrupt Controller

The interrupt controller allows up to 54 interrupts to generate an Interrupt Request (IRQ) or Fast Interrupt Request (FIQ) signal to the processor core. Thirty-two hardware priority assignments are provided for assisting IRQ vectoring, and two levels are provided for FIQ vectoring. This allows time-critical interrupts to be processed in the shortest time possible. Internal interrupts may be programmed as active high or active low level sensitive inputs. GPIO pins programmed as interrupts may be programmed as active high level sensitive, active low level sensitive, rising edge triggered, falling edge triggered, or combined rising/falling edge triggered.

- Supports 54 interrupts from a variety of sources (such as UARTs, GPIO and ADC)
- Routes interrupt sources to either the ARM920T's IRQ or FIQ (Fast IRQ) inputs
- Three dedicated off-chip interrupt lines INT[2:0] operate as active-high level-sensitive interrupts
- Any of the 19 GPIO lines maybe configured to generate interrupts

- Software supported priority mask for all FIQs and IRQs

**Table K. External Interrupt Controller Pin Assignment**

Pin Mnemonic	Pin Name - Description
INT[3] and INT[1:0]	External Interrupts 2, 1, 0

*Note: INT[2] is not bonded out.*

## Dual LED Drivers

Two pins are assigned specifically to drive external LEDs.

**Table L. Dual LED Pin Assignments**

Pin Mnemonic	Pin Name - Description	Alternative Usage
GRLED	Green LED	General Purpose I/O
REDLED	Red LED	General Purpose I/O

## General Purpose Input/Output (GPIO)

The 16 EGPIO and the 3 FGPIO pins may each be configured individually as an output, an input or an interrupt input.

There are 10 pins that may alternatively be used as input, output, or open-drain pins, but do not support interrupts. These pins are:

- Ethernet MDIO
- Both LED Outputs
- EEPROM Clock and Data
- HGPIO[5:2]
- CGPIO[0]

6 pins may alternatively be used as inputs only:

- CTS<sub>n</sub>, DSR<sub>n</sub> / DCD<sub>n</sub>
- 3 Interrupt Lines

2 pins may alternatively be used as outputs only:

- RTS<sub>n</sub>
- ARST<sub>n</sub>

**Table M. General Purpose Input/Output Pin Assignment**

Pin Mnemonic	Pin Name - Description
EGPIO[15:0]	Expanded General Purpose Input / Output Pins with Interrupts
FGPIO[3:1]	Expanded General Purpose Input / Output Pins with Interrupts

## Reset and Power Management

The chip may be reset through the PRSTn pin or through the open drain common reset pin, RSTOn.

Clocks are managed on a peripheral-by-peripheral basis and may be turned off to conserve power.

The processor clock is dynamically adjustable from 0 to 166 MHz.

**Table N. Reset and Power Management Pin Assignments**

Pin Mnemonic	Pin Name - Description
PRSTn	Power On Reset
RSTOn	User Reset In/Out – Open Drain – Preserves Real Time Clock value

## Hardware Debug Interface

The JTAG interface allows use of ARM's Multi-ICE or other in-circuit emulators.

**Table O. Hardware Debug Interface**

Pin Mnemonic	Pin Name - Description
TCK	JTAG Clock
TDI	JTAG Data In
TDO	JTAG Data Out
TMS	JTAG Test Mode Select
TRSTn	JTAG Port Reset

## 12-channel DMA Controller

The DMA module contains 12 separate DMA channels. Ten of these may be used for peripheral-to-memory or memory-to-peripheral access. Two of these are dedicated to memory-to-memory transfers. Each DMA channel is connected to the 16-bit DMA request bus.

The request bus is a collection of requests, Serial Audio and UARTs. Each DMA channel can be used independently or dedicated to any request signal. For each DMA channel, source and destination addressing can be independently programmed to increment, decrement, or stay at the same value. All DMA addresses are physical, not virtual addresses.

## Internal Boot ROM

The Internal 16 kbyte ROM allows booting from FLASH memory, SPI or UART. Consult the EP93xx User's Manual for operational details.

## Electrical Specifications

### Absolute Maximum Ratings

(All grounds = 0 V, all voltages with respect to 0 V)

Parameter	Symbol	Min	Max	Unit
Power Supplies	RVDD	-	3.96	V
	CVDD	-	2.16	V
	VDD_PLL	-	2.16	V
	VDD_ADC	-	3.96	V
Total Power Dissipation (Note 1)		-	2	W
Input Current per Pin, DC (Except supply pins)		-	±10	mA
Output current per pin, DC		-	±50	mA
Digital Input voltage (Note 2)		-0.3	RVDD+0.3	V
Storage temperature		-40	+125	°C

Note: 1. Includes all power generated by AC and/or DC output loading.  
 2. The power supply pins are at recommended maximum values.

**WARNING:** Operation beyond these limits may result in permanent damage to the device.  
 Normal operation is not guaranteed at these extremes.

### Recommended Operating Conditions

(All grounds = 0 V, all voltages with respect to 0 V)

Parameter	Symbol	Min	Typ	Max	Unit
Power Supplies	RVDD	3.0	3.3	3.6	V
	CVDD	1.71	1.80	1.94	V
	VDD_PLL	1.71	1.80	1.94	V
	VDD_ADC	3.0	3.3	3.6	V
Operating Ambient Temperature - Commercial	T <sub>A</sub>	0	+25	+70	°C
Operating Ambient Temperature - Industrial	T <sub>A</sub>	-40	+25	+85	°C
Processor Clock Speed - Commercial	FCLK	-	-	166	MHz
Processor Clock Speed - Industrial	FCLK	-	-	166	MHz
System Clock Speed - Commercial	HCLK	-	-	66	MHz
System Clock Speed - Industrial	HCLK	-	-	66	MHz

## DC Characteristics

( $T_A = 0$  to  $70^\circ\text{C}$ ;  $CVDD = VDD\_PLL = 1.8$ ;  $RVDD = 3.3\text{ V}$ ;  
All grounds =  $0\text{ V}$ ; all voltages with respect to  $0\text{ V}$  unless otherwise noted)

Parameter			Symbol	Min	Max	Unit
High level output voltage	$I_{out} = -4\text{ mA}$	(Note 3)	$V_{oh}$	$0.85 \times RVDD$	-	V
Low level output voltage	$I_{out} = 4\text{ mA}$		$V_{ol}$	-	$0.15 \times RVDD$	V
High level input voltage		(Note 4)	$V_{ih}$	$0.65 \times RVDD$	$VDD + 0.3$	V
Low level input voltage		(Note 4)	$V_{il}$	$-0.3$	$0.35 \times RVDD$	V
High level leakage current	$V_{in} = 3.3\text{ V}$	(Note 4)	$I_{ih}$	-	10	$\mu\text{A}$
Low level leakage current	$V_{in} = 0$	(Note 4)	$I_{il}$	-	-10	$\mu\text{A}$

Parameter		Min	Typ	Max	Unit
Power Supply Pins (Outputs Unloaded), $25^\circ\text{C}$					
Power Supply Current:	CVDD / VDD_PLL Total	-	180	230	$\text{mA}$
	RVDD	-	45	80	$\text{mA}$
Low-Power Mode Supply Current	CVDD / VDD_PLL Total	-	2	3.5	$\text{mA}$
	RVDD	-	1.0	2	$\text{mA}$

Note: 3. For open drain pins, high level output voltage is dependent on the external load.

4. All inputs that do not include internal pull-ups or pull-downs, must be externally driven for proper operation (See [Table Q on page 38](#)). If an input is not driven, it should be tied to power or ground, depending on the particular function. If an I/O pin is not driven and programmed as an input, it should be tied to power or ground through its own resistor.

## Timings

### Timing Diagram Conventions

This data sheet contains one or more timing diagrams. The following key explains the components used in these diagrams. Any variations are clearly labelled when they occur. Therefore, no additional meaning should be attached unless specifically stated.

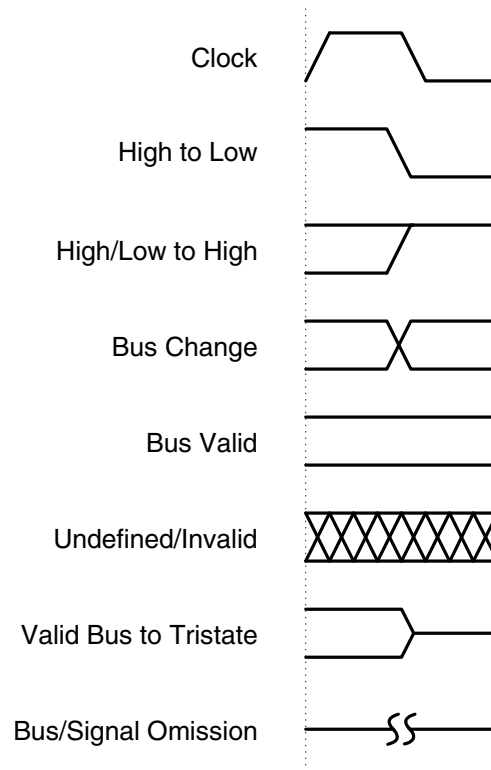

Figure 1. Timing Diagram Drawing Key

### Timing Conditions

Unless specified otherwise, the following conditions are true for all timing measurements.

- $T_A = 0$  to  $70^\circ\text{C}$
- $CVDD = VDD\_PLL = 1.8\text{V}$
- $RVDD = 3.3\text{V}$
- All grounds =  $0\text{V}$
- Logic 0 =  $0\text{V}$ , Logic 1 =  $3.3\text{V}$
- Output loading =  $50\text{pF}$
- Timing reference levels =  $1.5\text{V}$
- The Processor Bus Clock (HCLK) is programmable and is set by the user. The frequency is typically between  $33\text{MHz}$  and  $100\text{MHz}$  ( $92\text{MHz}$  for industrial conditions).

## Memory Interface

Figure 2 through Figure 5 define the timings associated with all phases of the SDRAM. The following table contains the values for the timings of each of the SDRAM modes.

Parameter	Symbol	Min	Typ	Max	Unit
SDCLK high time	$t_{clk\_high}$	-	$(t_{HCLK}) / 2$	-	ns
SDCLK low time	$t_{clk\_low}$	-	$(t_{HCLK}) / 2$	-	ns
SDCLK rise/fall time	$t_{clkrf}$	-	2	4	ns
Signal delay from SDCLK rising edge time	$t_d$	-	-	8	ns
Signal hold from SDCLK rising edge time	$t_h$	1	-	-	ns
DQMn delay from SDCLK rising edge time	$t_{DQd}$	-	-	8	ns
DQMn hold from SDCLK rising edge time	$t_{DQh}$	1	-	-	ns
DA valid setup to SDCLK rising edge time	$t_{DA_s}$	2	-	-	ns
DA valid hold from SDCLK rising edge time	$t_{DA_h}$	3	-	-	ns

### SDRAM Load Mode Register Cycle

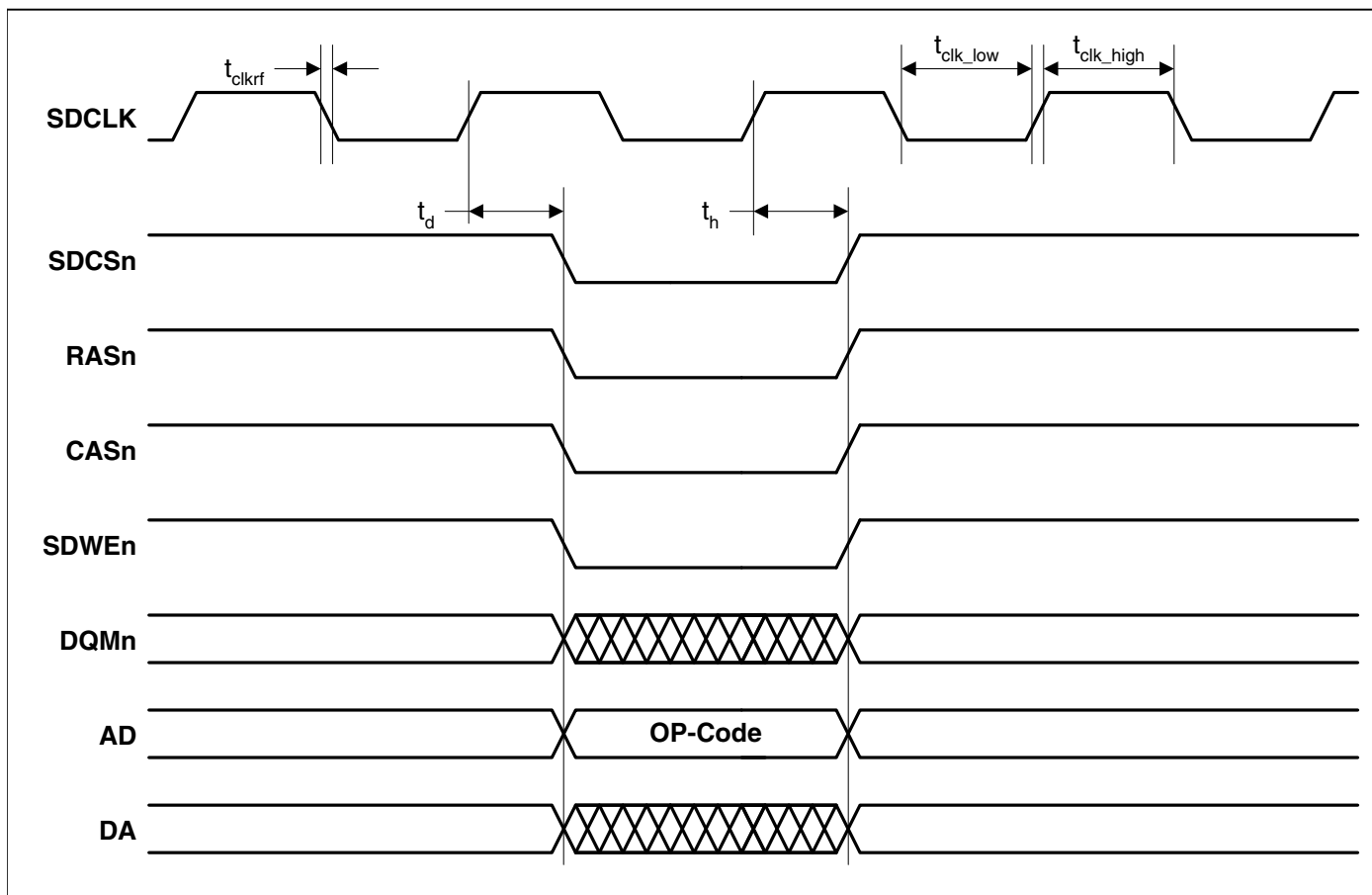
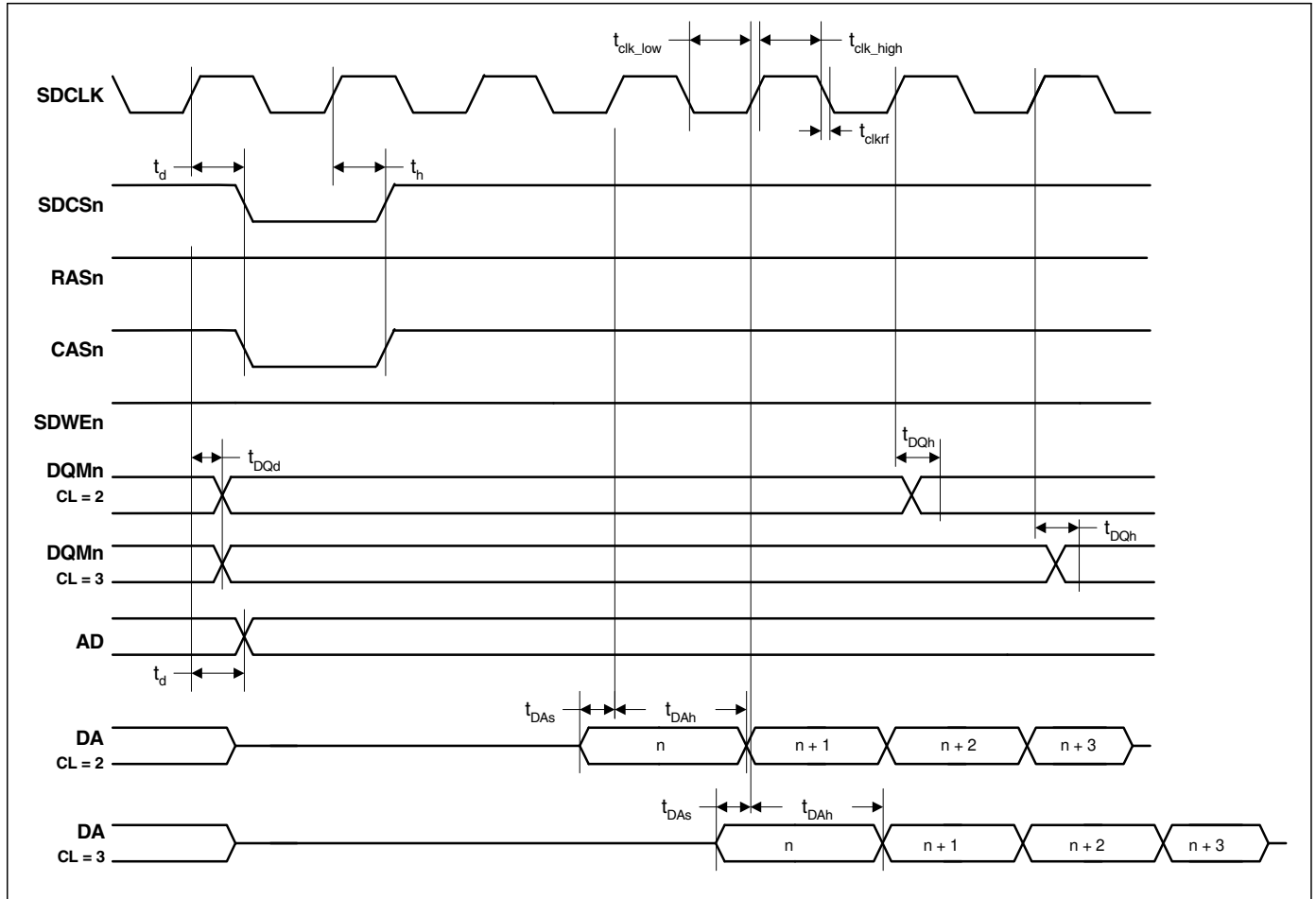

Figure 2. SDRAM Load Mode Register Cycle Timing Measurement

**SDRAM Burst Read Cycle**

**Figure 3. SDRAM Burst Read Cycle Timing Measurement**

### SDRAM Burst Write Cycle

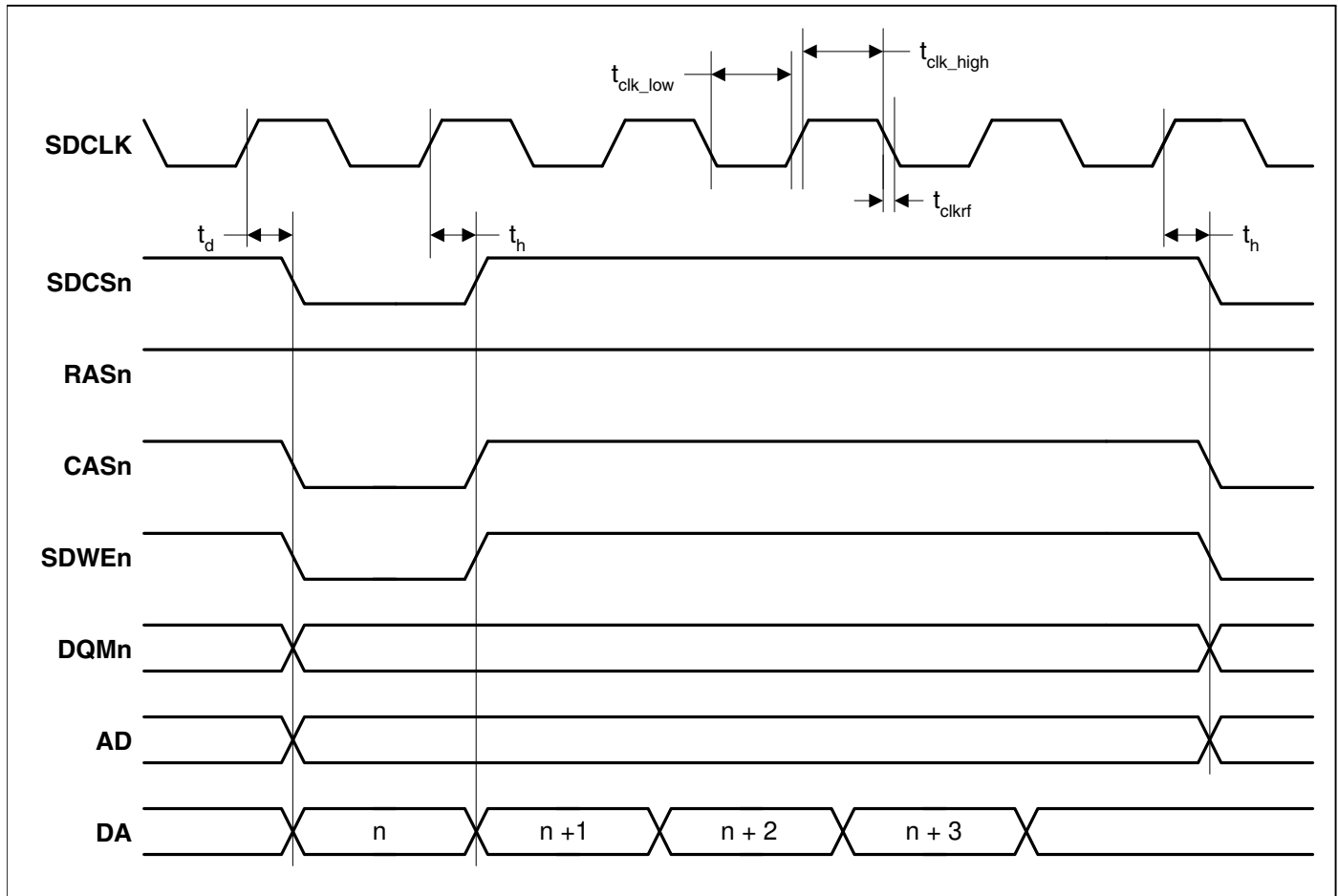
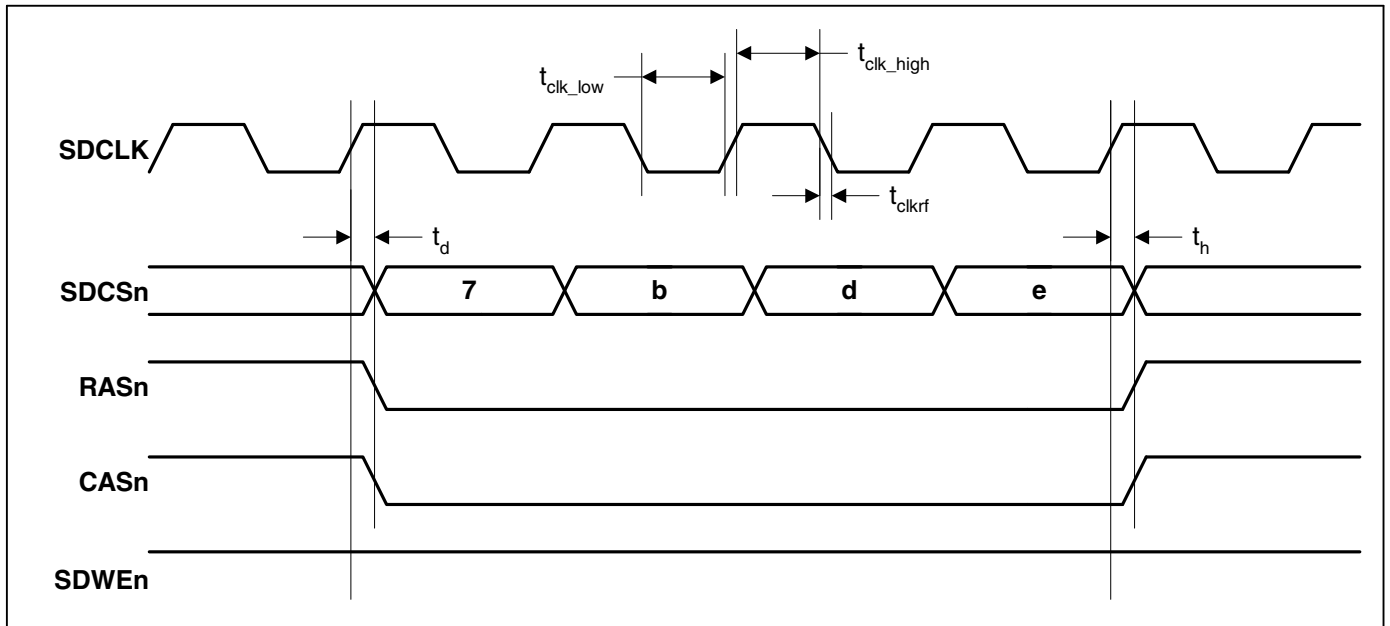

Figure 4. SDRAM Burst Write Cycle Timing Measurement



**SDRAM Auto Refresh Cycle**

Note: Chip select shown as bus to illustrate multiple devices being put into auto refresh in one access

**Figure 5. SDRAM Auto Refresh Cycle Timing Measurement**

**Static Memory 32-bit Read on 8-bit External Bus**

Parameter	Symbol	Min	Typ	Max	Unit
AD setup to CSn assert time	$t_{ADs}$	$t_{HCLK}$	-	-	ns
CSn assert to Address transition time	$t_{AD1}$	-	$t_{HCLK} \times (WST1 + 1)$	-	ns
Address assert time	$t_{AD2}$	-	$t_{HCLK} \times (WST1 + 1)$	-	ns
AD transition to CSn deassert time	$t_{AD3}$	-	$t_{HCLK} \times (WST1 + 2)$	-	ns
AD hold from CSn deassert time	$t_{ADh}$	$t_{HCLK}$	-	-	ns
RDn assert time	$t_{RDpwL}$	-	$t_{HCLK} \times (4 \times WST1 + 5)$	-	ns
CSn to RDn delay time	$t_{RDd}$	-	-	3	ns
CSn assert to DQMn assert delay time	$t_{DQMd}$	-	-	1	ns
DA setup to AD transition time	$t_{DAs1}$	15	-	-	ns
DA setup to RDn deassert time	$t_{DAs2}$	$t_{HCLK} + 12$	-	-	ns
DA hold from AD transition time	$t_{DAh1}$	0	-	-	ns
DA hold from RDn deassert time	$t_{DAh2}$	0	-	-	ns

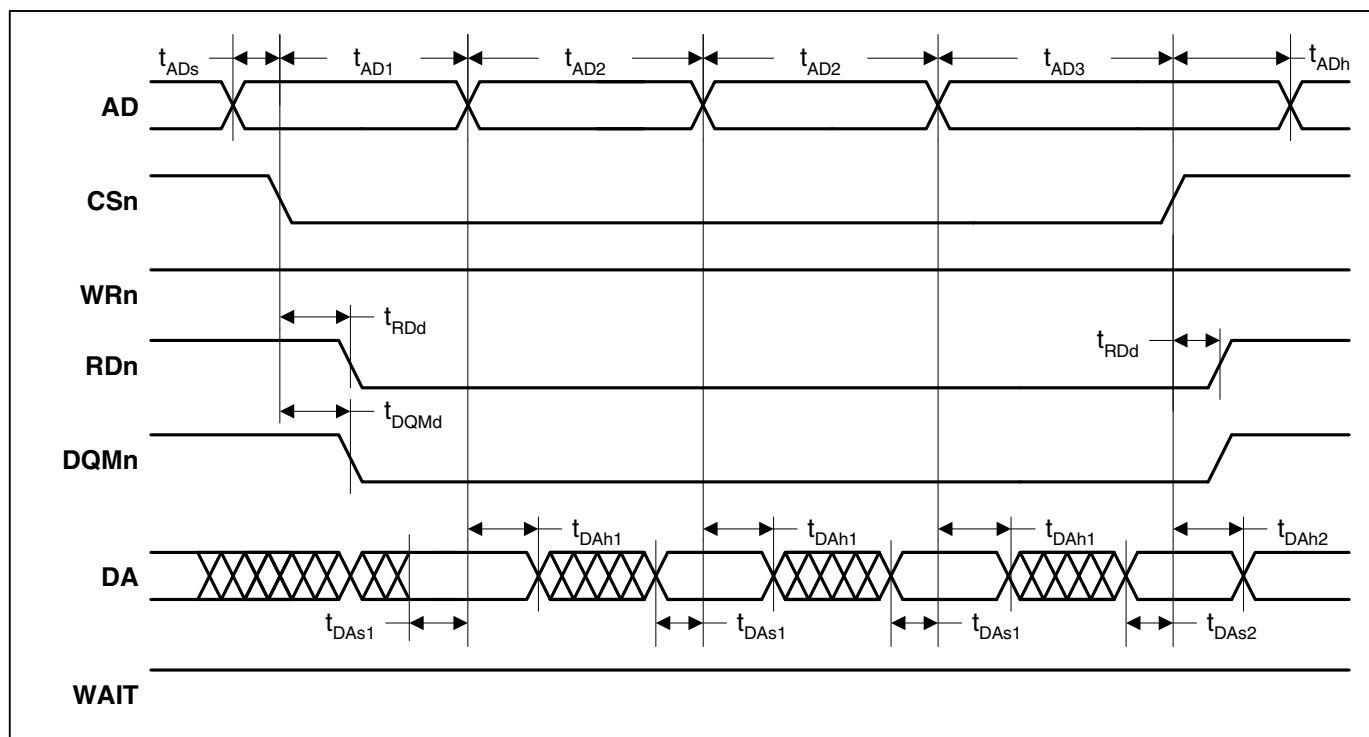
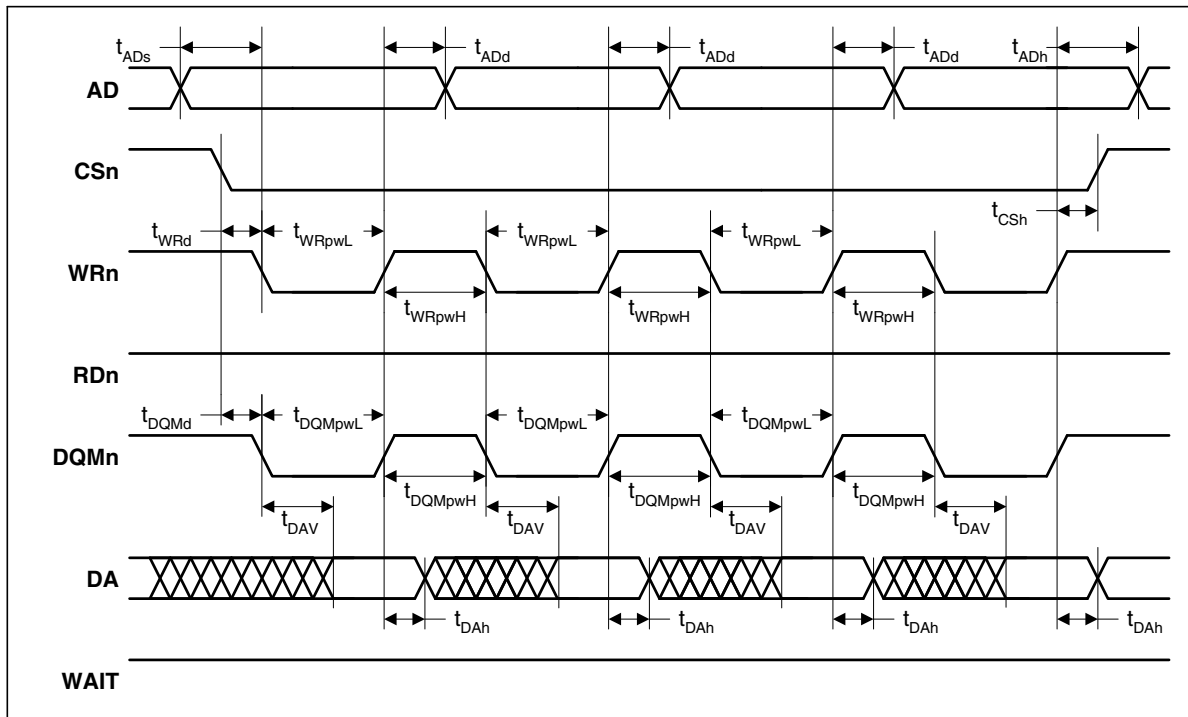

Figure 6. Static Memory Multiple Word Read 8-bit Cycle Timing Measurement

**Static Memory 32-bit Write on 8-bit External Bus**

Parameter	Symbol	Min	Typ	Max	Unit
AD setup to WRn assert time	$t_{ADs}$	$t_{HCLK} - 3$	-	-	ns
WRn/DQMn deassert to AD transition time	$t_{ADd}$	-	-	$t_{HCLK} + 6$	ns
AD hold from WRn deassert time	$t_{ADh}$	$t_{HCLK} \times 2$	-	-	ns
CSn hold from WRn deassert time	$t_{CSH}$	7	-	-	ns
CSn to WRn assert delay time	$t_{WRd}$	-	-	2	ns
WRn assert time	$t_{WRpwL}$	-	$t_{HCLK} \times (WST1 + 1)$	-	ns
WRn deassert time	$t_{WRpwH}$	-	$t_{HCLK} \times 2$	$(t_{HCLK} \times 2) + 14$	ns
CSn to DQMn assert delay time	$t_{DQMd}$	-	-	1	ns
DQMn assert time	$t_{DQMpwL}$	-	$t_{HCLK} \times (WST1 + 1)$	-	ns
DQMn deassert time	$t_{DQMpwH}$	-	-	$(t_{HCLK} \times 2) + 7$	ns
WRn / DQMn deassert to DA transition time	$t_{DAh}$	$t_{HCLK}$	-	-	ns
WRn / DQMn assert to DA valid time	$t_{DAV}$	-	-	8	ns

**Figure 7. Static Memory Multiple Word Write 8-bit Cycle Timing Measurement**

### Static Memory 32-bit Read on 16-bit External Bus

Parameter	Symbol	Min	Typ	Max	Unit
AD setup to CSn assert time	$t_{ADs}$	$t_{HCLK}$	-	-	ns
CSn assert to AD transition time	$t_{ADd1}$	-	$t_{HCLK} \times (WST1 + 1)$	-	ns
AD transition to CSn deassert time	$t_{ADd2}$	-	$t_{HCLK} \times (WST1 + 2)$	-	ns
AD hold from CSn deassert time	$t_{ADh}$	$t_{HCLK}$	-	-	ns
RDn assert time	$t_{RDpwL}$	-	$t_{HCLK} \times ((2 \times WST1) + 3)$	-	ns
CSn to RDn delay time	$t_{RDd}$	-	-	3	ns
CSn assert to DQMn assert delay time	$t_{DQMd}$	-	-	1	ns
DA setup to AD transition time	$t_{DAs1}$	15	-	-	ns
DA to RDn deassert time	$t_{DAs2}$	$t_{HCLK} + 12$	-	-	ns
DA hold from AD transition time	$t_{DAh1}$	0	-	-	ns
DA hold from RDn deassert time	$t_{DAh2}$	0	-	-	ns

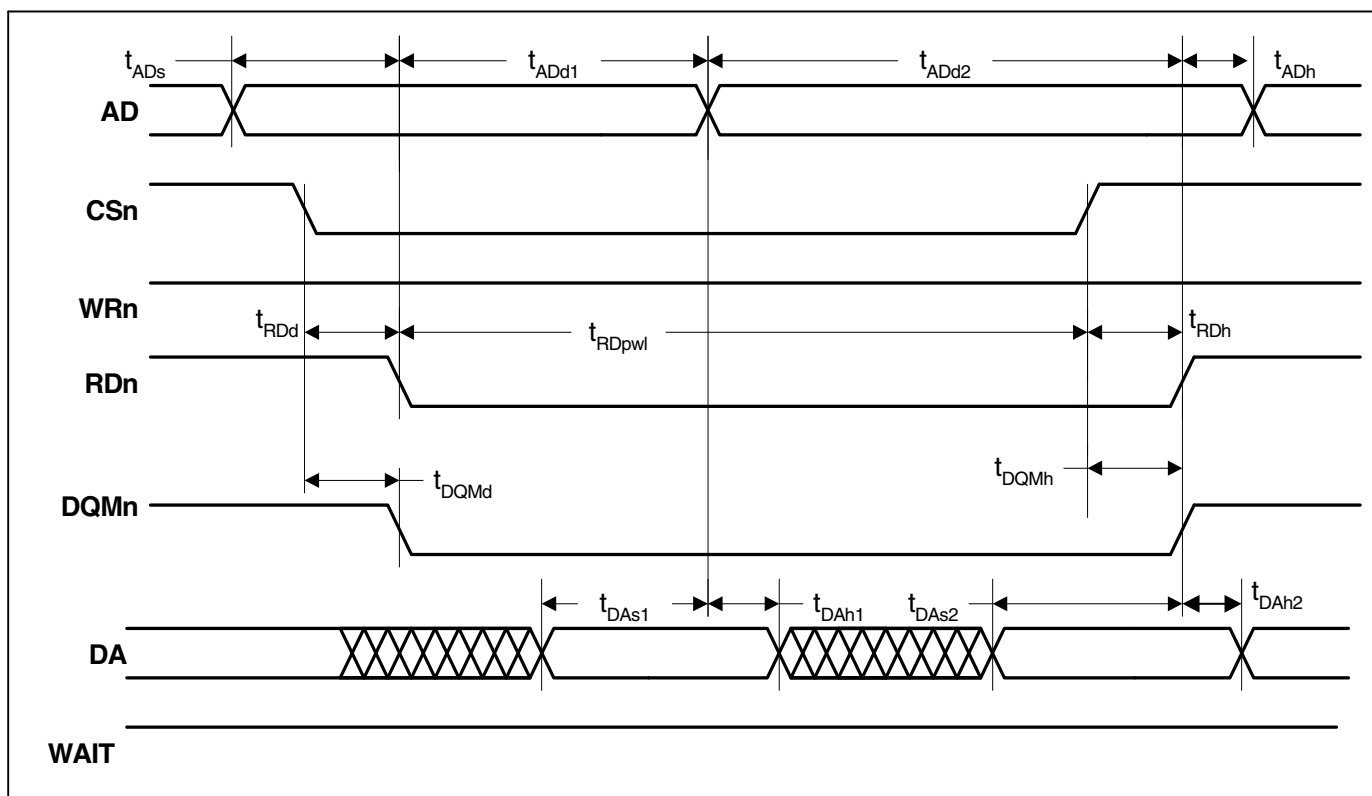
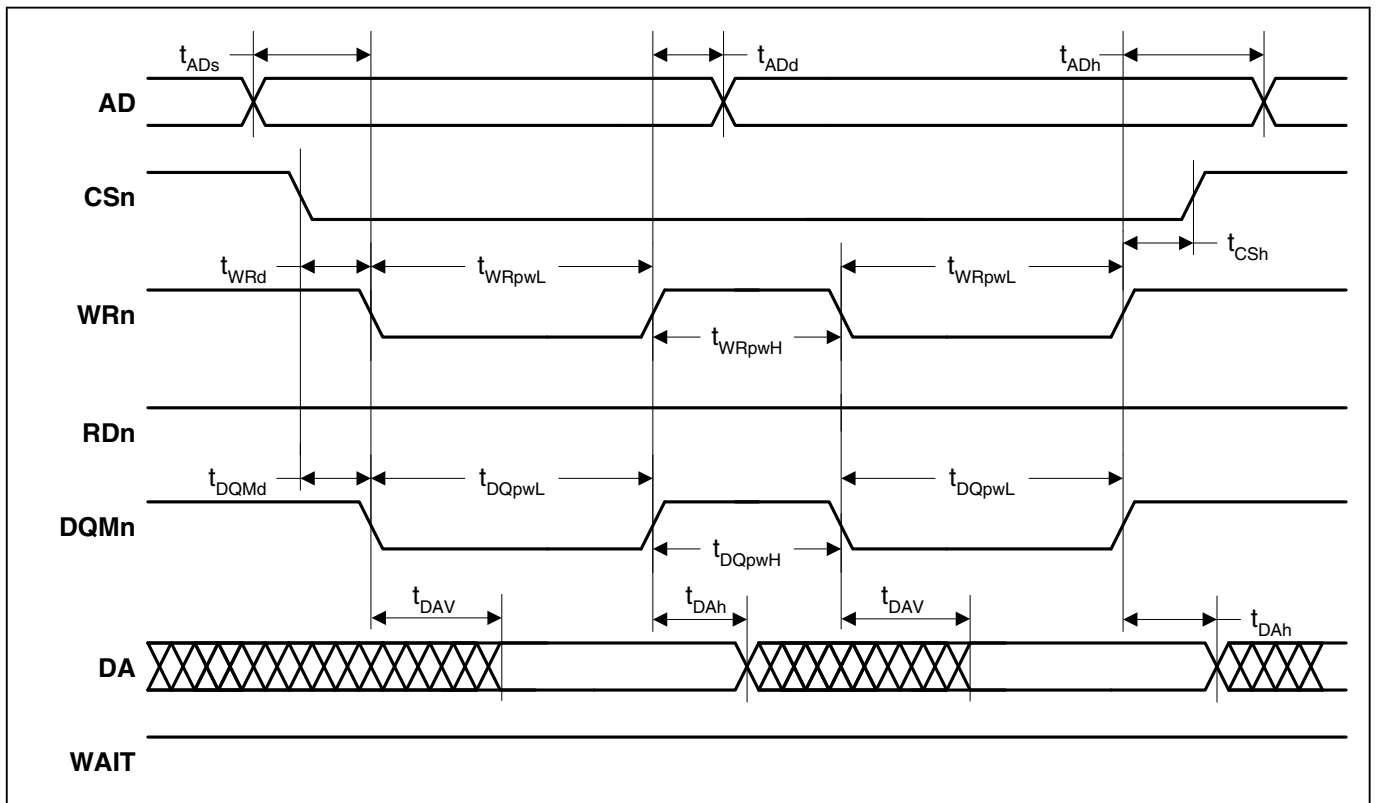

Figure 8. Static Memory Multiple Word Read 16-bit Cycle Timing Measurement

**Static Memory 32-bit Write on 16-bit External Bus**

Parameter	Symbol	Min	Typ	Max	Unit
AD setup to WRn assert time	$t_{ADs}$	$t_{HCLK} - 3$	-	-	ns
WRn/DQMn deassert to AD transition time	$t_{ADd}$	-	-	$t_{HCLK} + 6$	ns
AD hold from WRn deassert time	$t_{ADh}$	$t_{HCLK} \times 2$	-	-	ns
CSn hold from WRn deassert time	$t_{CSH}$	7	-	-	ns
CSn to WRn assert delay time	$t_{WRd}$	-	-	2	ns
WRn assert time	$t_{WRpWL}$	-	$t_{HCLK} \times (WST1 + 1)$	-	ns
WRn deassert time	$t_{WRpWH}$	-	-	$(t_{HCLK} \times 2) + 14$	ns
CSn to DQMn assert delay time	$t_{DQMd}$	-	-	1	ns
DQMn assert time	$t_{DQMpWL}$	-	$t_{HCLK} \times (WST1 + 1)$	-	ns
DQMn deassert time	$t_{DQMpWH}$	-	-	$(t_{HCLK} \times 2) + 7$	ns
WRn / DQMn deassert to DA transition time	$t_{DAh1}$	$t_{HCLK}$	-	-	ns
WRn / DQMn assert to DA valid time	$t_{DAV}$	-	-	8	ns

**Figure 9. Static Memory Multiple Word Write 16-bit Cycle Timing Measurement**

### Static Memory Burst Read Cycle

Parameter	Symbol	Min	Typ	Max	Unit
CSn assert to Address 1 transition time	$t_{ADd1}$	-	$t_{HCLK} \times (WST1 + 1)$	-	ns
Address assert time	$t_{ADd2}$	-	$t_{HCLK} \times (WST2 + 1)$	-	ns
AD transition to CSn deassert time	$t_{ADd3}$	-	$t_{HCLK} \times (WST1 + 2)$	-	ns
AD hold from CSn deassert time	$t_{ADh}$	$t_{HCLK}$	-	-	ns
CSn to RDn delay time	$t_{RDd}$	-	-	3	ns
CSn to DQMn assert delay time	$t_{DQMd}$	-	-	1	ns
DA setup to AD transition time	$t_{DAs1}$	15	-	-	ns
DA setup to CSn deassert time	$t_{DAs2}$	$t_{HCLK} + 12$	-	-	ns
DA hold from AD transition time	$t_{DAh1}$	0	-	-	ns
DA hold from RDn deassert time	$t_{DAh2}$	0	-	-	ns

Note: These characteristics are valid when the Page Mode Enable (Burst Mode) bit is set. See the User's Guide for details.

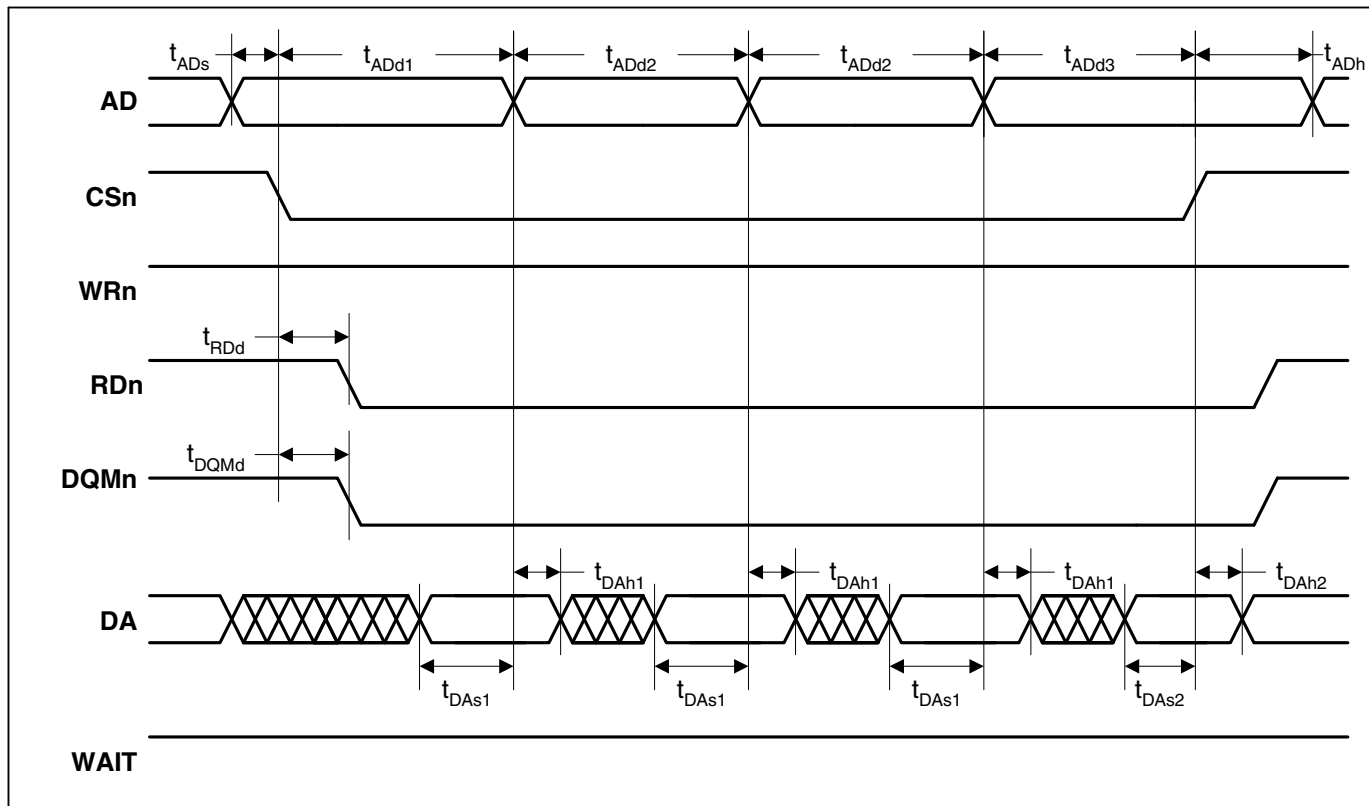

Figure 10. Static Memory Burst Read Cycle Timing Measurement

### Static Memory Burst Write Cycle

Parameter	Symbol	Min	Typ	Max	Unit
AD setup to WRn assert time	$t_{ADs}$	$t_{HCLK} - 3$			ns
AD hold from WRn deassert time	$t_{ADh}$	$t_{HCLK} \times 2$			ns
WRN/DQMn deassert to AD transition time	$t_{ADd}$			$t_{HCLK} + 6$	ns
CSn hold from WRn deassert time	$t_{CSH}$	7			ns
CSn to WRn assert delay time	$t_{WRd}$			2	ns
CSn to DQMn assert delay time	$t_{DQMd}$			1	ns
DQMn assert time	$t_{DQpwL}$		$t_{HCLK} \times (WST1 + 1)$		ns
DQMn deassert time	$t_{DQpwH}$			$(t_{HCLK} \times 2) + 14$	ns
WRn assert time	$t_{WRpwL}$		$t_{HCLK} \times (WST1 + 11)$		ns
WRn deassert time	$t_{WRpwH}$			$(t_{HCLK} \times 2) + 7$	ns
WRn/DQMn deassert to DA transition time	$t_{DAh}$	$t_{HCLK}$			ns
WRn/DQMn assert to DA valid time	$t_{DAv}$			8	ns

Note: These characteristics are valid when the Page Mode Enable (Burst Mode) bit is set. See the User's Guide for details.

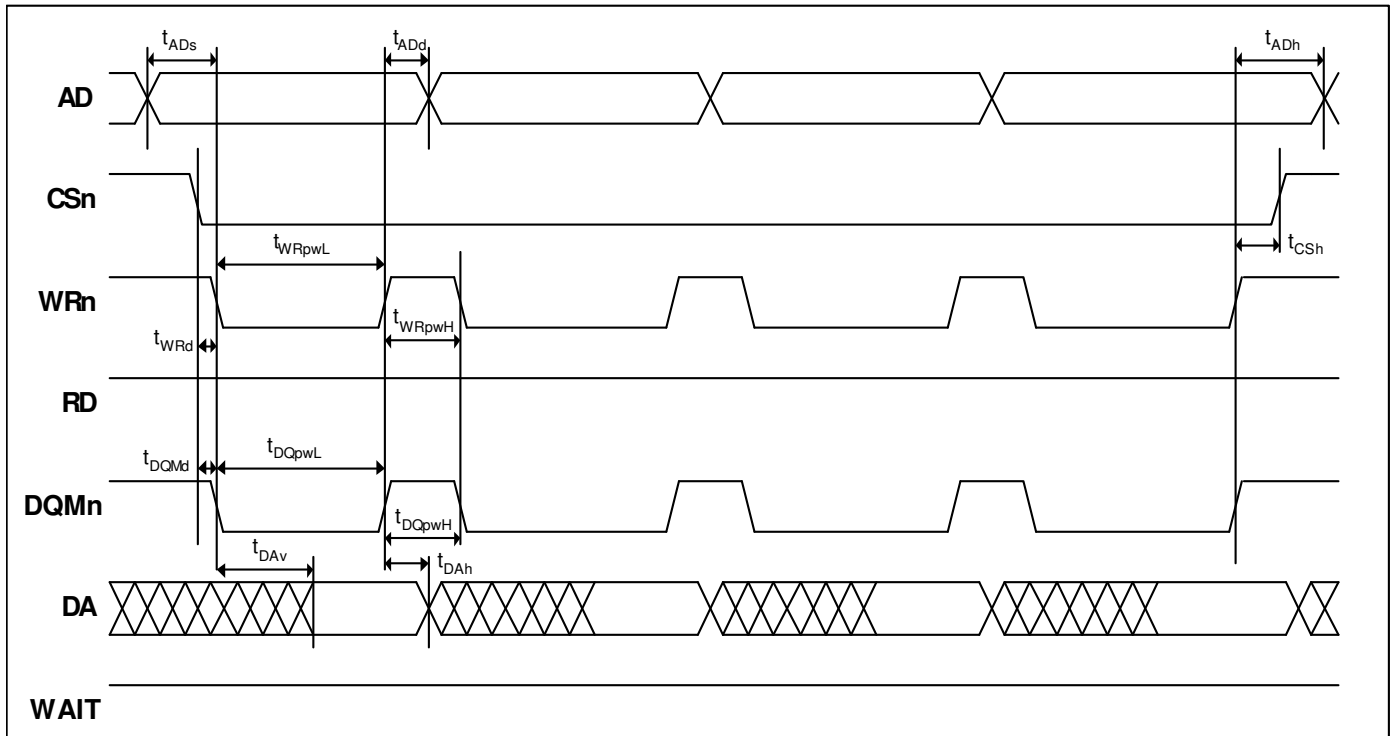

Figure 11. Static Memory Burst Write Cycle Timing Measurement

**Static Memory Single Read Wait Cycle**

Parameter	Symbol	Min	Typ	Max	Unit
CSn assert to WAIT time	$t_{WAITd}$	-	-	$t_{HCLK} \times (WST1-2)$	ns
WAIT assert time	$t_{WAITpw}$	$t_{HCLK} \times 2$	-	$t_{HCLK} \times 510$	ns
WAIT to CSn deassert delay time	$t_{CSnd}$	$t_{HCLK} \times 3$	-	$t_{HCLK} \times 5$	ns

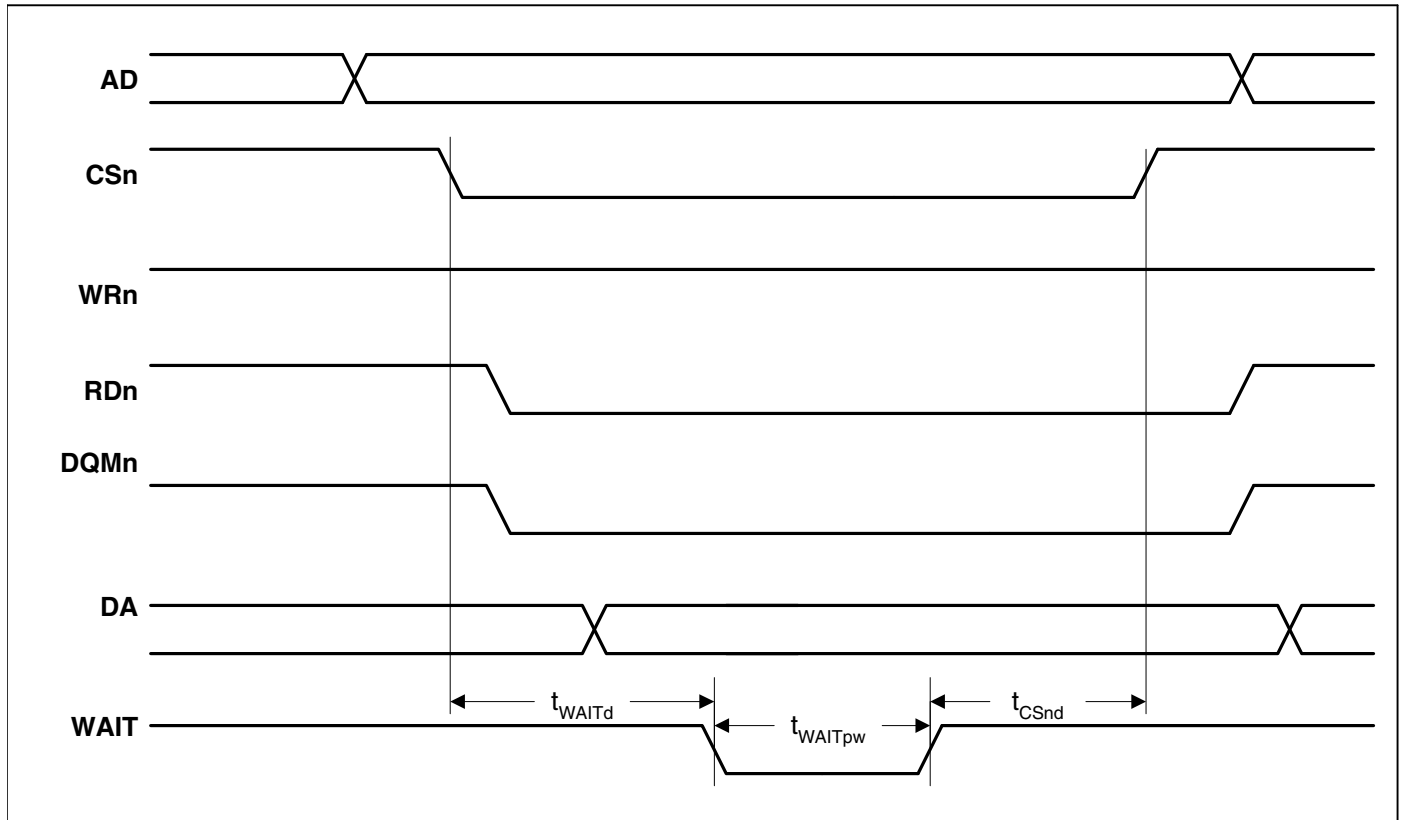
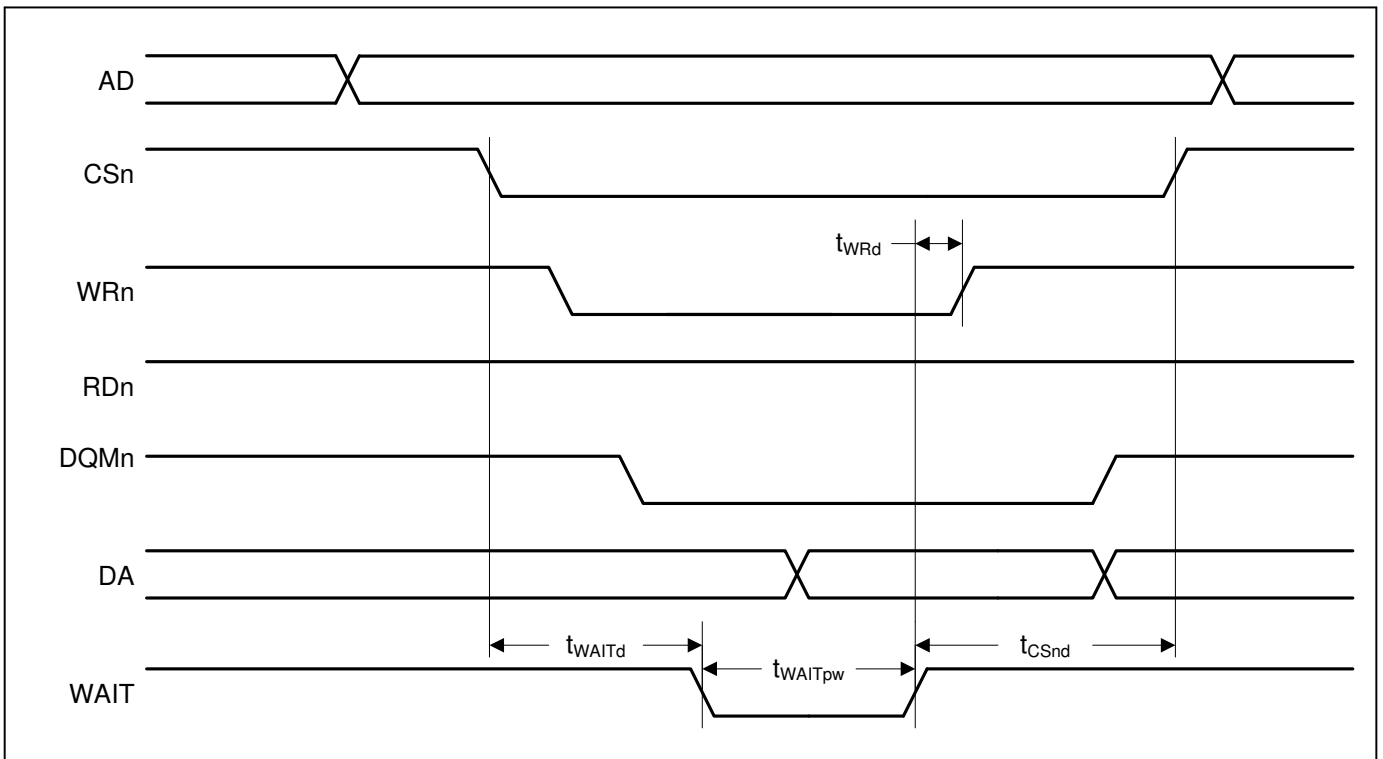

Figure 12. Static Memory Single Read Wait Cycle Timing Measurement



**Static Memory Single Write Wait Cycle**

Parameter	Symbol	Min	Typ	Max	Unit
WAIT to WRn deassert delay time	$t_{WRd}$	$t_{HCLK} \times 2$	-	$t_{HCLK} \times 4$	ns
CSn assert to WAIT time	$t_{WAITd}$	-	-	$t_{HCLK} \times (WST1-2)$	ns
WAIT assert time	$t_{WAITpw}$	$t_{HCLK} \times 2$	-	$t_{HCLK} \times 510$	ns
WAIT to CSn deassert delay time	$t_{CSnd}$	$t_{HCLK} \times 3$	-	$t_{HCLK} \times 5$	ns

**Figure 13. Static Memory Single Write Wait Cycle Timing Measurement**

### Static Memory Turnaround Cycle

Parameter	Symbol	Min	Typ	Max	Unit
CSnX deassert to CSnY assert time	$t_{BTcyc}$	-	$t_{HCLK} \times (IDCY+1)$	-	ns

- Notes: 1. X and Y represent any two chip select numbers.  
 2. IDCY occurs on read-to-write and write-to-read.  
 3. IDCY is honored when going from a asynchronous device (CSx) to a synchronous device (/SDCSy).

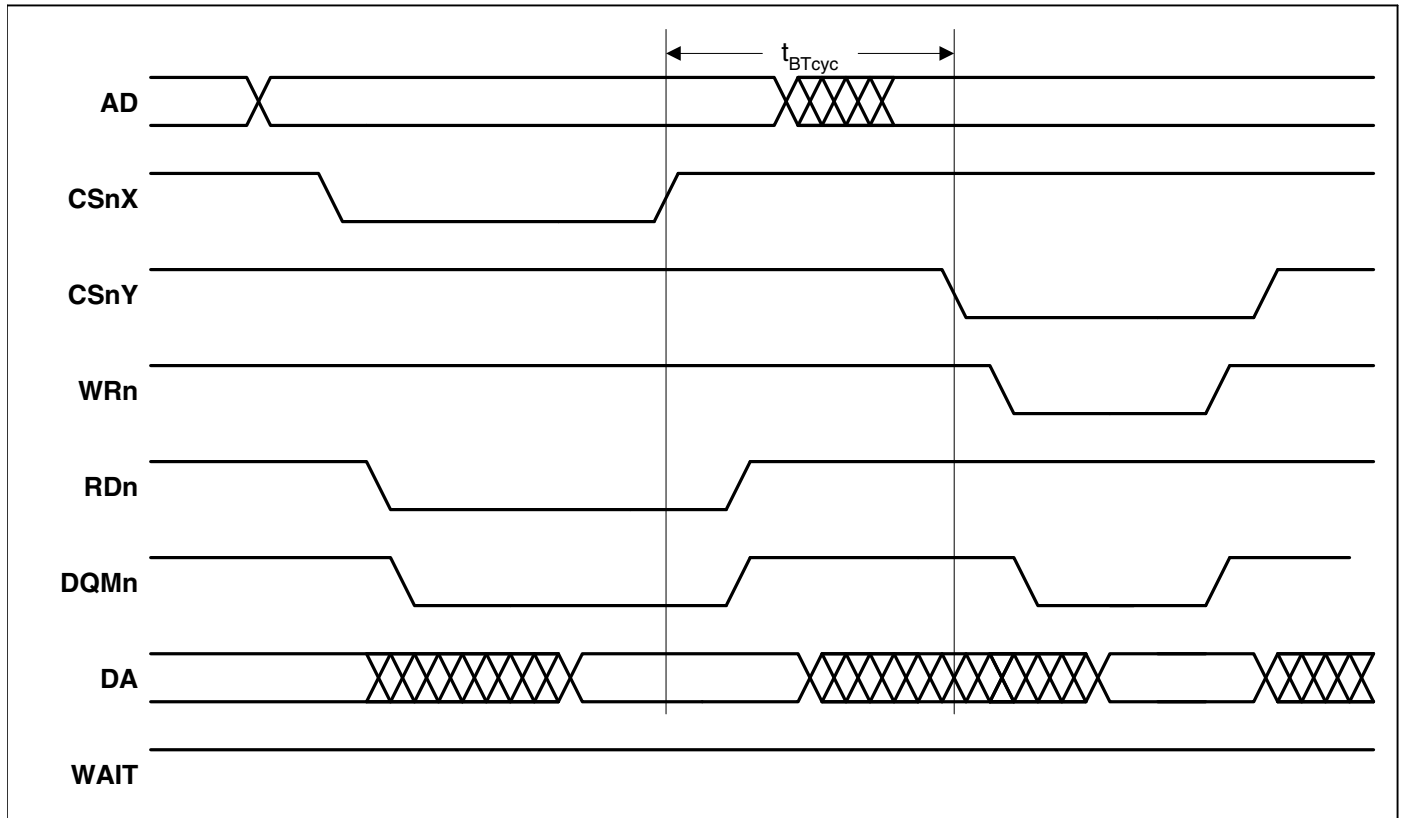

Figure 14. Static Memory Turnaround Cycle Timing Measurement

## Ethernet MAC Interface

Parameter	Symbol	Min		Typ		Max		Unit
		10 Mbit mode	100 Mbit mode	10 Mbit mode	100 Mbit mode	10 Mbit mode	100 Mbit mode	
TXCLK cycle time	$t_{TX\_per}$	-	-	400	40	-	-	ns
TXCLK high time	$t_{TX\_high}$	140	14	200	20	260	26	ns
TXCLK low time	$t_{TX\_low}$	140	14	200	20	260	26	ns
TXCLK to signal transition delay time	$t_{TXd}$	0	0	10	10	25	25	ns
TXCLK rise/fall time	$t_{TXrf}$	-	-	-	-	5	5	ns
RXCLK cycle time	$t_{RX\_per}$	-	-	400	40	-	-	ns
RXCLK high time	$t_{RX\_high}$	140	14	200	20	260	26	ns
RXCLK low time	$t_{RX\_low}$	140	14	200	20	260	26	ns
RXDVAL / RXERR setup time	$t_{RXs}$	10	10	-	-	-	-	ns
RXDVAL / RXERR hold time	$t_{RXh}$	10	10	-	-	-	-	ns
RXCLK rise/fall time	$t_{RXrf}$	-	-	-	-	5	5	ns
MDC cycle time	$t_{MDC\_per}$	-	-	400	400	-	-	ns
MDC high time	$t_{MDC\_high}$	160	160	-	-	-	-	ns
MDC low time	$t_{MDC\_low}$	160	160	-	-	-	-	ns
MDC rise/fall time	$t_{MDCrf}$	-	-	-	-	5	5	ns
MDIO setup time (STA sourced)	$t_{MDIOs}$	10	10	-	-	-	-	ns
MDIO hold time (STA sourced)	$t_{MDIOh}$	10	10	-	-	-	-	ns
MDC to MDIO signal transition delay time (PHY sourced)	$t_{MDIOd}$	-	-	-	-	300	300	ns

STA - Station - Any device that contains an IEEE 802.11 conforming Medium Access Control (MAC) and physical layer (PHY) interface to the wireless medium.

PHY - Ethernet physical layer interface.

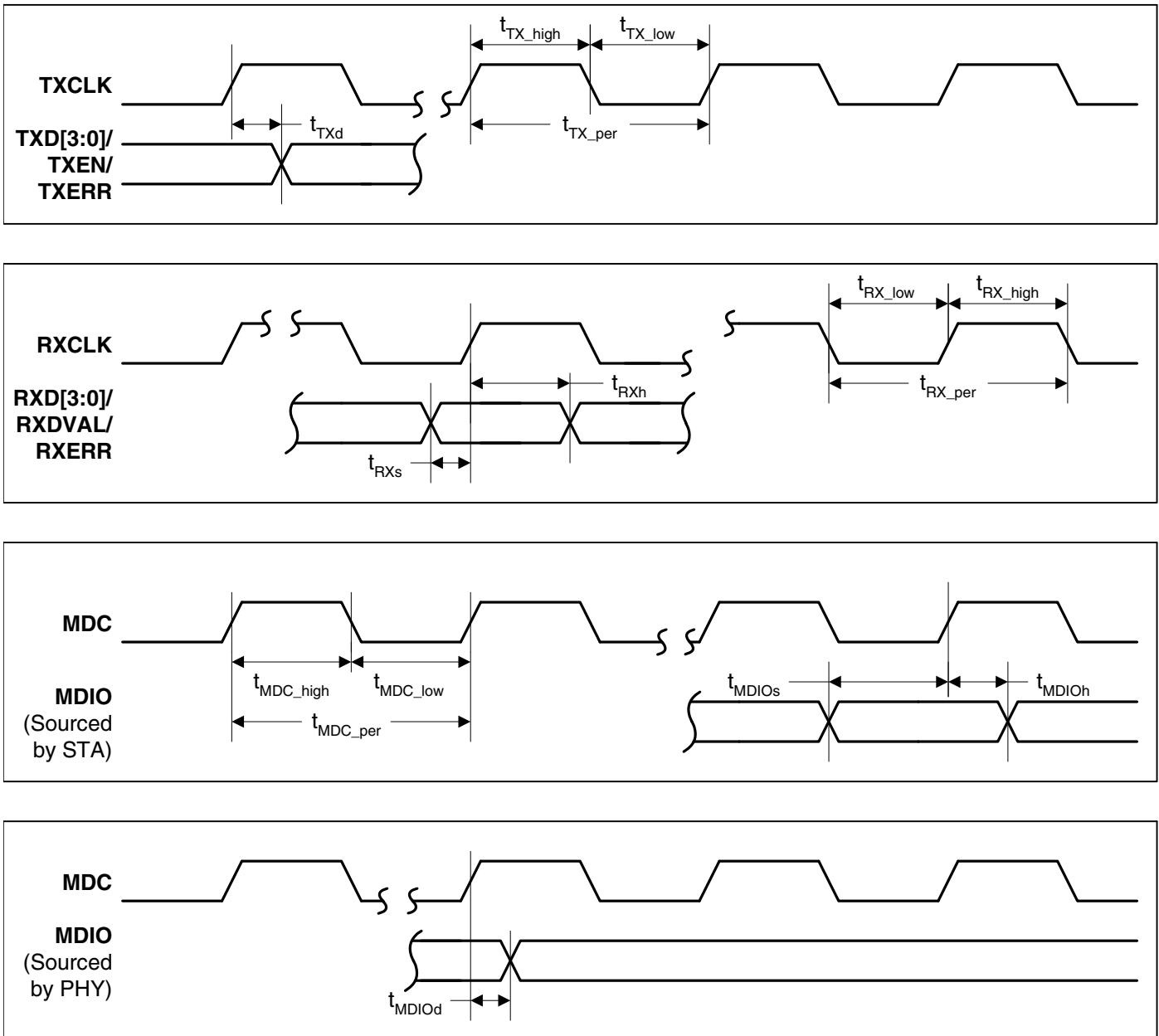

Figure 15. Ethernet MAC Timing Measurement

## Audio Interface

The following table contains the values for the timings of each of the SPI modes.

Parameter	Symbol	Min	Typ	Max	Unit
SCLK cycle time	$t_{clk\_per}$	-	$t_{spix\_clk}$	-	ns
SCLK high time	$t_{clk\_high}$	-	$(t_{spix\_clk}) / 2$	-	ns
SCLK low time	$t_{clk\_low}$	-	$(t_{spix\_clk}) / 2$	-	ns
SCLK rise/fall time	$t_{clkrf}$	1	-	8	ns
Data from master valid delay time	$t_{DMd}$	-	-	3	ns
Data from master setup time	$t_{DMs}$	20	-	-	ns
Data from master hold time	$t_{DMh}$	40	-	-	ns
Data from slave setup time	$t_{DSs}$	20	-	-	ns
Data from slave hold time	$t_{DSH}$	40	-	-	ns

Note: The  $t_{spix\_clk}$  is programmable by the user.

## Texas Instruments' Synchronous Serial Format

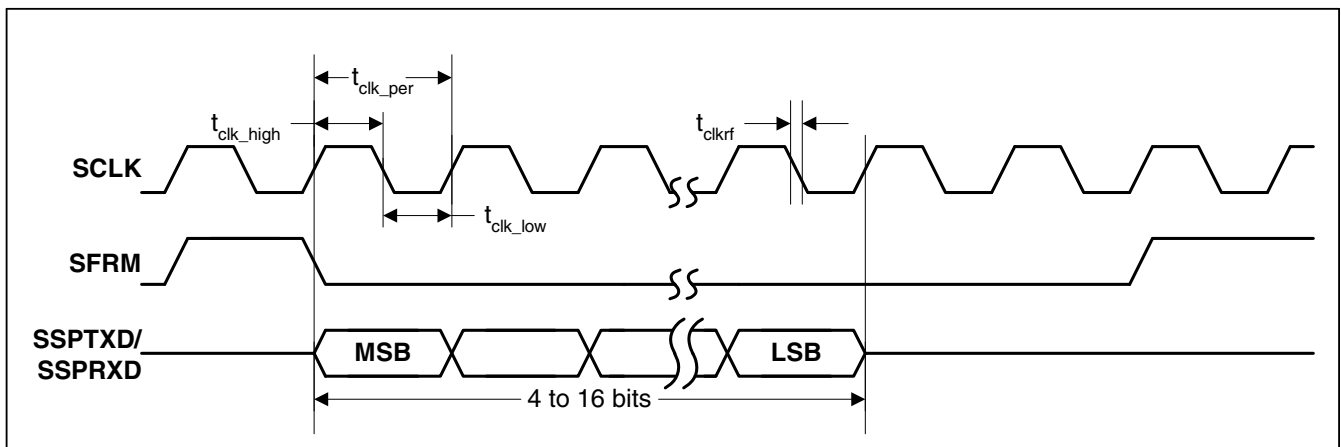

Figure 16. T/Single Transfer Timing Measurement

## Microwire

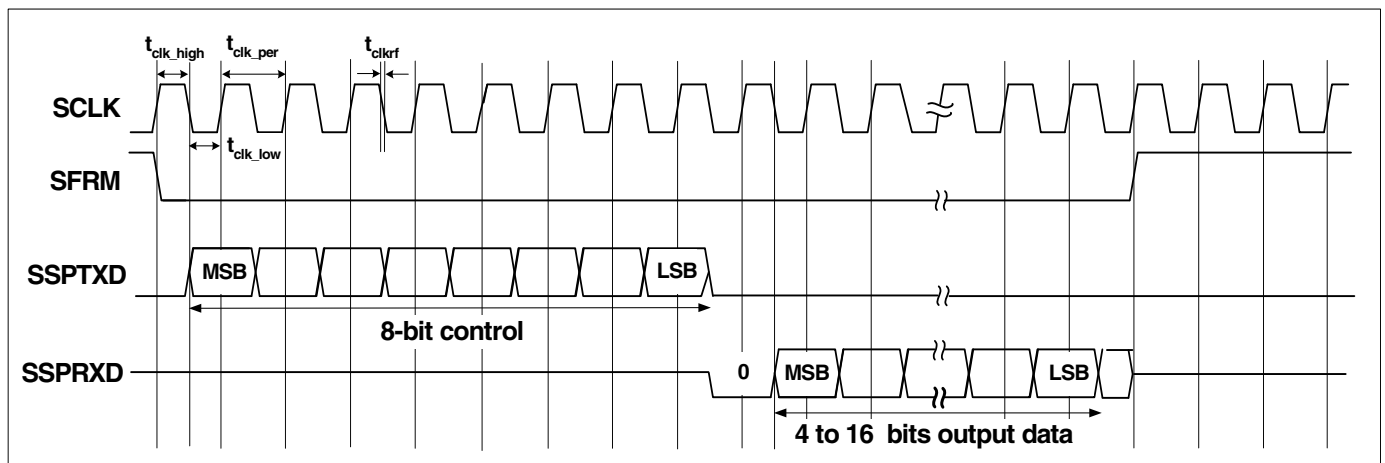

Figure 17. Microwire Frame Format, Single Transfer

**Motorola SPI**

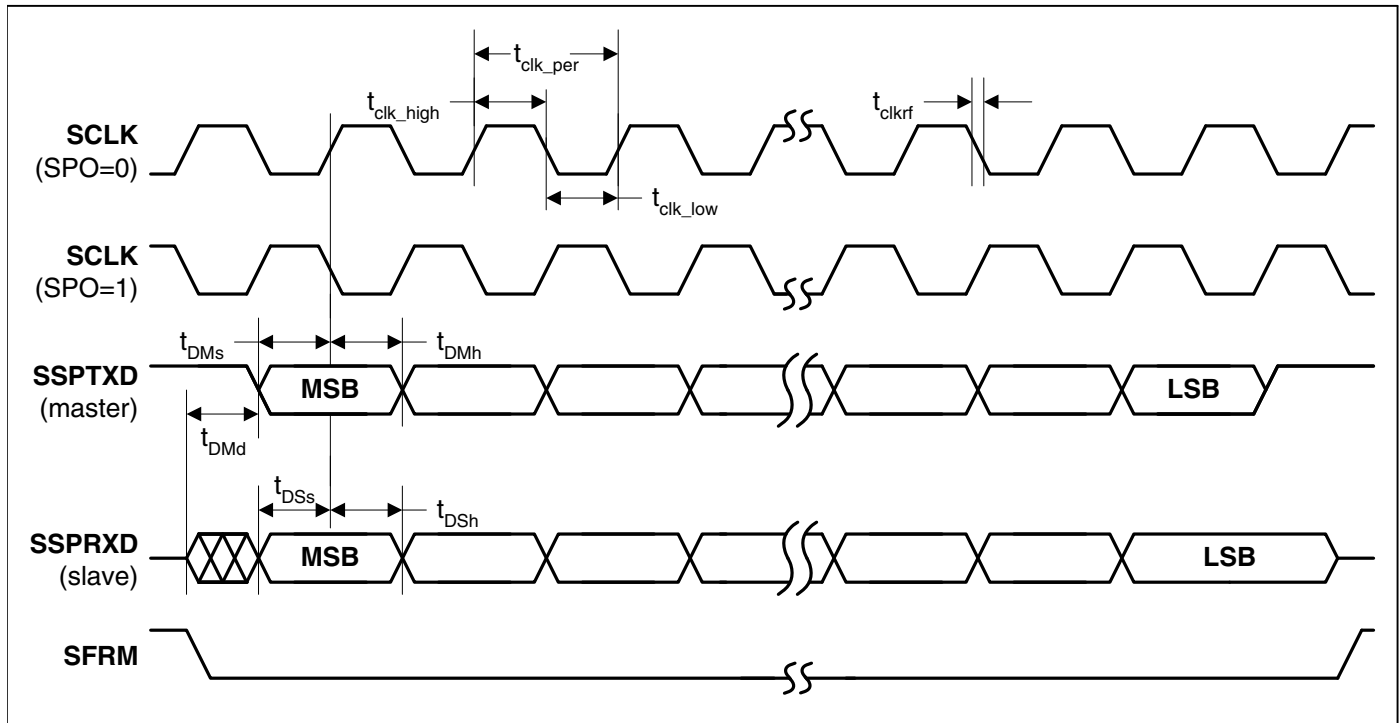

Figure 18. SPI Format with SPH=1 Timing Measurement

### Inter-IC Sound - I<sup>2</sup>S

Parameter	Symbol	Min	Typ	Max	Unit
SCLK cycle time	$t_{clk\_per}$	-	$t_{i2s\_clk}$	-	ns
SCLK high time	$t_{clk\_high}$	-	$(t_{i2s\_clk}) / 2$	-	ns
SCLK low time	$t_{clk\_low}$	-	$(t_{i2s\_clk}) / 2$	-	ns
SCLK rise/fall time	$t_{clkrf}$	1	4	8	ns
SCLK to LRCLK assert delay time	$t_{LRd}$	-	-	3	ns
Hold between SCLK assert then LRCLK deassert or Hold between LRCLK deassert then SCLK assert	$t_{LRh}$	0	-	-	ns
SDI to SCLK deassert setup time	$t_{SDIs}$	12	-	-	ns
SDI from SCLK deassert hold time	$t_{SDIh}$	0	-	-	ns
SCLK assert to SDO delay time	$t_{SDOd}$	-	-	9	ns
SDO from SCLK assert hold time	$t_{SDOh}$	1	-	-	ns

Note:  $t_{i2s\_clk}$  is programmable by the user.

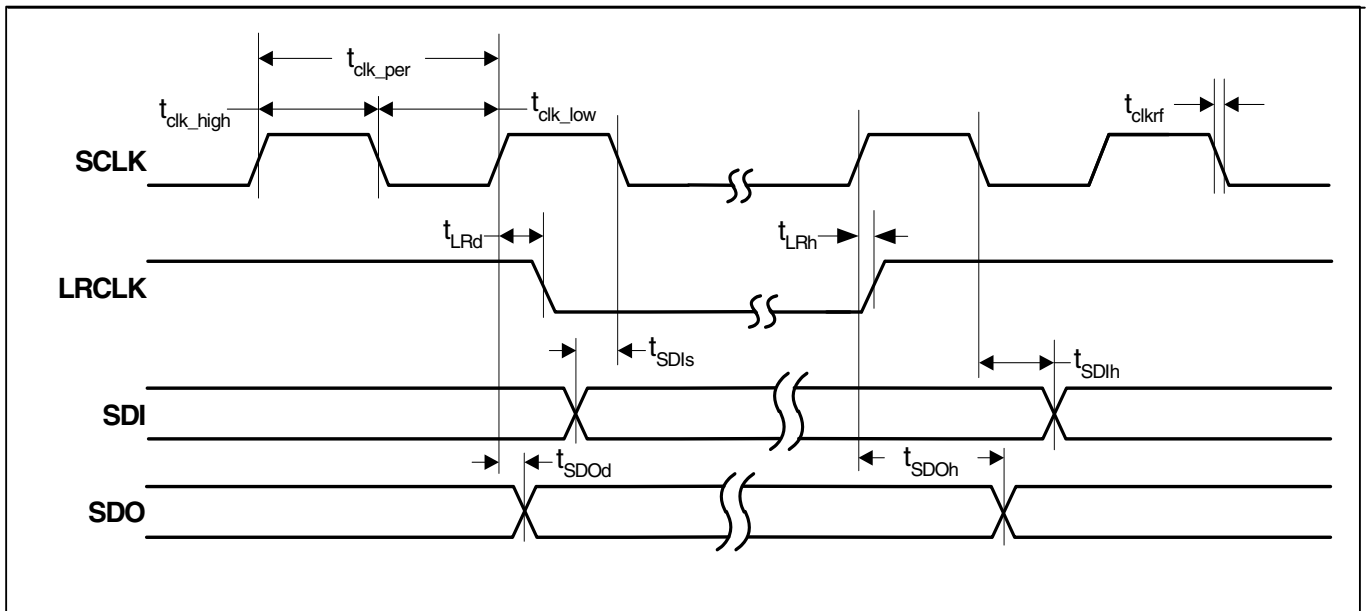

Figure 19. Inter-IC Sound (I<sup>2</sup>S) Timing Measurement

## AC'97

Parameter	Symbol	Min	Typ	Max	Unit
ABITCLK input cycle time	$t_{clk\_per}$	-	81.4	-	ns
ABITCLK input high time	$t_{clk\_high}$	36	-	45	ns
ABITCLK input low time	$t_{clk\_low}$	36	-	45	ns
ABITCLK input rise/fall time	$t_{clkrf}$	2	-	6	ns
ASDI setup to ABITCLK falling	$t_s$	10	-	-	ns
ASDI hold after ABITCLK falling	$t_h$	10	-	-	ns
ASDI input rise/fall time	$t_{rfin}$	2	-	6	ns
ABITCLK rising to ASDO / ASYNC valid, $C_L = 55$ pF	$t_{co}$	2	-	15	ns
ASYNC / ASDO rise/fall time, $C_L = 55$ pF	$t_{rfout}$	2	-	6	ns

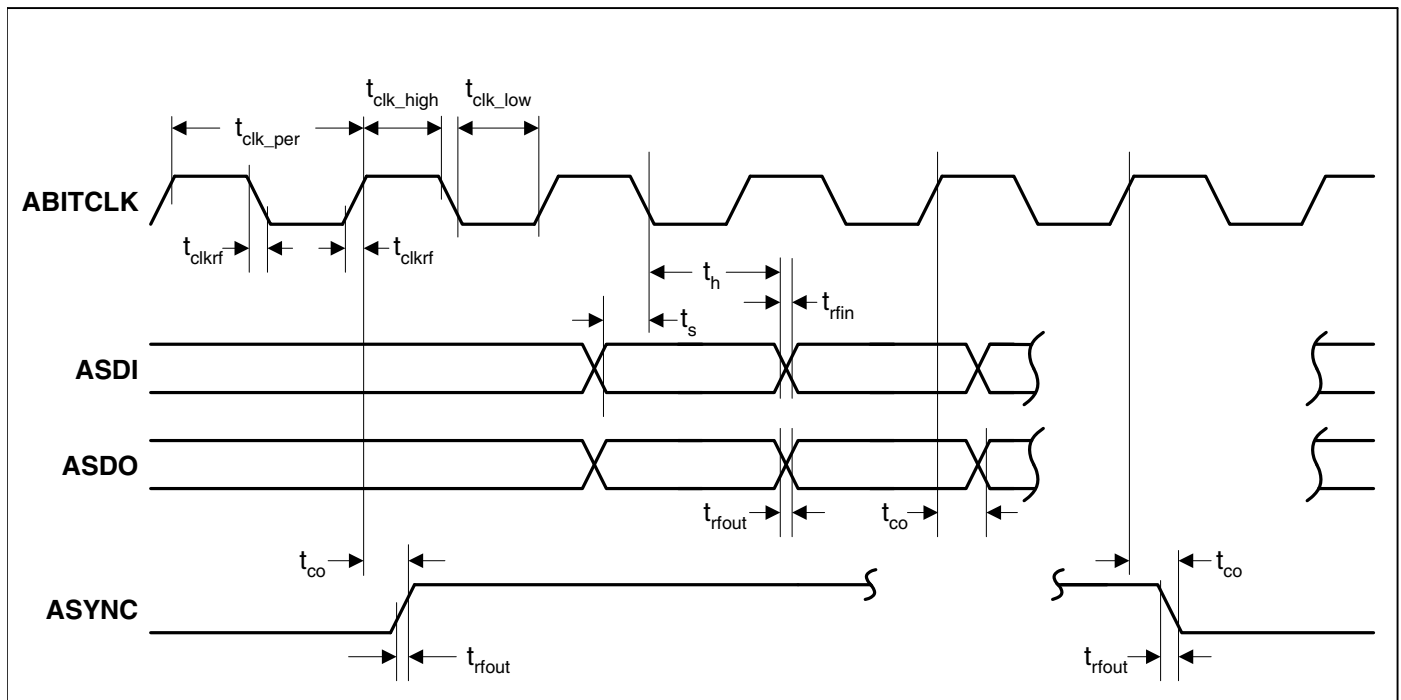

Figure 20. AC '97 Configuration Timing Measurement



## ADC

Parameter	Comment	Value	Units
Resolution	No missing codes Range of 0 to 3.3 V	50K counts (approximate)	
Integral non-linearity		0.01%	
Offset error		±15	mV
Full scale error		0.2%	
Maximum sample rate	ADIV = 0 ADIV = 1	3750 925	Samples per second Samples per second
Channel switch settling time	ADIV = 0 ADIV = 1	500 2	µs ms
Noise (RMS) - typical		120	µV

Note: ADIV refers to bit 16 in the KeyTchClkDiv register.  
 ADIV = 0 means the input clock to the ADC module is equal to the external 14.7456 MHz clock divided by 4.  
 ADIV = 1 means the input clock to the ADC module is equal to the external 14.7456 MHz clock divided by 16.

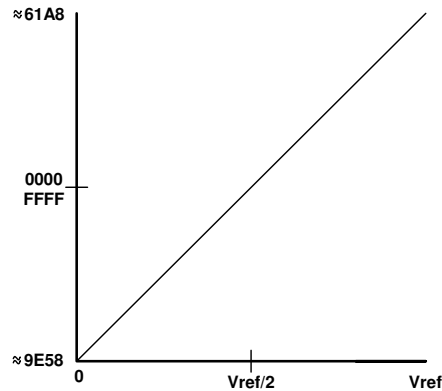

**A/D Converter Transfer Function**  
 (approximately ±25,000 counts)

**Figure 21. ADC Transfer Function**

Using the ADC:

This ADC has a state-machine based conversion engine that automates the conversion process. The initiator for a conversion is the read access of the TSXYResult register by the CPU. The data returned from reading this register contains the result as well as the status bit indicating the state of the ADC. However, this peripheral requires a delay between each successful conversion and the issue of the next conversion command, or else the returned value of successive samples may not reflect the analog input. Since the state of the ADC state machine is returned through the same channel used to initiate the conversion process, there must be a delay inserted after every complete conversion. Note that reading TSXYResult during a conversion will not affect the result of the ongoing process.

The following is a recommended procedure for safely polling the ADC from software:

1. Read the TSXYResult register into a local variable to initiate a conversion.
2. If the value of bit 31 of the local variable is '0' then repeat step 1.
3. Delay long enough to meet the maximum sample rate as shown above.
4. Mask the local variable with 0xFFFF to remove extraneous data.
5. If signed mode is used, do a sign extend of the lower halfword.
6. Return the sampled value.

## JTAG

Parameter	Symbol	Min	Max	Units
TCK clock period	$t_{clk\_per}$	100	-	ns
TCK clock high time	$t_{clk\_high}$	50	-	ns
TCK clock low time	$t_{clk\_low}$	50	-	ns
TMS / TDI to clock rising setup time	$t_{JP_s}$	20	-	ns
Clock rising to TMS / TDI hold time	$t_{JP_h}$	45	-	ns
JTAG port clock to output	$t_{JP_{co}}$	-	30	ns
JTAG port high impedance to valid output	$t_{JP_{zx}}$	-	30	ns
JTAG port valid output to high impedance	$t_{JP_{xz}}$	-	30	ns

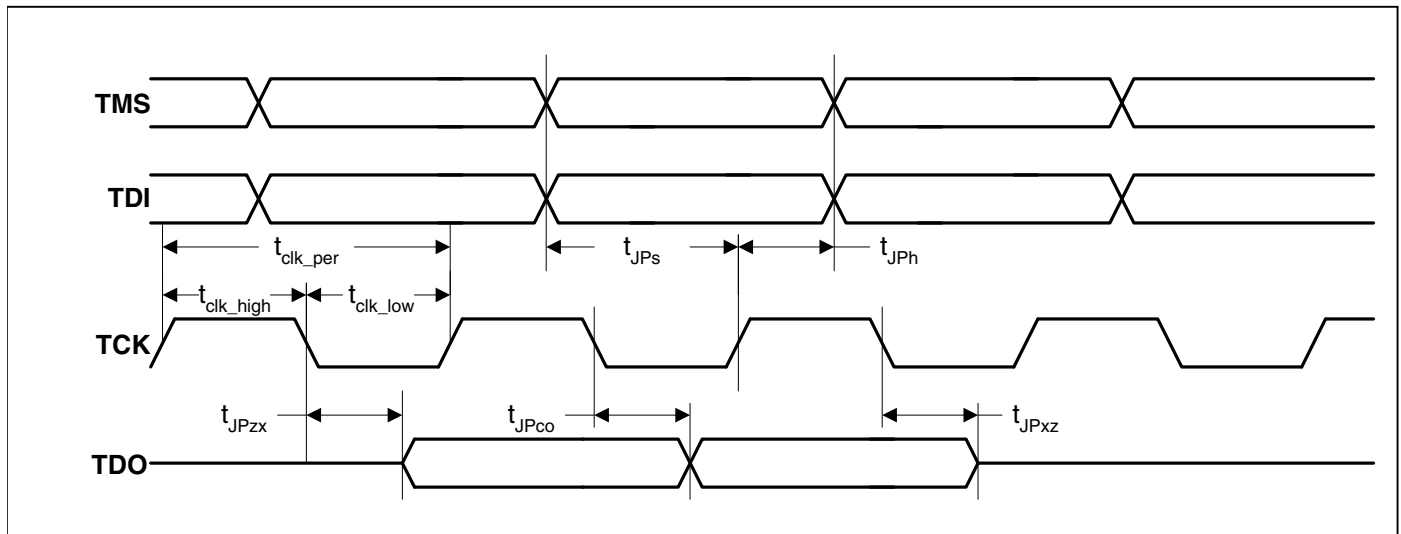
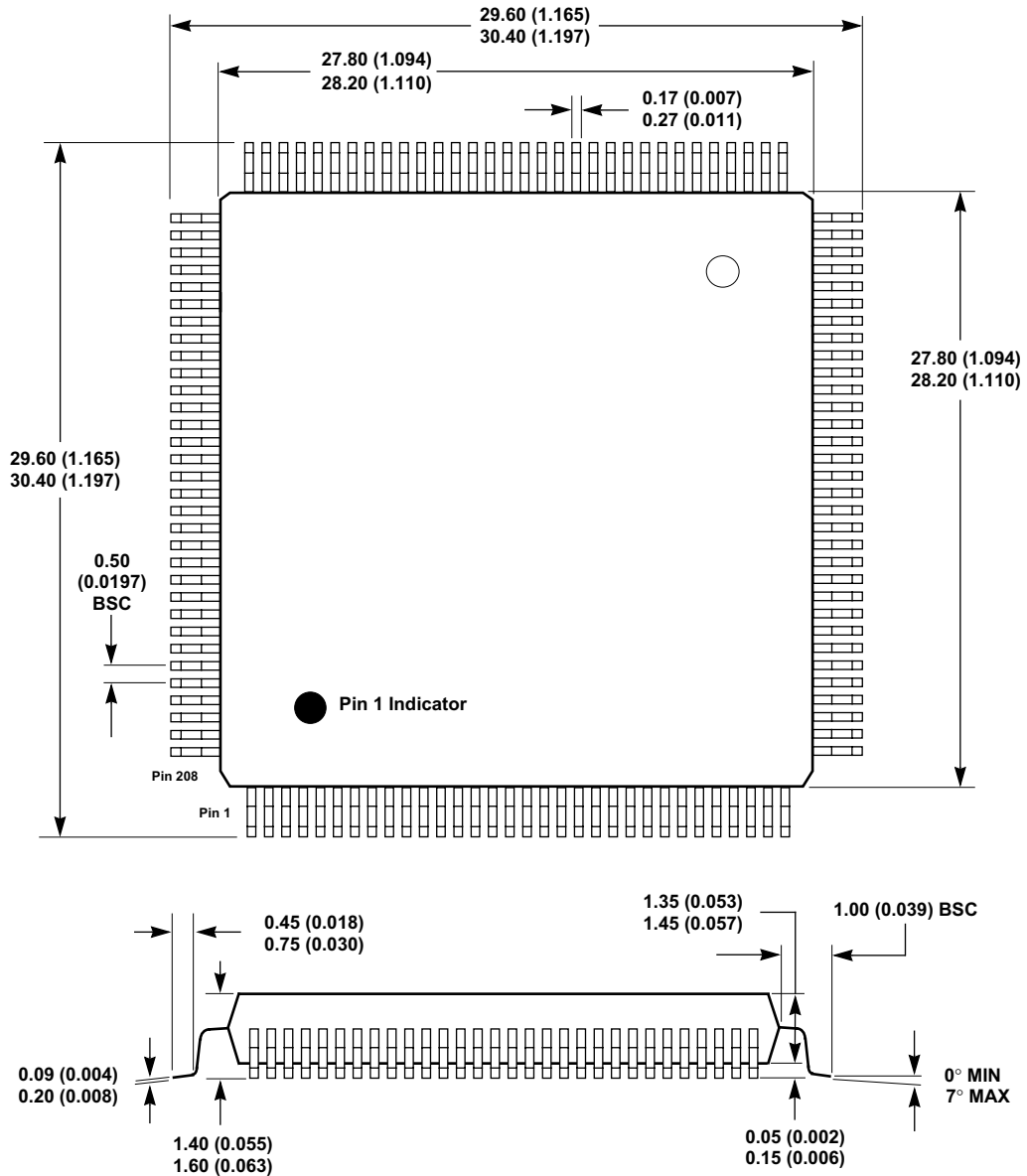

Figure 22. JTAG Timing Measurement

## 208 Pin LQFP Package Outline

### 208-Pin LQFP (28 × 28 × 1.40-mm Body)



#### NOTES:

- 1) Dimensions are in millimeters, and controlling dimension is millimeter.
- 2) Package body dimensions do not include mold protrusion, which is 0.25 mm (0.010 in).
- 3) Pin 1 identification may be either ink dot or dimple.
- 4) Package top dimensions can be smaller than bottom dimensions by 0.20 mm (0.008 in).
- 5) The 'lead width with plating' dimension does not include a total allowable dambar protrusion of 0.08 mm (at maximum material condition).
- 6) Ejector pin marks in molding are present on every package.
- 7) Drawing above does not reflect exact package pin count.

## 208 Pin LQFP Pinout

The following table shows the 208 pin LQFP pinout.

- VDD\_core is CVDD.
- VDD\_ring is RVDD.
- NC means that the pin is not connected.

## Pin List

The following Low-Profile Quad Flat Pack (LQFP) pin assignment table is sorted in order of pin.

Table P. Pin List in Numerical Order by Pin Number

Pin Number	Pin Name	Pin Number	Pin Name	Pin Number	Pin Name	Pin Number	Pin Name	Pin Number	Pin Name	Pin Number	Pin Name
1	CSn[7]	36	AD[5]	71	AD[9]	106	USBp[0]	141	EGPIO[10]	176	TXEN
2	CSn[6]	37	DA[12]	72	DA[1]	107	ABITCLK	142	EGPIO[9]	177	MIITXD[0]
3	CSn[3]	38	AD[4]	73	AD[8]	108	CTSn	143	EGPIO[8]	178	MIITXD[1]
4	CSn[2]	39	DA[11]	74	DA[0]	109	RXD[0]	144	EGPIO[7]	179	MIITXD[2]
5	CSn[1]	40	AD[3]	75	DSRn	110	RXD[1]	145	EGPIO[6]	180	MIITXD[3]
6	AD[25]	41	vdd_ring	76	DTRn	111	vdd_ring	146	EGPIO[5]	181	TXCLK
7	vdd_ring	42	gnd_ring	77	TCK	112	gnd_ring	147	EGPIO[4]	182	RXERR
8	gnd_ring	43	DA[10]	78	TDI	113	TXD[0]	148	EGPIO[3]	183	RXDVAL
9	AD[24]	44	AD[2]	79	TDO	114	TXD[1]	149	gnd_ring	184	MIIRXD[0]
10	SDCLK	45	DA[9]	80	TMS	115	CGPIO[0]	150	vdd_ring	185	MIIRXD[1]
11	AD[23]	46	AD[1]	81	vdd_ring	116	gnd_core	151	EGPIO[2]	186	MIIRXD[2]
12	vdd_core	47	DA[8]	82	gnd_ring	117	PLL_GND	152	EGPIO[1]	187	gnd_ring
13	gnd_core	48	AD[0]	83	BOOT[1]	118	XTALI	153	EGPIO[0]	188	vdd_ring
14	SDWEn	49	vdd_ring	84	BOOT[0]	119	XTALO	154	ARSTn	189	MIIRXD[3]
15	SDCSn[3]	50	gnd_ring	85	gnd_ring	120	PLL_VDD	155	TRSTn	190	RXCLK
16	SDCSn[2]	51	NC	86	NC	121	vdd_core	156	ASDI	191	MDIO
17	SDCSn[1]	52	NC	87	EECLK	122	gnd_ring	157	USBm[2]	192	MDC
18	SDCSn[0]	53	vdd_ring	88	EEDAT	123	vdd_ring	158	USBp[2]	193	RDn
19	vdd_ring	54	gnd_ring	89	ASYNC	124	RSTOn	159	WAITn	194	WRn
20	gnd_ring	55	AD[15]	90	vdd_core	125	PRSTn	160	EGPIO[15]	195	AD[16]
21	RASn	56	DA[7]	91	gnd_core	126	CSn[0]	161	gnd_ring	196	AD[17]
22	CASn	57	vdd_core	92	ASDO	127	gnd_core	162	vdd_ring	197	gnd_core
23	DQMn[1]	58	gnd_core	93	SCLK1	128	vdd_core	163	EGPIO[14]	198	vdd_core
24	DQMn[0]	59	AD[14]	94	SFRM1	129	gnd_ring	164	EGPIO[13]	199	HGPIO[2]
25	AD[22]	60	DA[6]	95	SSPRX1	130	vdd_ring	165	EGPIO[12]	200	HGPIO[3]
26	AD[21]	61	AD[13]	96	SSPTX1	131	ADC[4]	166	gnd_core	201	HGPIO[4]
27	vdd_ring	62	DA[5]	97	GRLED	132	ADC[3]	167	vdd_core	202	HGPIO[5]
28	gnd_ring	63	AD[12]	98	RDLED	133	ADC[2]	168	FGPIO[3]	203	gnd_ring
29	DA[15]	64	DA[4]	99	vdd_ring	134	ADC[1]	169	FGPIO[2]	204	vdd_ring
30	AD[7]	65	AD[11]	100	gnd_ring	135	ADC[0]	170	FGPIO[1]	205	AD[18]
31	DA[14]	66	vdd_ring	101	INT[3]	136	ADC_VDD	171	gnd_ring	206	AD[19]
32	AD[6]	67	gnd_ring	102	INT[1]	137	RTCXTALI	172	vdd_ring	207	AD[20]
33	DA[13]	68	DA[3]	103	INT[0]	138	RTCXTALO	173	CLD	208	SDCLKEN
34	vdd_core	69	AD[10]	104	RTSn	139	ADC_GND	174	CRS		
35	gnd_core	70	DA[2]	105	USBm[0]	140	EGPIO[11]	175	TXERR		

The following section focuses on the EP9301 pin signals from two viewpoints - the pin usage and pad characteristics, and the pin multiplexing usage. The first table ([Table Q](#)) is a summary of all the EP9301 pin signals. The second table ([Table R](#)) illustrates the pin signal multiplexing and configuration options.

[Table Q](#) is a summary of the EP9301 pin signals, which illustrates the pad type and pad pull type (if any). The symbols used in the table are defined as follows. (Note: A blank box means Not Applicable (NA) or, for Pull Type, No Pull (NP).)

Under the Pad Type column:

- A - Analog pad
- P - Power pad
- G - Ground pad
- I - Pin is an input only
- I/O - Pin is input/output
- 4mA - Pin is a 4mA output driver
- 8mA - Pin is an 8mA output driver
- 12mA - Pin is an 12mA output driver

See the text description for additional information about bi-directional pins.

Under the Pull Type Column:

- PU - Resistor is a pull up to the RVDD supply
- PD - Resistor is a pull down to the RGND supply

Table Q. Pin Description

Pin Name	Block	Pad Type	Pull Type	Description
TCK	JTAG	I	PD	JTAG clock in
TDI	JTAG	I	PD	JTAG data in
TDO	JTAG	4ma		JTAG data out
TMS	JTAG	I	PD	JTAG test mode select
TRSTn	JTAG	I	PD	JTAG reset
BOOT[1:0]	System	I	PD	Boot mode select in
XTALI	PLL	A		Main oscillator input
XTALO	PLL	A		Main oscillator output
VDD_PLL	PLL	P		Main oscillator power, 1.8V
GND_PLL	PLL	G		Main oscillator ground
RTCXTALI	RTC	A		RTC oscillator input
RTCXTALO	RTC	A		RTC oscillator output
WRn	EBUS	4ma		SRAM Write strobe out
RDn	EBUS	4ma		SRAM Read / OE strobe out
WAITn	EBUS	I	PU	SRAM Wait in
AD[25:0]	EBUS	8ma		Shared Address bus out
DA[15:0]	EBUS	8ma	PU	Shared Data bus in/out
CSn[3:0]	EBUS	4ma	PU	Chip select out
CSn[7:6]	EBUS	4ma	PU	Chip select out
DQMn[1:0]	EBUS	8ma		Shared data mask out
SDCLK	SDRAM	8ma		SDRAM clock out
SDCLKEN	SDRAM	8ma		SDRAM clock enable out
SDCSn[3:0]	SDRAM	4ma		SDRAM chip selects out
RASn	SDRAM	8ma		SDRAM RAS out
CASn	SDRAM	8ma		SDRAM CAS out
SDWEn	SDRAM	8ma		SDRAM write enable out
ADC[4:0]	ADC	A		External Analog Measurement Input
VDD_ADC	ADC	P		ADC power, 3.3V
GND_ADC	ADC	G		ADC ground
USBp[2, 0]	USB	A		USB positive signals
USBm[2, 0]	USB	A		USB negative signals
TXD0	UART1	4ma		Transmit out
RXD0	UART1	I	PU	Receive in
CTS <sub>n</sub>	UART1	I	PU	Clear to send / transmit enable
DSR <sub>n</sub>	UART1	I	PU	Data set ready / Data Carrier Detect
DTR <sub>n</sub>	UART1	4ma		Data Terminal Ready output
RTS <sub>n</sub>	UART1	4ma		Ready to send
TXD1	UART2	4ma		Transmit / IrDA output
RXD1	UART2	I	PU	Receive / IrDA input
MDC	EMAC	4ma		Management data clock
MDIO	EMAC	4ma	PU	Management data input/output
RXCLK	EMAC	I	PD	Receive clock in
MIIRXD[3:0]	EMAC	I	PD	Receive data in
RXDVAL	EMAC	I	PD	Receive data valid
RXERR	EMAC	I	PD	Receive data error
TXCLK	EMAC	I	PU	Transmit clock in
MIITXD[3:0]	EMAC	4ma	PD	Transmit data out

Table Q. Pin Description (Continued)

Pin Name	Block	Pad Type	Pull Type	Description
TXEN	EMAC	4ma	PD	Transmit enable
TXERR	EMAC	4ma	PD	Transmit error
CRS	EMAC	I	PD	Carrier sense
CLD	EMAC	I	PU	Collision detect
GRLED	LED	12ma		Green LED
RDLED	LED	12ma		Red LED
EECLK	EEPROM	4ma	PU	EEPROM / Two-wire Interface clock
EEDAT	EEPROM	4ma	PU	EEPROM / Two-wire Interface data
ABITCLK	AC97	8ma	PD	AC97 bit clock
ASYNC	AC97	8ma	PD	AC97 frame sync
ASDI	AC97	I	PD	AC97 Primary input
ASDO	AC97	8ma	PU	AC97 output
ARST <sub>n</sub>	AC97	8ma		AC97 reset
SCLK1	SPI1	I/O, 8ma	PD	SPI bit clock
SFRM1	SPI1	I/O, 8ma	PD	SPI Frame Clock
SSPRX1	SPI1	I	PD	SPI input
SSPTX1	SPI1	8ma		SPI output
INT[3], INT[1:0]	INT	I	PD	External interrupts
PRST <sub>n</sub>	Syscon	I	PU	Power on reset
RSTOn	Syscon	4ma		User Reset in out - open drain
EGPIO[15:0]	GPIO	I/O, 4ma	PU	Enhanced GPIO
FGPIO[3:1]	GPIO	I/O, 8ma	PU	GPIO on Port F
HGPIO[5:2]	GPIO	I/O, 8ma	PU	GPIO on Port H
CGPIO[0]	GPIO	I/O, 8ma	PU	GPIO on Port C
CVDD	Power	P		Digital power, 1.8V
RVDD	Power	P		Digital power, 3.3V
CGND	Ground	G		Digital ground
RGND	Ground	G		Digital ground

Table R illustrates the pin signal multiplexing and configuration options.

**Table R. Pin Multiplex Usage Information**

<b>Physical Pin Name</b>	<b>Description</b>	<b>Multiplex signal name</b>
EGPIO[0]	Ring Indicator Input	RI
EGPIO[1]	1Hz clock monitor	CLK1HZ
EGPIO[3]	HDLC Clock	HDLCCLK1
EGPIO[4]	I2S Transmit Data 1	SDO1
EGPIO[5]	I2S Receive Data 1	SDI1
EGPIO[6]	I2S Transmit Data 2	SDO2
EGPIO[7]	DMA Request 0	DREQ0
EGPIO[8]	DMA Acknowledge 0	DACK0
EGPIO[9]	DMA EOT 0	DEOT0
EGPIO[10]	DMA Request 1	DREQ1
EGPIO[11]	DMA Acknowledge 1	DACK1
EGPIO[12]	DMA EOT 1	DEOT1
EGPIO[13]	I2S Receive Data 2	SDI2
EGPIO[14]	PWM1 Output	PWMOUT1
EGPIO[15]	Device active / present	DASP
ABITCLK	I2S Serial clock	SCLK
ASYNC	I2S Frame Clock	LRCK
ASDO	I2S Transmit Data 0	SDO0
ASDI	I2S Receive Data 0	SDI0
ARSTn	I2S Master clock	MCLK
SCLK1	I2S Serial clock	SCLK
SFRM1	I2S Frame Clock	LRCK
SSPTX1	I2S Transmit Data 0	SDO0
SSPRX1	I2S Receive Data 0	SDI0

## Acronyms and Abbreviations

The following tables list abbreviations and acronyms used in this data sheet.

Term	Definition
ADC	Analog-to-Digital Converter
ALT	Alternative
AMBA	Advanced Micro-controller Bus Architecture
ATAPI	ATA Packet Interface
CODEC	COder / DECoder
CRC	Cyclic Redundancy Check
DAC	Digital-to-Analog Converter
DMA	Direct-Memory Access
EEPROM	Electrically Erasable Programmable Read Only Memory
EMAC	Ethernet Media Access Controller
EBUS	External Memory Bus
FIFO	First In / First Out
FIQ	Fast Interrupt Request
FLASH	Flash memory
GPIO	General Purpose I/O
HDLC	High-level Data Link Control
I/F	Interface
I <sup>2</sup> S	Inter-IC Sound
IC	Integrated Circuit
ICE	In-Circuit Emulator
IDE	Integrated Drive Electronics
IEEE	Institute of Electronics and Electrical Engineers
IrDA	Infrared Data Association
IRQ	Standard Interrupt Request
ISO	International Standards Organization
JTAG	Joint Test Action Group
LFSR	Linear Feedback Shift Register
MII	Media Independent Interface
MMU	Memory Management Unit

Term	Definition
OHCI	Open Host Controller Interface
PHY	Ethernet PHYSical layer interface
PIO	Programmed I/O
RISC	Reduced Instruction Set Computer
SDMI	Secure Digital Music Initiative
SDRAM	Synchronous Dynamic RAM
SPI	Serial Peripheral Interface
SRAM	Static Random Access Memory
STA	Station - Any device that contains an IEEE 802.11 conforming Medium Access Control (MAC) and physical layer (PHY) interface to the wireless medium
TFT	Thin Film Transistor
TLB	Translation Lookaside Buffer
USB	Universal Serial Bus

## Units of Measurement

Symbol	Unit of Measure
°C	degree Celsius
Hz	Hertz = cycle per second
kbps	Kilobits per second
kbyte	Kilobyte
KHz	KiloHertz = 1000 Hz
Mbps	Megabits per second
MHz	MegaHertz = 1,000 KiloHertz
μA	microAmpere = 10 <sup>-6</sup> Ampere
μs	microsecond = 1,000 nanoseconds = 10 <sup>-6</sup> seconds
mA	milliAmpere = 10 <sup>-3</sup> Ampere
ms	millisecond = 1,000 microseconds = 10 <sup>-3</sup> seconds
mW	milliWatt = 10 <sup>-3</sup> Watts
ns	nanosecond = 10 <sup>-9</sup> seconds
pF	picoFarad = 10 <sup>-12</sup> Farads
V	Volt
W	Watt



## ORDERING INFORMATION

The order numbers for the device are:

EP9301-CQZ	0°C to +70°C	208-pin LQFP	Lead Free
EP9301-IQZ	-40°C to +85°C	208-pin LQFP	Lead Free

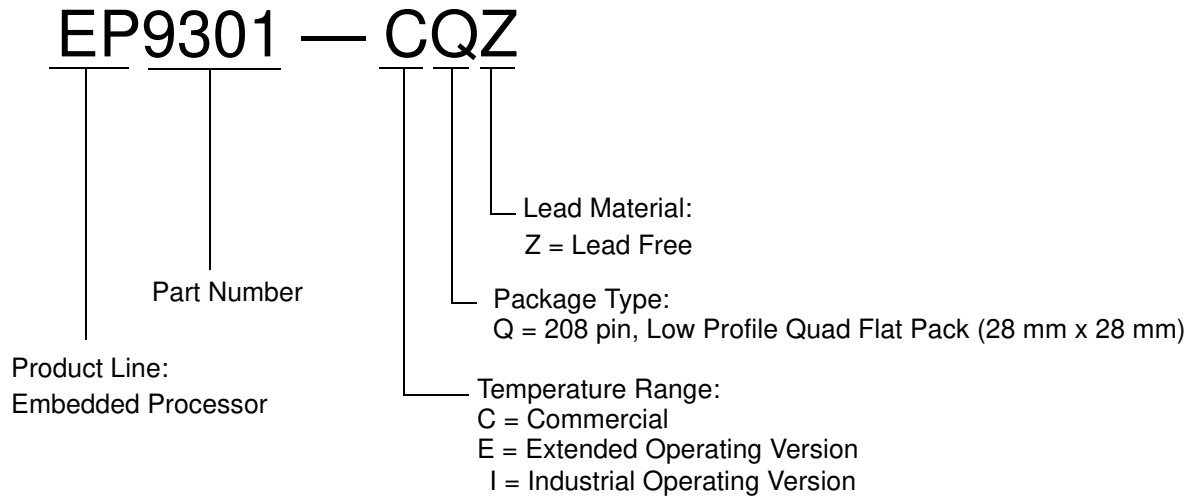

*Note: Go to the Cirrus Logic Internet site at <http://www.cirrus.com> to find contact information for your local sales representative.*

---

## Contacting Cirrus Logic Support

For all product questions and inquiries contact a Cirrus Logic Sales Representative.  
To find one nearest you go to [www.cirrus.com](http://www.cirrus.com)

---

### IMPORTANT NOTICE

Cirrus Logic, Inc. and its subsidiaries ("Cirrus") believe that the information contained in this document is accurate and reliable. However, the information is subject to change without notice and is provided "AS IS" without warranty of any kind (express or implied). Customers are advised to obtain the latest version of relevant information to verify, before placing orders, that information being relied on is current and complete. All products are sold subject to the terms and conditions of sale supplied at the time of order acknowledgment, including those pertaining to warranty, indemnification, and limitation of liability. No responsibility is assumed by Cirrus for the use of this information, including use of this information as the basis for manufacture or sale of any items, or for infringement of patents or other rights of third parties. This document is the property of Cirrus and by furnishing this information, Cirrus grants no license, express or implied under any patents, mask work rights, copyrights, trademarks, trade secrets or other intellectual property rights. Cirrus owns the copyrights associated with the information contained herein and gives consent for copies to be made of the information only for use within your organization with respect to Cirrus integrated circuits or other products of Cirrus. This consent does not extend to other copying such as copying for general distribution, advertising or promotional purposes, or for creating any work for resale.

CERTAIN APPLICATIONS USING SEMICONDUCTOR PRODUCTS MAY INVOLVE POTENTIAL RISKS OF DEATH, PERSONAL INJURY, OR SEVERE PROPERTY OR ENVIRONMENTAL DAMAGE ("CRITICAL APPLICATIONS"). CIRRUS PRODUCTS ARE NOT DESIGNED, AUTHORIZED OR WARRANTED FOR USE IN PRODUCTS SURGICALLY IMPLANTED INTO THE BODY, AUTOMOTIVE SAFETY OR SECURITY DEVICES, LIFE SUPPORT PRODUCTS OR OTHER CRITICAL APPLICATIONS. INCLUSION OF CIRRUS PRODUCTS IN SUCH APPLICATIONS IS UNDERSTOOD TO BE FULLY AT THE CUSTOMER'S RISK AND CIRRUS DISCLAIMS AND MAKES NO WARRANTY, EXPRESS, STATUTORY OR IMPLIED, INCLUDING THE IMPLIED WARRANTIES OF MERCHANTABILITY AND FITNESS FOR PARTICULAR PURPOSE, WITH REGARD TO ANY CIRRUS PRODUCT THAT IS USED IN SUCH A MANNER. IF THE CUSTOMER OR CUSTOMER'S CUSTOMER USES OR PERMITS THE USE OF CIRRUS PRODUCTS IN CRITICAL APPLICATIONS, CUSTOMER AGREES, BY SUCH USE, TO FULLY INDEMNIFY CIRRUS, ITS OFFICERS, DIRECTORS, EMPLOYEES, DISTRIBUTORS AND OTHER AGENTS FROM ANY AND ALL LIABILITY, INCLUDING ATTORNEYS' FEES AND COSTS, THAT MAY RESULT FROM OR ARISE IN CONNECTION WITH THESE USES.

Cirrus Logic, Cirrus, MaverickCrunch, MaverickKey, and the Cirrus Logic logo designs are trademarks of Cirrus Logic, Inc. All other brand and product names in this document may be trademarks or service marks of their respective owners.

Microsoft and Windows are registered trademarks of Microsoft Corporation.

Microwire is a trademark of National Semiconductor Corp. National Semiconductor is a registered trademark of National Semiconductor Corp.

Texas Instruments is a registered trademark of Texas Instruments, Inc.

Motorola and SPI are registered trademarks of Motorola, Inc.

LINUX is a registered trademark of Linus Torvalds.