

TwinDie 1.35V Automotive DDR3L SDRAM

MT41K512M16 – 64 Meg x 16 x 8 Banks

Description

The 8Gb (TwinDie) DDR3L SDRAM (1.35V) uses two Micron 4Gb DDR3L SDRAM x8 die for a 2 byte x16 device in one package. Refer to Micron's 4Gb DDR3L SDRAM data sheet (x8 option) for specifications not included in this document, specifications for base part number MT41K512M8 correlate to TwinDie manufacturing base part number MT41K512M16.

Features

- Uses two x8, 4Gb Micron die to make one x16 package
 - Single rank TwinDie
 - One external ZQ ball and one internal ZQ connected to V_{SSQ} through an embedded serial resistor
- $V_{DD} = V_{DDQ} = 1.35V$ (1.283–1.45V)
- Backward compatible to $V_{DD} = V_{DDQ} = 1.5V \pm 0.075V$
- Differential bidirectional data strobe
- 8n-bit prefetch architecture
- Differential clock inputs (CK, CK#)
- 8 internal banks
- Nominal and dynamic on-die termination (ODT) for data, strobe, and mask signals
- Programmable CAS (READ) latency (CL)
- Programmable posted CAS additive latency (AL)
- Programmable CAS (WRITE) latency (CWL)
- Fixed burst length (BL) of 8 and burst chop (BC) of 4 (via the mode register set [MRS])
- Selectable BC4 or BL8 on-the-fly (OTF)
- Self refresh mode
- T_C of $-40^\circ C$ to $+105^\circ C$
 - 64ms, 8192-cycle refresh at $-40^\circ C$ to $+85^\circ C$
 - 32ms at $+85^\circ C$ to $+105^\circ C$
- Self refresh temperature (SRT)
- Automatic self refresh (ASR)
- Write leveling
- Multipurpose register
- Output driver calibration
- AEC-Q100
- PPAP submission
- 8D response time

Options

- Configuration
 - 512 Meg x 16
- TFBGA package (Pb-free) – x16
 - 96-ball (8mm x 14mm) - SAC302
 - 96-ball (8mm x 14mm) - SAC Q
- Timing – cycle time
 - 1.07ns @ CL = 13 (DDR3-1866)
- Product certification
 - Automotive
- Operating temperature
 - Industrial ($-40^\circ C \leq T_C \leq +95^\circ C$)
 - Automotive ($-40^\circ C \leq T_C \leq +105^\circ C$)
- Revision

Marking

512M16	
VRN	
VRP	
-107	
A	
IT	
AT	
:P	

Note: 1. Not all options listed can be combined to define an offered product. Use the part catalog search on <http://www.micron.com> for available offerings.

Table 1: Key Timing Parameters

Speed Grade	Data Rate (MT/s)	Target t_{RCD} - t_{RP} -CL	t_{RCD} (ns)	t_{RP} (ns)	CL (ns)
-107	1866	13-13-13	13.91	13.91	13.91

Table 2: Addressing

Parameter	512 Meg x 16
Configuration	64 Meg x 8 x 8 banks x 2 die
Die per package	2
Refresh count	8K
Row address	64K (A[15:0])
Bank address	8 (BA[2:0])
Column address	1K (A[9:0])
Page size per die	1KB

Figure 1: DDR3L Part Numbers

Example Part Number: MT41K512M16VRP-107 AAT:P

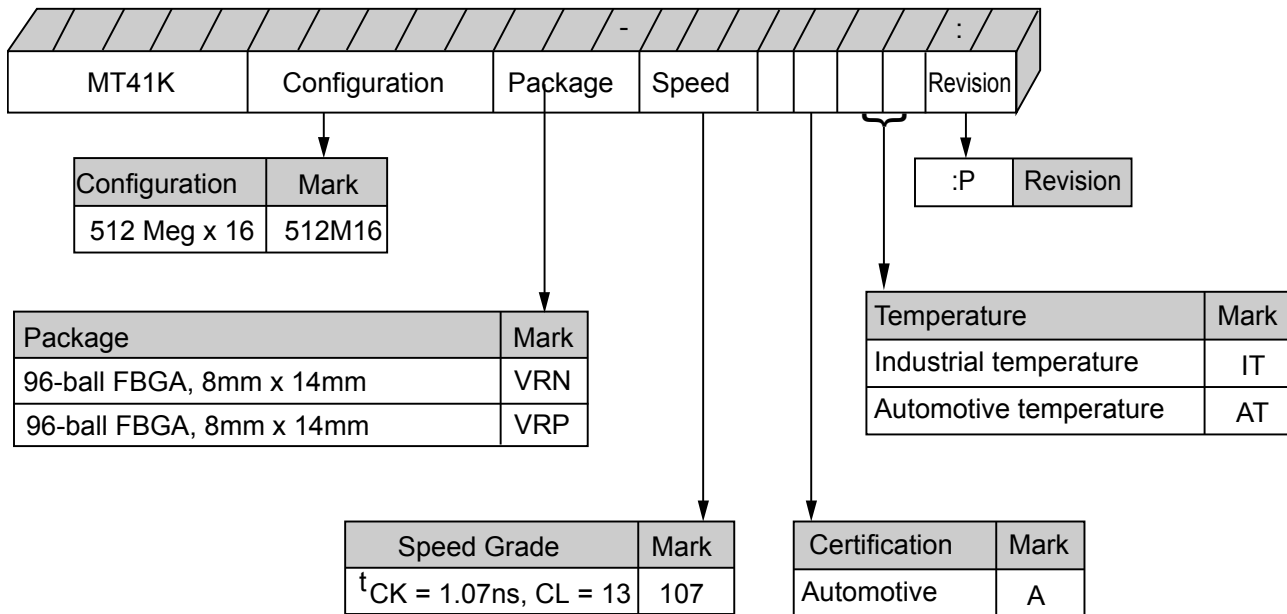

Note: 1. Not all options listed can be combined to define an offered product. Use the part catalog search on <http://www.micron.com> for available offerings.



FBGA Part Marking Decoder

Due to space limitations, FBGA-packaged components have an abbreviated part marking that is different from the part number. For a quick conversion of an FBGA code, see the FBGA Part Marking Decoder on Micron's Web site: <http://www.micron.com>.

Important Notes and Warnings

Micron Technology, Inc. ("Micron") reserves the right to make changes to information published in this document, including without limitation specifications and product descriptions. This document supersedes and replaces all information supplied prior to the publication hereof. You may not rely on any information set forth in this document if you obtain the product described herein from any unauthorized distributor or other source not authorized by Micron.

Automotive Applications. Products are not designed or intended for use in automotive applications unless specifically designated by Micron as automotive-grade by their respective data sheets. Distributor and customer/distributor shall assume the sole risk and liability for and shall indemnify and hold Micron harmless against all claims, costs, damages, and expenses and reasonable attorneys' fees arising out of, directly or indirectly, any claim of product liability, personal injury, death, or property damage resulting directly or indirectly from any use of non-automotive-grade products in automotive applications. Customer/distributor shall ensure that the terms and conditions of sale between customer/distributor and any customer of distributor/customer (1) state that Micron products are not designed or intended for use in automotive applications unless specifically designated by Micron as automotive-grade by their respective data sheets and (2) require such customer of distributor/customer to indemnify and hold Micron harmless against all claims, costs, damages, and expenses and reasonable attorneys' fees arising out of, directly or indirectly, any claim of product liability, personal injury, death, or property damage resulting from any use of non-automotive-grade products in automotive applications.

Critical Applications. Products are not authorized for use in applications in which failure of the Micron component could result, directly or indirectly in death, personal injury, or severe property or environmental damage ("Critical Applications"). Customer must protect against death, personal injury, and severe property and environmental damage by incorporating safety design measures into customer's applications to ensure that failure of the Micron component will not result in such harms. Should customer or distributor purchase, use, or sell any Micron component for any critical application, customer and distributor shall indemnify and hold harmless Micron and its subsidiaries, subcontractors, and affiliates and the directors, officers, and employees of each against all claims, costs, damages, and expenses and reasonable attorneys' fees arising out of, directly or indirectly, any claim of product liability, personal injury, or death arising in any way out of such critical application, whether or not Micron or its subsidiaries, subcontractors, or affiliates were negligent in the design, manufacture, or warning of the Micron product.

Customer Responsibility. Customers are responsible for the design, manufacture, and operation of their systems, applications, and products using Micron products. ALL SEMICONDUCTOR PRODUCTS HAVE INHERENT FAILURE RATES AND LIMITED USEFUL LIVES. IT IS THE CUSTOMER'S SOLE RESPONSIBILITY TO DETERMINE WHETHER THE MICRON PRODUCT IS SUITABLE AND FIT FOR THE CUSTOMER'S SYSTEM, APPLICATION, OR PRODUCT. Customers must ensure that adequate design, manufacturing, and operating safeguards are included in customer's applications and products to eliminate the risk that personal injury, death, or severe property or environmental damages will result from failure of any semiconductor component.

Limited Warranty. In no event shall Micron be liable for any indirect, incidental, punitive, special or consequential damages (including without limitation lost profits, lost savings, business interruption, costs related to the removal or replacement of any products or rework charges) whether or not such damages are based on tort, warranty, breach of contract or other legal theory, unless explicitly stated in a written agreement executed by Micron's duly authorized representative.

Functional Description

The TwinDie DDR3L SDRAM is a high-speed, CMOS dynamic random access memory device internally configured as two 8-bank DDR3L SDRAM devices.

Although each die is tested individually within the dual-die package, some TwinDie test results may vary from a like die tested within a monolithic die package.

The DDR3L SDRAM uses a double data rate architecture to achieve high-speed operation. The double data rate architecture is an $8n$ -prefetch architecture with an interface designed to transfer two data words per clock cycle at the I/O balls. A single read or write access consists of a single $8n$ -bit-wide, one-clock-cycle data transfer at the internal DRAM core and eight corresponding n -bit-wide, one-half-clock-cycle data transfers at the I/O balls.

The differential data strobe (DQS, DQS#) is transmitted externally, along with data, for use in data capture at the DDR3L SDRAM input receiver. DQS is center-aligned with data for WRITES. The read data is transmitted by the DDR3L SDRAM and edge-aligned to the data strobes.

The DDR3 SDRAM operates from a differential clock (CK and CK#). The crossing of CK going HIGH and CK# going LOW is referred to as the positive edge of CK. Control, command, and address signals are registered at every positive edge of CK. Input data is registered on the first rising edge of DQS after the WRITE preamble, and output data is referenced on the first rising edge of DQS after the READ preamble.

Read and write accesses to the DDR3L SDRAM are burst-oriented. Accesses start at a selected location and continue for a programmed number of locations in a programmed sequence. Accesses begin with the registration of an ACTIVATE command, which is then followed by a READ or WRITE command. The address bits registered coincident with the ACTIVATE command are used to select the bank and row to be accessed. The address bits (including CS n #, BA n , and A n) registered coincident with the READ or WRITE command are used to select the rank, bank, and starting column location for the burst access.

This data sheet provides a general description, package dimensions, and the package ballout. Refer to the Micron monolithic DDR3L data sheet for complete information regarding individual die initialization, register definition, command descriptions, and die operation.

Ball Assignments and Descriptions

Figure 2: 96-Ball FBGA – x16 (Top View)

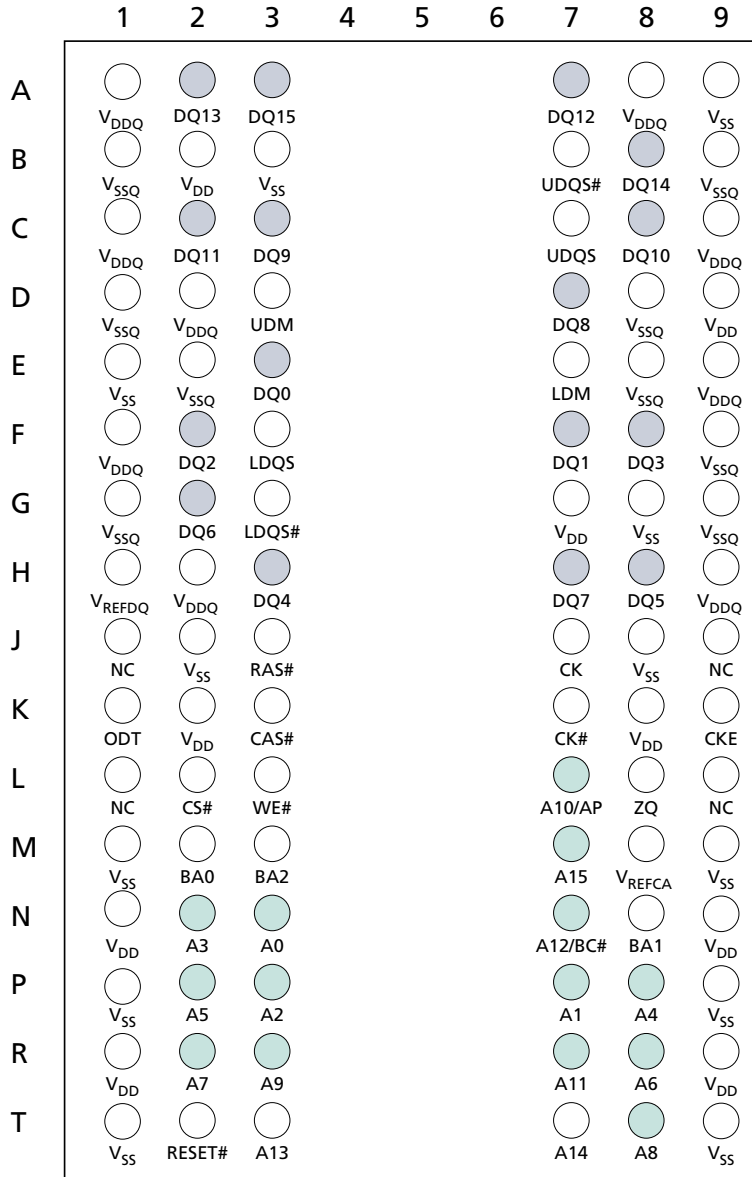

- Notes:
- Ball descriptions listed in Table 3 are listed as “x4, x8” if unique; otherwise, x4 and x8 are the same.
 - A comma separates the configuration; a slash defines a selectable function.
Example D7 = NF, NF/TDQS#. NF applies to the x4 configuration only. NF/TDQS# applies to the x8 configuration only—selectable between NF or TDQS# via MRS (symbols are defined in Table 3).

Table 3: 96-Ball FBGA – x16 Ball Descriptions

Symbol	Type	Description
A[15:13], A12/BC#, A11, A10/AP, A[9:0]	Input	Address inputs: Provide the row address for ACTIVATE commands, and the column address and auto precharge bit (A10) for READ/WRITE commands, to select one location out of the memory array in the respective bank. A10 sampled during a PRECHARGE command determines whether the PRECHARGE applies to one bank (A10 LOW, bank selected by BA[2:0]) or all banks (A10 HIGH). The address inputs also provide the op-code during a LOAD MODE command. Address inputs are referenced to V_{REFCA} . A12/BC#: When enabled in the mode register (MR), A12 is sampled during READ and WRITE commands to determine whether burst chop (on-the-fly) will be performed (HIGH = BL8 or no burst chop, LOW = BC4). See the Truth Table – Command section.
BA[2:0]	Input	Bank address inputs: BA[2:0] define the bank to which an ACTIVATE, READ, WRITE, or PRECHARGE command is being applied. BA[2:0] define which mode register (MR0, MR1, MR2, or MR3) is loaded during the LOAD MODE command. BA[2:0] are referenced to V_{REFCA} .
CK, CK#	Input	Clock: CK and CK# are differential clock inputs. All control and address input signals are sampled on the crossing of the positive edge of CK and the negative edge of CK#. Output data strobe (DQS, DQS#) is referenced to the crossings of CK and CK#.
CKE	Input	Clock enable: CKE enables (registered HIGH) and disables (registered LOW) internal circuitry and clocks on the DRAM. The specific circuitry that is enabled/disabled is dependent upon the DDR3 SDRAM configuration and operating mode. Taking CKE LOW provides PRECHARGE POWER-DOWN and SELF REFRESH operations (all banks idle), or active power-down (row active in any bank). CKE is synchronous for power-down entry and exit and for self refresh entry. CKE is asynchronous for self refresh exit. Input buffers (excluding CK, CK#, CKE, RESET#, and ODT) are disabled during POWER-DOWN. Input buffers (excluding CKE and RESET#) are disabled during SELF REFRESH. CKE is referenced to V_{REFCA} .
CS#	Input	Chip select: CS# enables (registered LOW) and disables (registered HIGH) the command decoder. All commands are masked when CS# is registered HIGH. CS# provides for external rank selection on systems with multiple ranks. CS# is considered part of the command code. CS# is referenced to V_{REFCA} .
LDM	Input	Input data mask: LDM is a lower-byte, input mask signal for write data. Lower-byte input data is masked when LDM is sampled HIGH along with the input data during a write access. Although the LDM ball is input-only, the LDM loading is designed to match that of the DQ and DQS balls. LDM is referenced to V_{REFDQ} .
ODT	Input	On-die termination: ODT enables (registered HIGH) and disables (registered LOW) termination resistance internal to the DDR3 SDRAM. When enabled in normal operation, ODT is only applied to each of the following balls: DQ[15:0], LDQS, LDQS#, UDQS, UDQS#, LDM, and UDM for the x16; DQ0[7:0], DQS, DQS#, DM/TDQS, and NF/TDQS# (when TDQS is enabled) for the x8; DQ[3:0], DQS, DQS#, and DM for the x4. The ODT input is ignored if disabled via the LOAD MODE command. ODT is referenced to V_{REFCA} .
RAS#, CAS#, WE#	Input	Command inputs: RAS#, CAS#, and WE# (along with CS#) define the command being entered and are referenced to V_{REFCA} .

Table 3: 96-Ball FBGA – x16 Ball Descriptions (Continued)

Symbol	Type	Description
RESET#	Input	Reset: RESET# is an active LOW CMOS input referenced to V_{SS} . The RESET# input receiver is a CMOS input defined as a rail-to-rail signal with DC HIGH $\geq 0.8 \times V_{DD}$ and DC LOW $\leq 0.2 \times V_{DDQ}$. RESET# assertion and desertion are asynchronous.
UDM	Input	Input data mask: UDM is an upper-byte, input mask signal for write data. Upper-byte input data is masked when UDM is sampled HIGH along with that input data during a WRITE access. Although the UDM ball is input-only, the UDM loading is designed to match that of the DQ and DQS balls. UDM is referenced to V_{REFDQ} .
DQ[7:0]	I/O	Data input/output: Lower byte of bidirectional data bus for the x16 configuration. DQ[7:0] are referenced to V_{REFDQ} .
DQ[15:8]	I/O	Data input/output: Upper byte of bidirectional data bus for the x16 configuration. DQ[15:8] are referenced to V_{REFDQ} .
LDQS, LDQS#	I/O	Lower byte data strobe: Output with read data. Edge-aligned with read data. Input with write data. Center-aligned to write data.
UDQS, UDQS#	I/O	Upper byte data strobe: Output with read data. Edge-aligned with read data. Input with write data. DQS is center-aligned to write data.
V_{DD}	Supply	Power supply: 1.35V (1.283–1.45V) / 1.5V $\pm 0.075V$ (backward compatible).
V_{DDQ}	Supply	DQ power supply: 1.35V (1.283–1.45V) / 1.5V $\pm 0.075V$ (backward compatible). Isolated on the device for improved noise immunity.
V_{REFCA}	Supply	Reference voltage for control, command, and address: V_{REFCA} must be maintained at all times (including self refresh) for proper device operation.
V_{REFDQ}	Supply	Reference voltage for data: V_{REFDQ} must be maintained at all times (excluding self refresh) for proper device operation.
V_{SS}	Supply	Ground.
V_{SSQ}	Supply	DQ ground: Isolated on the device for improved noise immunity.
ZQ	Reference	External reference ball for output drive calibration: This ball is tied to an external 240 Ω resistor (RZQ), which is tied to V_{SSQ} .
NC	–	No connect: These balls should be left unconnected (the ball has no connection to the DRAM or to other balls).

Package Dimensions

Figure 3: 96-Ball FBGA – x16

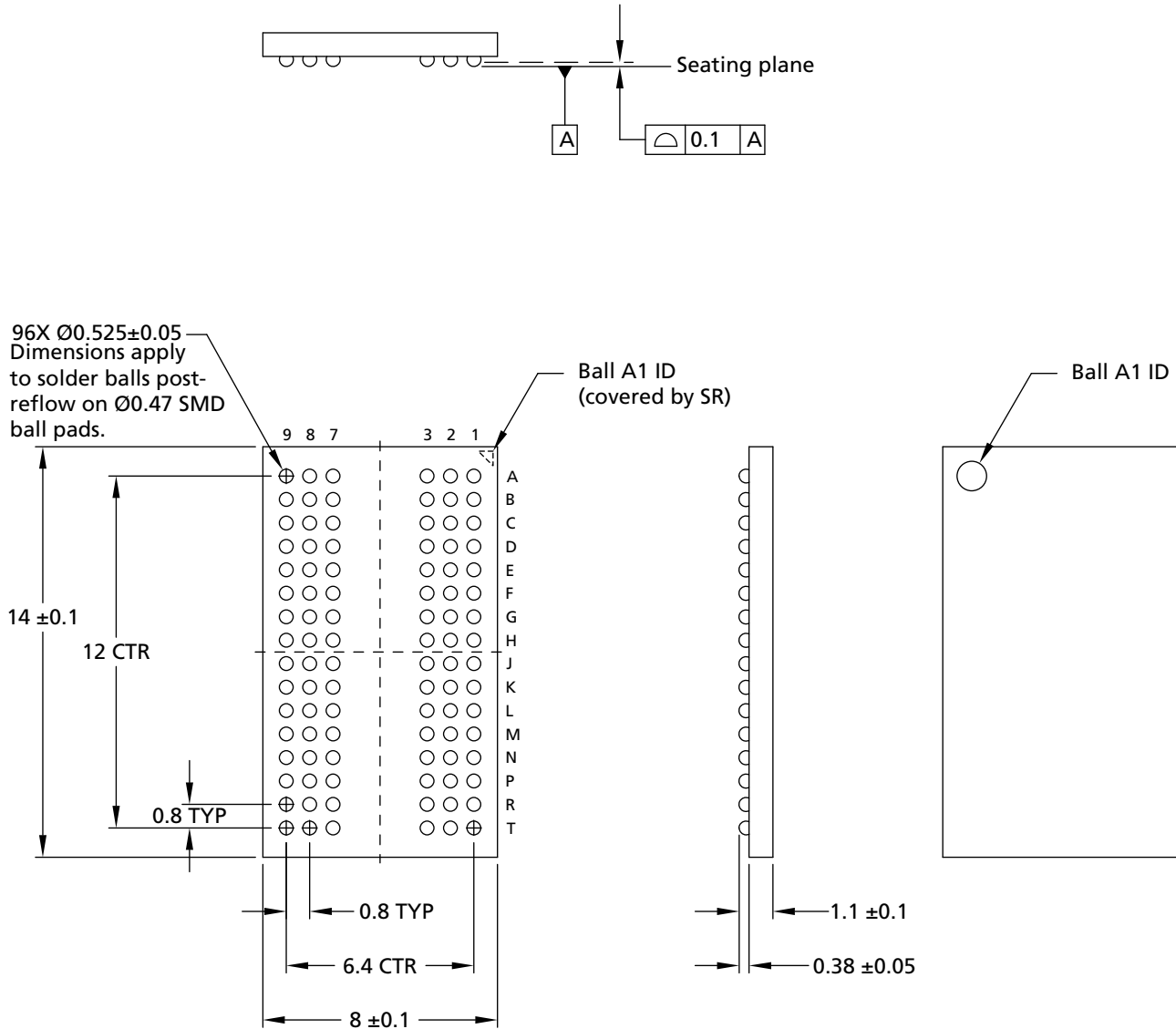

- Notes:
1. All dimensions are in millimeters.
 2. VRN material composition: Pb-free SAC302 (96.8% Sn, 3% Ag, 0.2% Cu) .
 3. VRP material composition: Pb-free SAC Q (92.45% Sn, 4% Ag, 0.5% Cu, 3% Bi, 0.05% Ni) .

Functional Block Diagram

Figure 4: Functional Block Diagram (512Meg x 16)

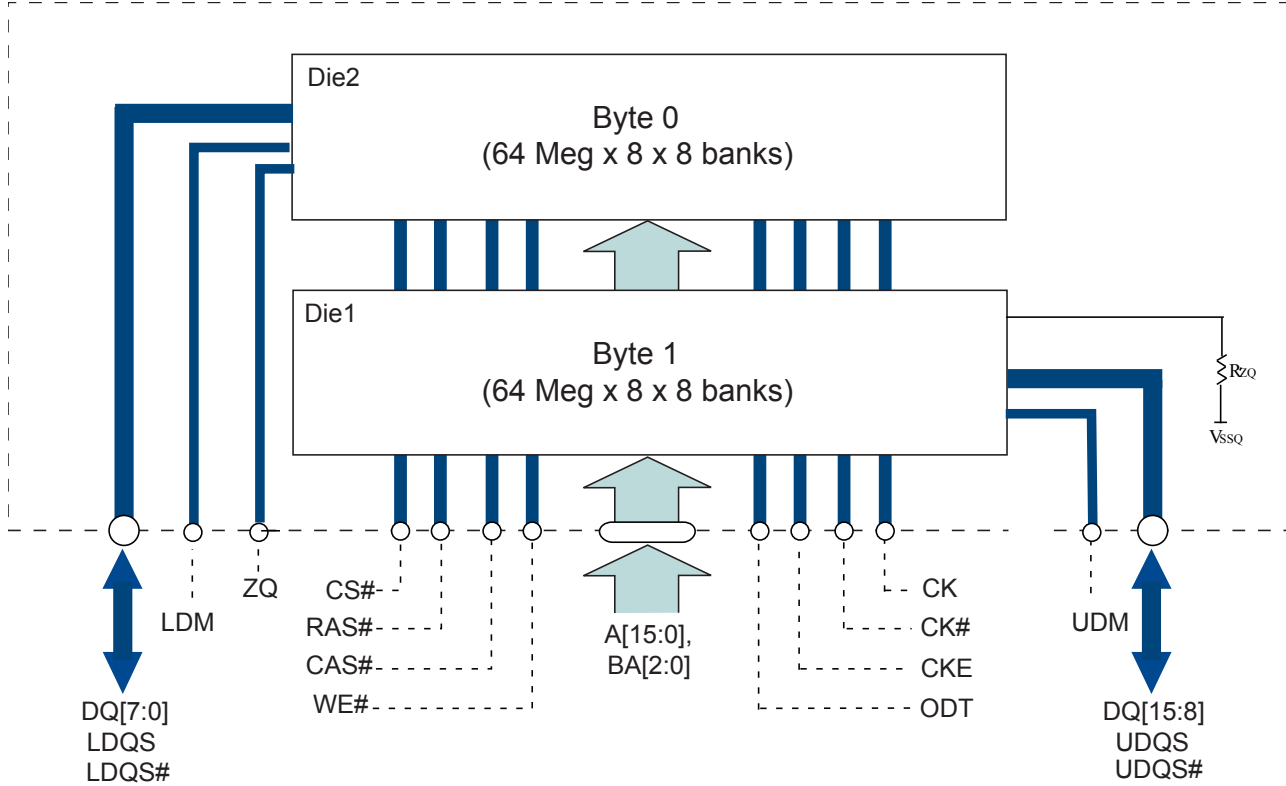

Thermal Characteristics

Table 4: Thermal Characteristics

Notes 1–3 apply to entire table

Parameter	Symbol	Value	Units	Notes
Operating case temperature – Industrial	T_C	-40 to +95	°C	1, 2, 3, 4
Operating case temperature – Automotive	T_C	-40 to +105	°C	1, 2, 3, 4

- Notes:
1. MAX operating case temperature T_C is measured in the center of the package, as shown below.
 2. A thermal solution must be designed to ensure that the device does not exceed the maximum T_C during operation.
 3. Device functionality is not guaranteed if the device exceeds maximum T_C during operation.
 4. If T_C exceeds 85°C, the DRAM must be refreshed externally at 2x refresh, which is a 3.9µs interval refresh rate. The use of SRT or ASR must be enabled.

Figure 5: Thermal Measurement Point

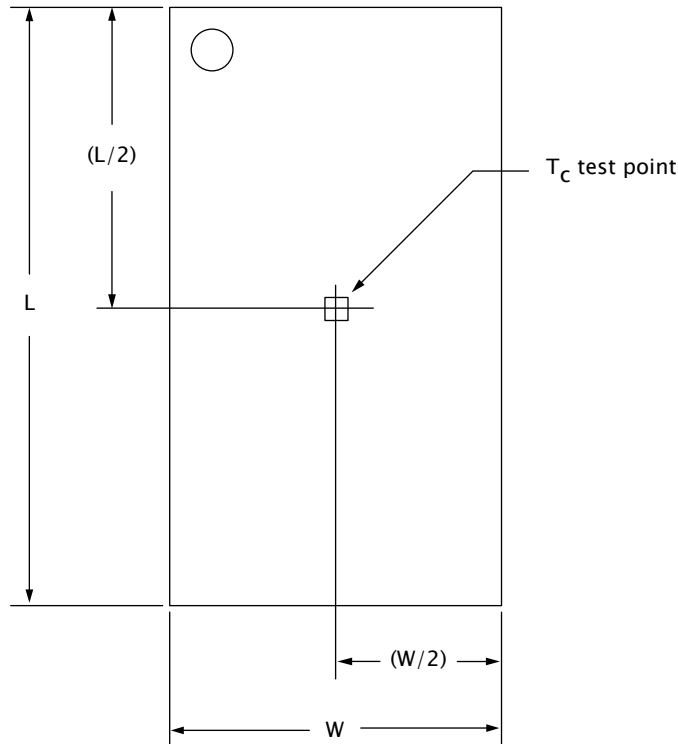

Table 5: Thermal Impedance

Die Rev.	Package	Substrate	Θ_{JA} ($^{\circ}C/W$)			Θ_{JB} ($^{\circ}C/W$)	Θ_{JC} ($^{\circ}C/W$)
			Airflow = 0m/s	Airflow = 1m/s	Airflow = 2m/s		
P	96-ball (VRN and VRP)	Low conductivity	52.2	41.1	36.7	N/A	4.9
		High conductivity	33.9	28.7	26.9	19.0	N/A

Note: 1. Thermal resistance data is based on a number of samples from multiple lots and should be viewed as a typical number.

Electrical Specifications

Absolute Ratings

Stresses greater than those listed may cause permanent damage to the device. This is a stress rating only, and functional operation of the device at these or any other conditions outside those indicated in the operational sections of this specification is not implied. Exposure to absolute maximum rating conditions for extended periods may adversely affect reliability.

Table 6: Absolute Maximum Ratings

Symbol	Parameter	Min	Max	Unit	Notes
V_{DD}	V_{DD} supply voltage relative to V_{SS}	-0.4	1.975	V	1
V_{DDQ}	V_{DDQ} supply voltage relative to V_{SSQ}	-0.4	1.975	V	
V_{IN}, V_{OUT}	Voltage on any pin relative to V_{SS}	-0.4	1.975	V	
T_C	Operating case temperature – Commercial	0	95	°C	2, 3
	Operating case temperature – Industrial	-40	95	°C	2, 3
	Operating case temperature – Automotive	-40	105	°C	2, 3
T_{STG}	Storage temperature	-55	150	°C	

- Notes:
- V_{DD} and V_{DDQ} must be within 300mV of each other at all times, and V_{REF} must not be greater than $0.6 \times V_{DDQ}$. When V_{DD} and V_{DDQ} are <500mV, V_{REF} can be ≤ 300 mV.
 - MAX operating case temperature. T_C is measured in the center of the package.
 - Device functionality is not guaranteed if the DRAM device exceeds the maximum T_C during operation.
 - Ultra-high temperature use based on automotive usage model. Please contact Micron sales representative if you have questions.

Input/Output Capacitance

Table 7: DDR3L Input/Output Capacitance

Note 1 applies to the entire table

Capacitance Parameters	Sym	DDR3L -1866		Unit	Notes
		Min	Max		
CK and CK#	C_{CK}	2.4	4.0	pF	
ΔC : CK to CK#	C_{DCK}	0.0	0.3	pF	
Single-end I/O: DQ, DM	C_{IO}	2.8	4.2	pF	2
Differential I/O: DQS, DQS#, TDQS, TDQS#	C_{IO}	2.8	4.2	pF	3
ΔC : DQS to DQS#, TDQS, TDQS#	C_{DDQS}	0.0	0.3	pF	3
ΔC : DQ to DQS	C_{DIO}	-1.0	0.6	pF	4
Inputs (CTRL, CMD, ADDR)	C_I	2.4	4.6	pF	5
ΔC : CTRL to CK	C_{DI_CTRL}	-0.8	0.8	pF	6
ΔC : CMD_ADDR to CK	$C_{DI_CMD_ADDR}$	-0.8	0.8	pF	7
ZQ pin capacitance	C_{ZQ}	-	6.1	pF	
Reset pin capacitance	C_{RE}	-	6.0	pF	

- Notes:
- $V_{DD} = 1.35V$ (1.283–1.45V), $V_{DDQ} = V_{DD}$, $V_{REF} = V_{SS}$, $f = 100$ MHz, $T_C = 25^\circ C$. $V_{OUT(DC)} = 0.5 \times V_{DDQ}$, $V_{OUT} = 0.1V$ (peak-to-peak).
 - DM input is grouped with I/O pins, reflecting the fact that they are matched in loading.
 - Includes TDQS, TDQS#. C_{DDQS} is for DQS vs. DQS# and TDQS vs. TDQS# separately.
 - $C_{DIO} = C_{IO(DQ)} - 0.5 \times (C_{IO(DQS)} + C_{IO(DQS\#)})$.
 - Excludes CK, CK#; CTRL = ODT, CS#, and CKE; CMD = RAS#, CAS#, and WE#; ADDR = A[n:0], BA[2:0].
 - $C_{DI_CTRL} = C_{I(CTRL)} - 0.5 \times (C_{CK(CK)} + C_{CK(CK\#)})$.
 - $C_{DI_CMD_ADDR} = C_{I(CMD_ADDR)} - 0.5 \times (C_{CK(CK)} + C_{CK(CK\#)})$.

Electrical Specifications – I_{CDD} Parameters

Table 8: DDR3L I_{CDD} Specifications and Conditions (Rev. P)

Notes 1 and 2 apply to the entire table

Combined Symbol	Individual Die Status	Bus Width	-107	Units
I _{CDD0}	I _{CDD0} = 2 × I _{DD0}	x16	58	mA
I _{CDD1}	I _{CDD1} = 2 × I _{DD1}	x16	88	mA
I _{CDD2P0} (slow exit)	I _{CDD2P0} = 2 × I _{DD2P0}	x16	22	mA
I _{CDD2P1} (fast exit)	I _{CDD2P1} = 2 × I _{DD2P1}	x16	22	mA
I _{CDD2Q}	I _{CDD2Q} = 2 × I _{DD2Q}	x16	30	mA
I _{CDD2N}	I _{CDD2N} = 2 × I _{DD2N}	x16	34	mA
I _{CDD2NT}	I _{CDD2NT} = 2 × I _{DD2NT}	x16	44	mA
I _{CDD3P}	I _{CDD3P} = 2 × I _{DD3P}	x16	30	mA
I _{CDD3N}	I _{CDD3N} = 2 × I _{DD3N}	x16	42	mA
I _{CDD4R}	I _{CDD4R} = 2 × I _{DD4R}	x16	180	mA
I _{CDD4W}	I _{CDD4W} = 2 × I _{DD4W}	x16	180	mA
I _{CDD5B}	I _{CDD5B} = 2 × I _{DD5B}	x16	304	mA
I _{CDD6}	I _{CDD6} = 2 × I _{DD6}	x16	30	mA
I _{CDD6ET}	I _{CDD6ET} = 2 × I _{DD6ET}	x16	46	mA
I _{CDD7}	I _{CDD7} = 2 × I _{DD7}	x16	292	mA
I _{CDD8}	I _{CDD8} = 2 × I _{DD8}	x16	26	mA

- Notes:
1. I_{CDD} values reflect the combined current of both individual die. I_{DDx} represents individual die values.
 2. The I_{DD} values must be derated (increased) on IT-option devices when operated outside of the range 0°C ≤ T_C ≤ 85°C:
 - 2a. When T_C < 0°C: I_{DD2P0}, I_{DD2P1} and I_{DD3P} must be derated by 4%; I_{DD4R} and I_{DD4W} must be derated by 2%; and I_{DD6}, I_{DD6ET} and I_{DD7} must be derated by 7%.
 - 2b. When T_C > 85°C: I_{DD4R}, I_{DD4W}, I_{DD5B}, and I_{DD7} must be derated by 5%; I_{DD0}, I_{DD1}, I_{DD2P1}, I_{DD3N}, and I_{DD3P} must be derated by 15%; I_{DD2P0}, I_{DD2Q}, I_{DD2N}, and I_{DD2NT} must be derated by 40%.
 - 2c. When T_C > 95°C: all IDD values must be derated (increased) by 30% from the 85°C specifications.
 - 2d. When T_C > 105°C: all IDDx values must be derated (increased) by 50% from the 85°C specifications.

Revision History

Rev. D – 01/20

- 12/04/2019 Added package code VRP in Options, DDR3L Part Numbers figure, and Thermal Impedance table
- 12/12/2019 Added note 3 VRP material composition: Pb-free SAC Q (92.45% Sn, 4% Ag, 0.5% Cu, 3% Bi, 0.05% Ni) in Package Dimensions
- 12/12/2019 Removed ultra-high (-40 to +125°C) from Thermal Characteristics table

Rev. C – 04/19

- 04/10/2019 Updated DDR3L Input/Output Capacitance table: C_{CK} , C_I , and C_{DI_CTRL}

Rev. B – 02/19

- 01/08/2019 Updated legal status to Production
- 01/08/2019 Updated DDR3L Input/Output Capacitance table in Input/Output Capacitance section

Rev. A – 08/18

- 07/26/2018 Updated thermal characteristics section
- 07/01/2018 Changed Die 0 to Die 1 in Functional Block Diagram
- 04/01/2018 Initial release for DDR3L_8Gb_x16_1_35V_Single_rank_TwinDie

8000 S. Federal Way, P.O. Box 6, Boise, ID 83707-0006, Tel: 208-368-4000

www.micron.com/products/support Sales inquiries: 800-932-4992

Micron and the Micron logo are trademarks of Micron Technology, Inc. TwinDie is a trademark of Micron Technology, Inc.

All other trademarks are the property of their respective owners.

This data sheet contains minimum and maximum limits specified over the power supply and temperature range set forth herein. Although considered final, these specifications are subject to change, as further product development and data characterization sometimes occur.