

Part No.	X = Body Length
PLP5-2-100-D	0.100 ( 2.5mm )
PLP5-2-125-D	0.125 ( 3.2mm )
PLP5-2-2.5MM-D	2.5mm ( 0.100" )
PLP5-2-3MM-D	3mm ( 0.118" )

REV.	DESCRIPTION	DATE	APPROVED
A	Engineering Release	07/15/15	J. C.

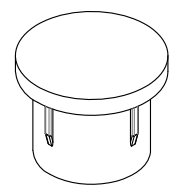
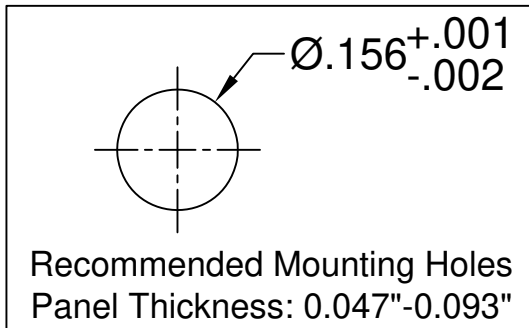
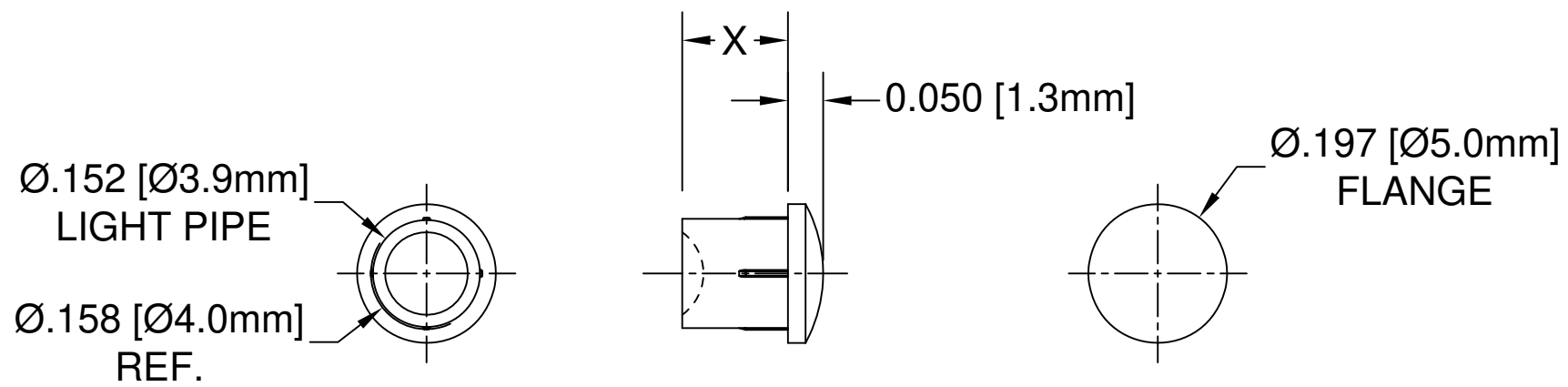

- 2. MATERIAL: POLYCARBONATE, 94V-0, WHITE DIFFUSED.
- 1. GENERAL SPECIFICATIONS: BIVAR MOLDED COMPONENT SPECIFICATION BV00-E101 and BSMC-1001.

STANDARD TOLERANCE ( UNLESS OTHERWISE SPECIFIED )		 4 THOMAS, IRVINE, CA. 92618 TEL: (949) 951-8808 FAX: (949) 951-3974	
DECIMALS	ANGULAR		
.X ± .1	X° ± 1°	 <b>TITLE:</b> PRESS-FIT PANEL MOUNT, 5mm LIGHT PIPE, FRONT MOUNT, DIFFUSED	
.XX ± .01			
.XXX ± .005			
DESIGNED: <b>Brian Oliver</b>	DATE: <b>04/02/15</b>	<b>PART NO:</b> PLP5-2-XXX-D	REVISION: <b>A</b>
CHECKED: <b>A. Wright</b>	DATE: <b>04/02/15</b>	<b>CAGE CODE :</b> 32559	<b>SHEET # 1 OF 1</b>
CAD GENERATED DOCUMENT. DO NOT MEASURE DRAWING.			