

FEATURES

- ±4000 V human body model (HBM) ESD**
- High common-mode input voltage range**
 - 2 V to +65 V operating
 - 3 V to +68 V survival
- Buffered output voltage**
- Wide operating temperature range**
 - 40°C to +125°C for Y grade
 - 40°C to +150°C for H grade
- Excellent ac and dc performance**
 - 10 ppm/°C typical gain drift
 - 120 dB typical CMRR at dc
- Qualified for automotive applications**

APPLICATIONS

- High-side current sensing**
 - Motor controls
 - Transmission controls
 - Diesel injection controls
 - Engine management
 - Suspension controls
 - Vehicle dynamic controls
 - DC to DC converters

GENERAL DESCRIPTION

The **AD8213** is a dual-channel, precision current sense amplifier. It features a set gain of 20 V/V, with a maximum $\pm 0.5\%$ gain error over the entire temperature range. The buffered output voltage directly interfaces with any typical converter. Excellent common-mode rejection from –2 V to +65 V, is independent of the 5 V supply. The **AD8213** performs unidirectional current measurements across a shunt resistor in a variety of industrial and automotive applications, such as motor control, solenoid control, or battery management.

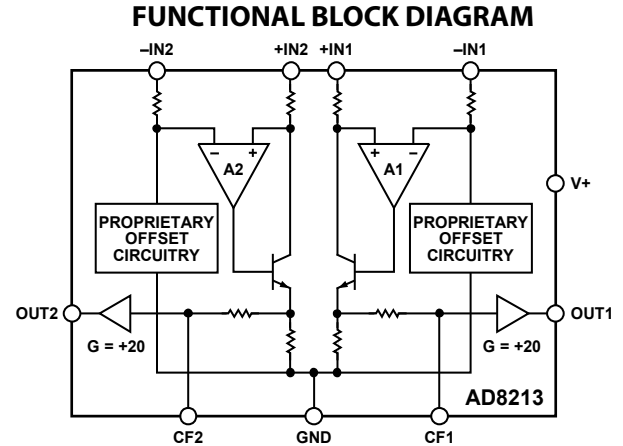

Special circuitry is devoted to output linearity being maintained throughout the input differential voltage range of 0 mV to 250 mV, regardless of the common-mode voltage present. The **AD8213** also features additional pins that allow the user to low-pass filter the input signal before amplifying, via an external capacitor to ground. The **AD8213** has an operating temperature range of –40°C to +125°C for the Y grade, –40°C to +150°C for the H grade and is offered in a small 10-lead MSOP package.

TABLE OF CONTENTS

Features	1	Output Linearity.....	11
Applications.....	1	Low-Pass Filtering.....	11
Functional Block Diagram	1	Applications Information	12
General Description	1	High-Side Current Sense with a Low-Side Switch.....	12
Revision History	2	High-Side Current Sensing	12
Specifications.....	3	Low-Side Current Sensing	12
Absolute Maximum Ratings.....	4	Bidirectional Current Sensing	13
ESD Caution.....	4	Outline Dimensions	14
Pin Configuration and Function Descriptions.....	5	Ordering Guide	14
Typical Performance Characteristics	6	Automotive Products.....	14
Theory of Operation	10		
Application Notes	11		

REVISION HISTORY

12/2016—Rev. C to Rev. D

Changes to Features Section.....	1
Changes to Table 1.....	3
Changes to Figure 30.....	12
Change to Ordering Guide.....	14
Add Automotive Products Section.....	14

10/2013—Rev. B to Rev. C

Changed Offset Voltage (RTI) Parameter from ± 1 mV Maximum to ± 1 mV Typical, Table 1	3
--	---

4/2013—Rev. A to Rev. B

Added H Grade (Throughout)	1
Changes to Table 1.....	3
Added AD8213WH Temperature Range, Table 2.....	4
Updated Outline Dimensions	14
Changes to Ordering Guide	14

5/2009—Rev. 0 to Rev. A

Changes to Ordering Guide	14
---------------------------------	----

5/2007—Revision 0: Initial Version

SPECIFICATIONS

T_{OPR} = operating temperature range, $V_S = 5\text{ V}$, $R_L = 25\text{ k}\Omega$ (R_L is the output load resistor), unless otherwise noted.

Table 1.

Parameter	Test Conditions/Comments	Min	Typ	Max	Unit	
GAIN						
Initial Accuracy	Output voltage (V_O) $\geq 0.1\text{ V dc}$ T_{OPR}		20		V/V	
Accuracy over Temperature			± 0.25		%	
Gain vs. Temperature				± 0.5		%
		0	-10	-25		ppm/ $^{\circ}\text{C}$
VOLTAGE OFFSET						
Offset Voltage (Referred to Input, RTI)	25 $^{\circ}\text{C}$		± 1		mV	
Over Temperature (RTI)	T_{OPR}			± 2.2	mV	
Offset Drift	T_{OPR}			± 12	$\mu\text{V}/^{\circ}\text{C}$	
INPUT						
Input Impedance	Common mode voltage $> 5\text{ V}$ Common mode voltage $< 5\text{ V}$		5		k Ω	
Differential			5		M Ω	
Common Mode				3.5		k Ω
Common-Mode Input Voltage Range		Common-mode continuous	-2		+65	V
Differential Input Voltage Range	Differential input voltage		250		mV	
Common-Mode Rejection	T_{OPR} , $f = \text{dc}$, $V_{CM} > 5\text{ V}$ (see Figure 5)	100	120		dB	
	T_{OPR} , $f = \text{dc}$, $V_{CM} < 5\text{ V}$ (see Figure 5)	80	90		dB	
OUTPUT						
Output Voltage Range Low	AD8213Y, AD8213WY AD8213WH AD8213Y, AD8213WY AD8213WH	0.1	0.05		V	
Output Voltage Range High		0.15		4.95	4.9	V
					4.88	V
Output Impedance			2			Ω
FILTER RESISTOR	C_F access to resistor for low-pass filter	18	20	22	k Ω	
DYNAMIC RESPONSE						
Small Signal -3 dB Bandwidth	$C_{OUT} = 20\text{ pF}$, no filter capacitor (C_F) Output capacitance (C_{OUT}) = 20 pF, $C_F = 20\text{ pF}$		500		kHz	
Slew Rate			4.5		V/ μs	
				2.7		V/ μs
NOISE						
0.1 Hz to 10 Hz, RTI			7		$\mu\text{V p-p}$	
Spectral Density, 1 kHz, RTI			70		nV/ $\sqrt{\text{Hz}}$	
POWER SUPPLY						
Operating Range	$V_{CM} > 5\text{ V}$, per amplifier ¹ , total supply current for two channels AD8213Y, AD8213WY AD8213WH AD8213Y, AD8213WY AD8213WH	4.5		5.5	V	
Quiescent Current Over Temperature			2.5	3.75	4.5	mA
						mA
Power Supply Rejection Ratio			76			dB
		74			dB	
TEMPERATURE RANGE						
For Specified Performance	AD8213Y, AD8213WY AD8213WH	-40		+125	$^{\circ}\text{C}$	
		-40		+150	$^{\circ}\text{C}$	

¹ When the common-mode input is less than 5 V, the supply current increases, which can be calculated by $I_S = -0.52 \times (V_{CM}) + 4.9$ (see Figure 11).

ABSOLUTE MAXIMUM RATINGS

Table 2.

Parameter	Rating
Supply Voltage	12.5 V
Continuous Input Voltage (Survival)	−3 V to +68 V
Reverse Supply Voltage	−0.3 V
ESD Rating	
HBM	±4000 V
Charged Device Model (CDM)	±1000 V
Operating Temperature Range	
AD8213Y, AD8213WY	−40°C to +125°C
AD8213WH	−40°C to +150°C
Storage Temperature Range	−65°C to +150°C
Output Short-Circuit Duration	Indefinite

Stresses at or above those listed under Absolute Maximum Ratings may cause permanent damage to the product. This is a stress rating only; functional operation of the product at these or any other conditions above those indicated in the operational section of this specification is not implied. Operation beyond the maximum operating conditions for extended periods may affect product reliability.

ESD CAUTION



ESD (electrostatic discharge) sensitive device. Charged devices and circuit boards can discharge without detection. Although this product features patented or proprietary protection circuitry, damage may occur on devices subjected to high energy ESD. Therefore, proper ESD precautions should be taken to avoid performance degradation or loss of functionality.

PIN CONFIGURATION AND FUNCTION DESCRIPTIONS

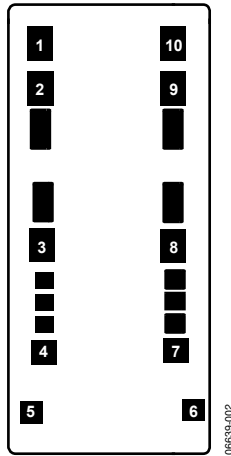

Figure 2. Metallization Diagram

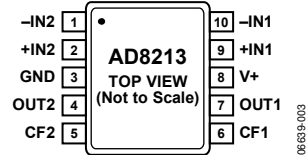

Figure 3. Pin Configuration

Table 3. Pin Function Descriptions

Pin No.	Mnemonic	X	Y	Description
1	-IN2	-401	+677	Inverting Input of the Second Channel.
2	+IN2	-401	+510	Noninverting Input of the Second Channel.
3	GND	-401	-53	Ground.
4	OUT2	-394	-500	Output of the Second Channel.
5	CF2	-448	-768	Low-Pass Filter Pin for the Second Channel.
6	CF1	+448	-768	Low-Pass Filter Pin for the First Channel.
7	OUT1	+394	-500	Output of the First Channel.
8	V+	+401	-61	Supply.
9	+IN1	+401	+510	Noninverting Input of the First Channel.
10	-IN1	+401	+677	Inverting Input of the First Channel.

TYPICAL PERFORMANCE CHARACTERISTICS

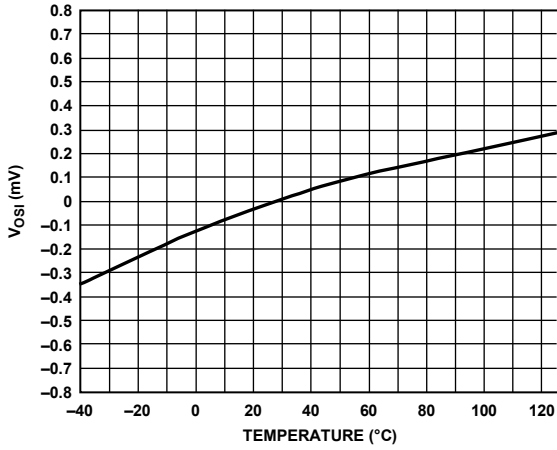

Figure 4. Typical Offset Drift (V_{OS1})

06639-104

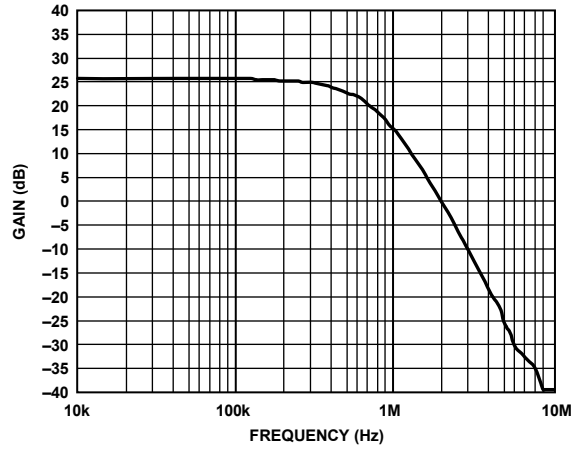

Figure 7. Typical Small Signal Bandwidth, V_{OUT} = 200 mV p-p

06639-008

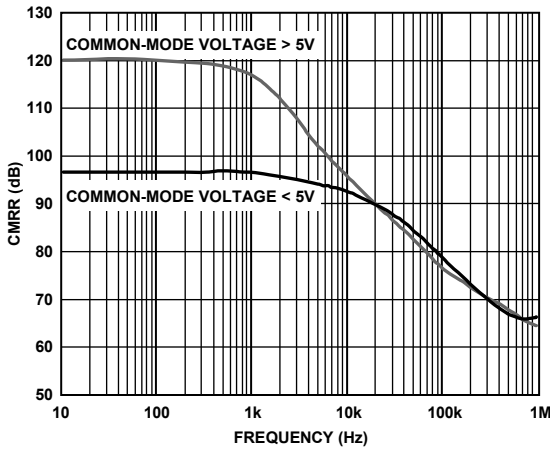

Figure 5. CMRR vs. Frequency

06639-005

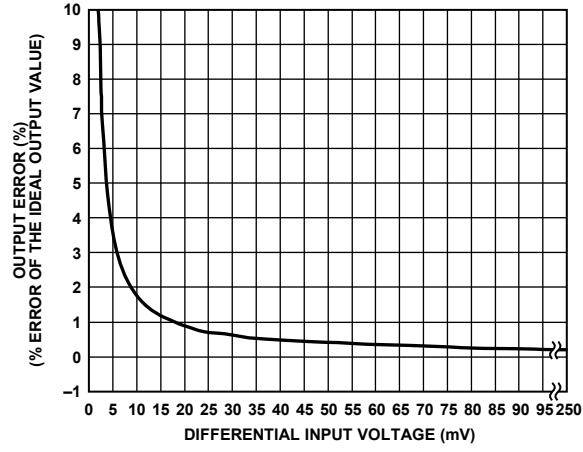

Figure 8. Total Output Error vs. Differential Input Voltage

06639-013

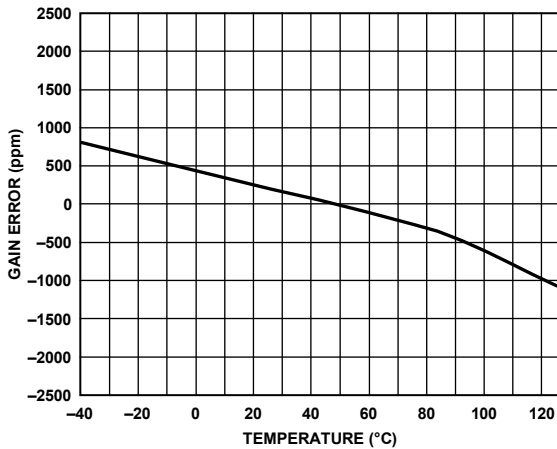

Figure 6. Typical Gain Drift

06639-102

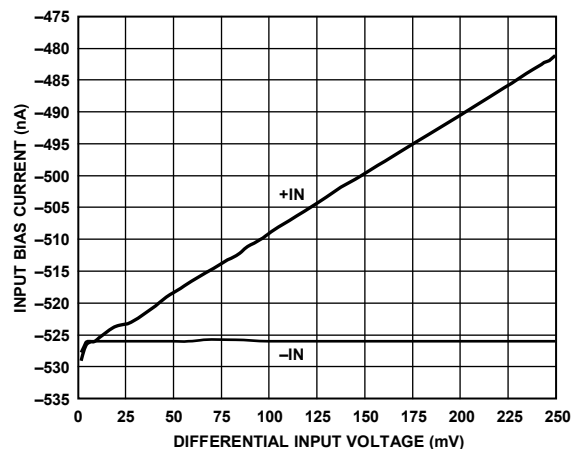

Figure 9. Input Bias Current vs. Differential Input Voltage, V_{CM} = 0 V, Per Channel

06639-010

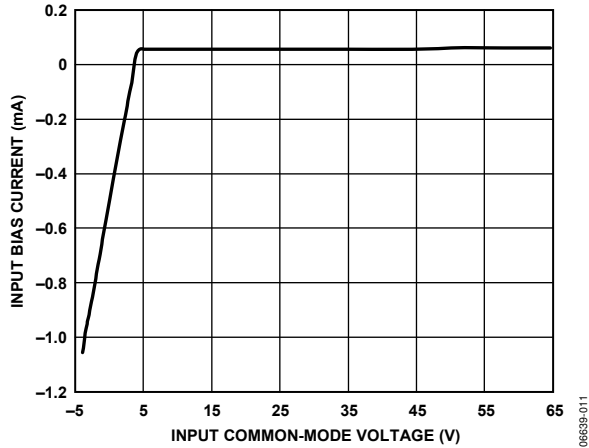

Figure 10. Input Bias Current vs. Input Common-Mode Voltage Per Input

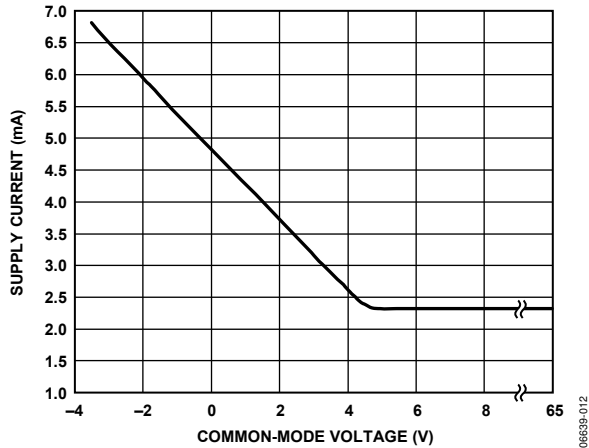

Figure 11. Supply Current vs. Common-Mode Voltage

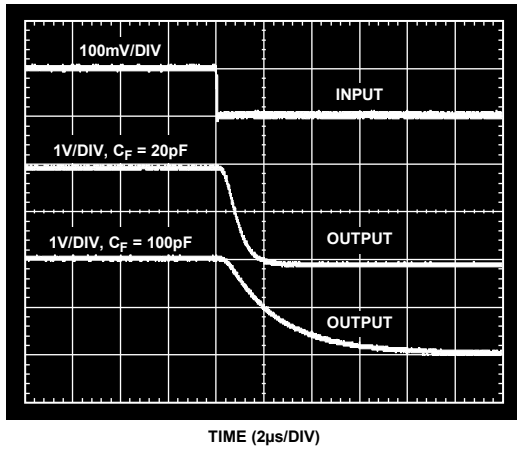

Figure 12. Fall Time

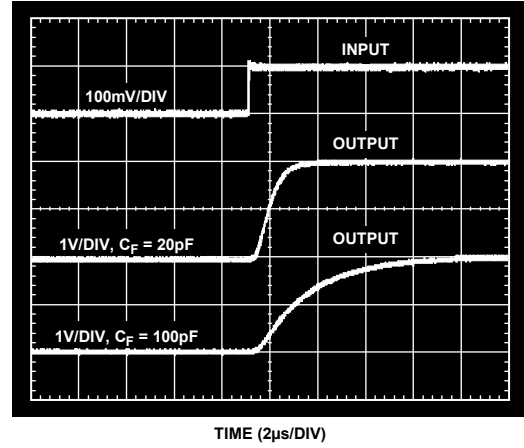

Figure 13. Rise Time

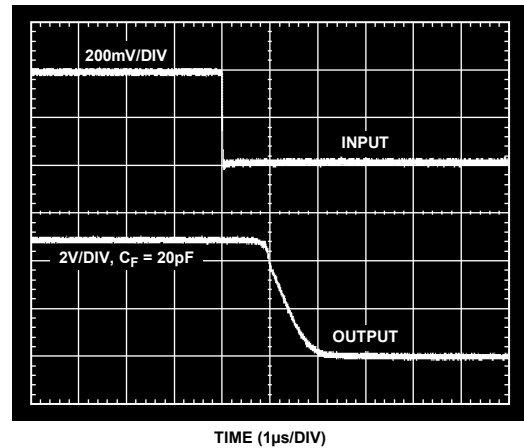

Figure 14. Differential Overload Recovery (Falling)

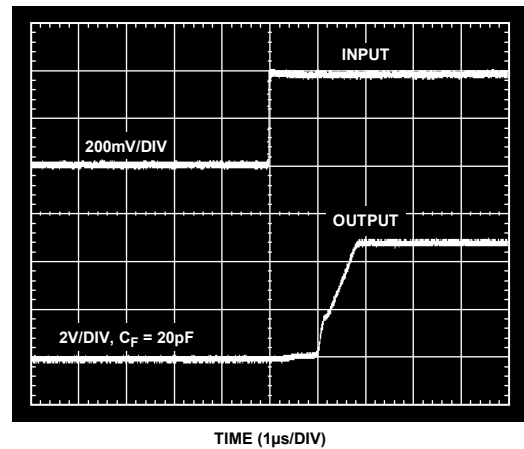

Figure 15. Differential Overload Recovery (Rising)

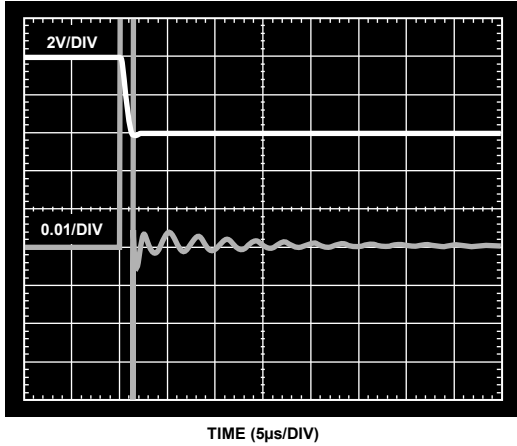

Figure 16. Settling Time (Falling)

06639-105

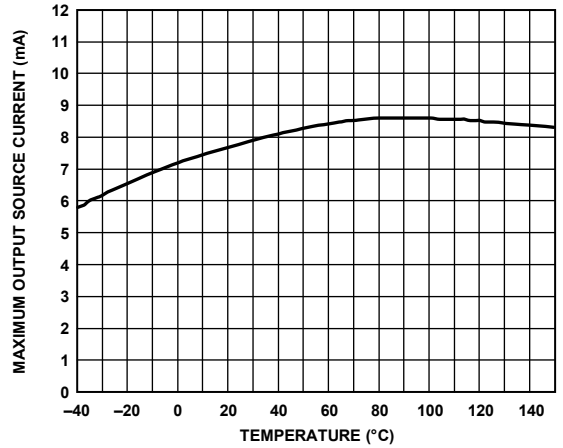

Figure 19. Maximum Output Source Current vs. Temperature Per Channel

06639-021

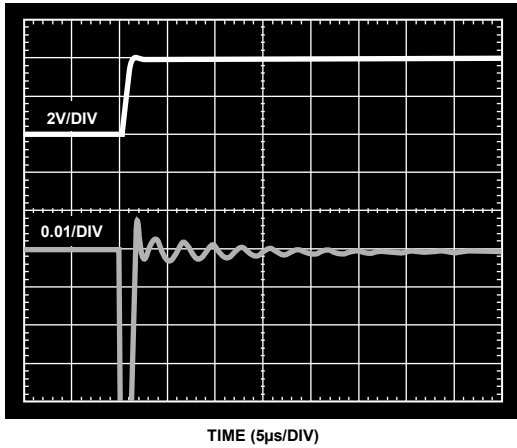

Figure 17. Settling Time (Rising)

06639-106

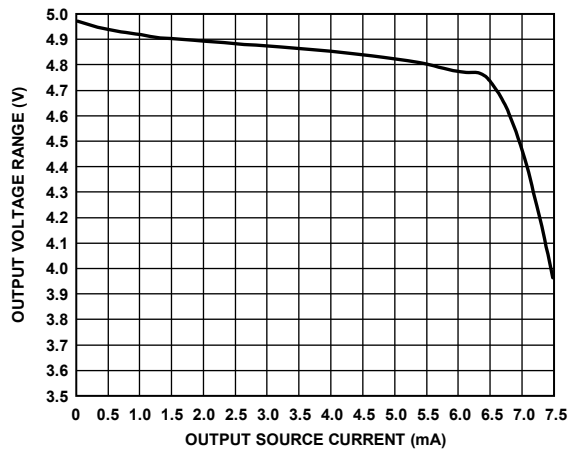

Figure 20. Output Voltage Range vs. Output Source Current Per Channel

06639-023

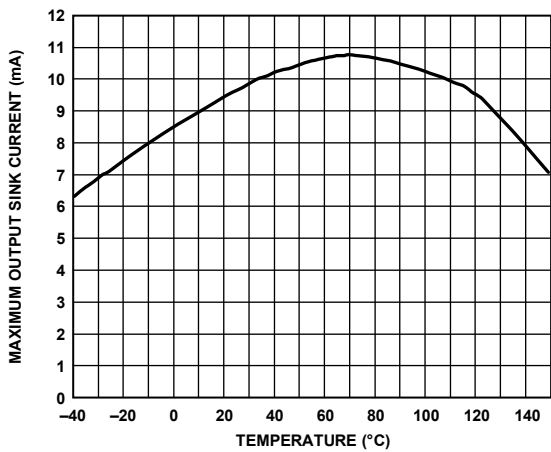

Figure 18. Maximum Output Sink Current vs. Temperature Per Channel

06639-020

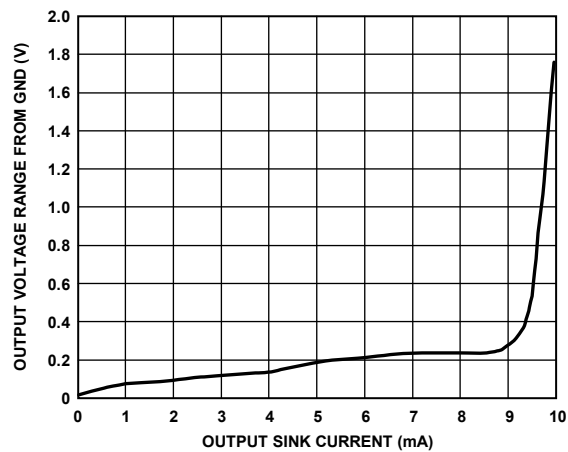

Figure 21. Output Voltage Range from GND vs. Output Sink Current Per Channel

06639-024

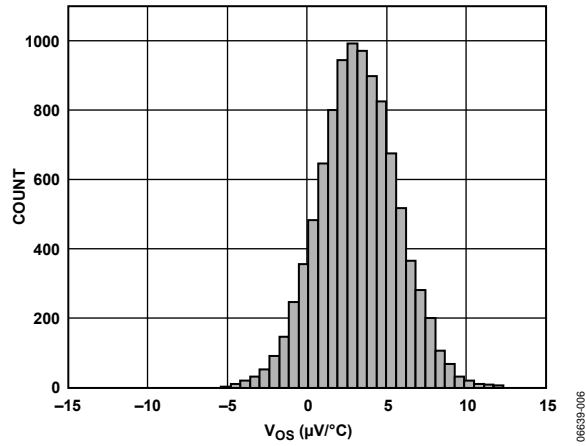

Figure 22. Offset Drift Distribution (V_{OS}), Temperature Range = $-40^{\circ}C$ to $+125^{\circ}C$

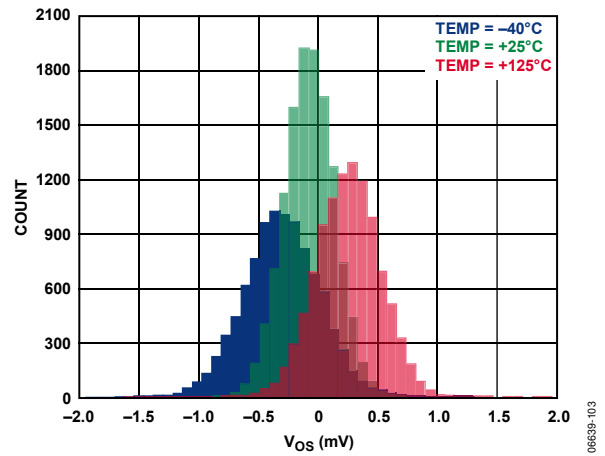

Figure 24. Offset Distribution (V_{OS}), $V_{CM} = 6 V$

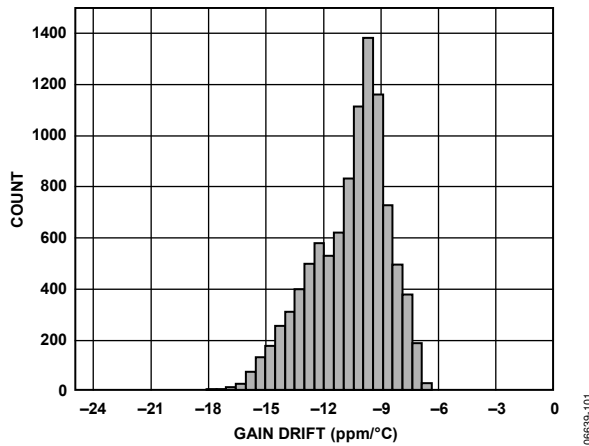

Figure 23. Gain Drift Distribution, Temperature Range = $-40^{\circ}C$ to $+125^{\circ}C$

THEORY OF OPERATION

In typical applications, the AD8213 amplifies a small differential input voltage generated by the load current flowing through a shunt resistor. The AD8213 rejects high common-mode voltages (up to 65 V) and provides a ground referenced, buffered output that interfaces with an analog-to-digital converter (ADC). Figure 25 shows a simplified schematic of the AD8213.

The following explanation refers exclusively to Channel 1 of the AD8213; however, the same explanation applies to Channel 2.

A load current flowing through the external shunt resistor produces a voltage at the input terminals of the AD8213. The input terminals are connected to Amplifier A1 by Resistor R1 (1) and Resistor R1 (2). The inverting terminal, which has very high input impedance is held to $(V_{CM}) - (I_{SHUNT} \times R_{SHUNT})$, because negligible current flows through Resistor R1 (2). Amplifier A1 forces the noninverting input to the same potential. Therefore, the current that flows through Resistor R1 (1), is equal to

$$I_{IN1} = (I_{SHUNT1} \times R_{SHUNT1})/R1_{(1)}$$

This current (I_{IN1}) is converted back to a voltage via R_{OUT1} . The output buffer amplifier has a gain of 20 V/V, and offers excellent accuracy as the internal gain setting resistors are precision trimmed to within 0.01% matching. The resulting output voltage is equal to

$$V_{OUT1} = (I_{SHUNT1} \times R_{SHUNT1}) \times 20$$

Prior to the buffer amplifier, a precision trimmed, 20 kΩ resistor can perform the low-pass filtering of the input signal prior to the amplification stage. By using this resistor, the noise of the input signal does not amplify but is rejected, resulting in a more precise output signal that directly interfaces with a converter. A capacitor from the CF1 pin to GND, results in a low-pass filter with a corner frequency of

$$f_{-3dB} = \frac{1}{2\pi(20000)C_{FILTER}}$$

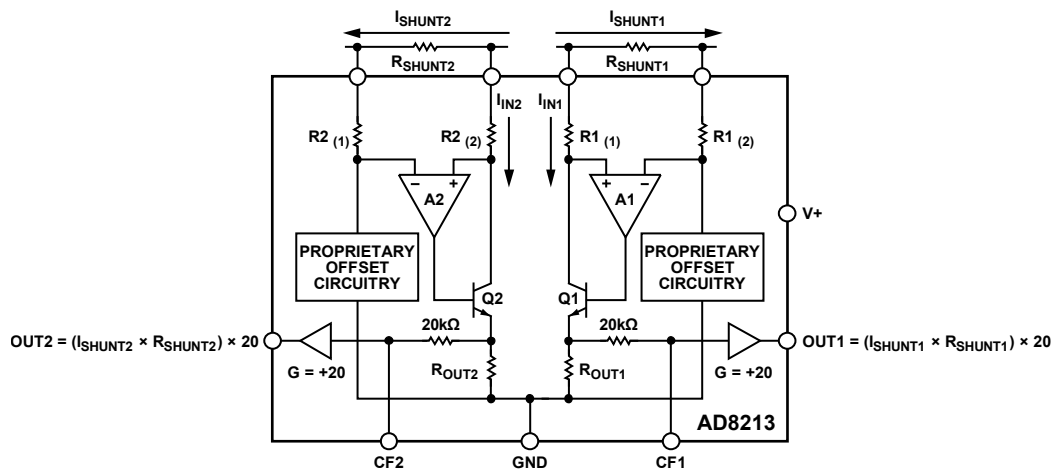

Figure 25. Simplified Schematic

06639-028

APPLICATION NOTES

OUTPUT LINEARITY

In all current sensing applications, and especially in automotive and industrial environments where the common-mode voltage can vary significantly, it is important that the current sensor maintain the specified output linearity, regardless of the input differential or common-mode voltage. The AD8213 contains specific circuitry on the input stage, which ensures that even when the differential input voltage is very small, and the common-mode voltage is also low (below the 5 V supply), the input to output linearity is maintained. Figure 26 displays the input differential voltage vs. the corresponding output voltage at different common modes.

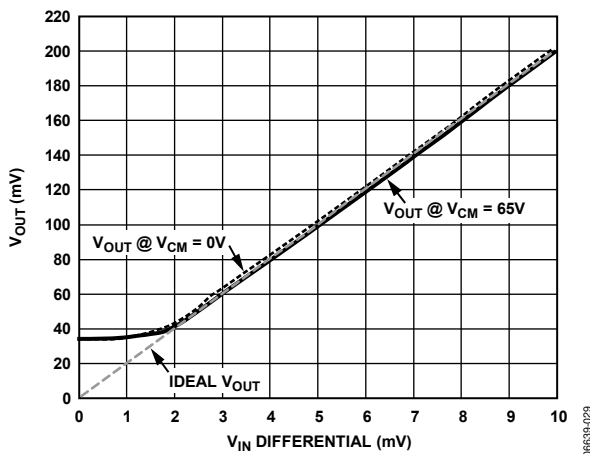

Figure 26. Gain Linearity due to Differential and Common-Mode Voltage

The AD8213 provides a correct output voltage, regardless of the common mode, when the input differential is at least 2 mV, which is due to the voltage range of the output amplifier that can go as low as 33 mV typical. The specified minimum output amplifier voltage is 100 mV in order to provide sufficient guard bands. The ability of the AD8213 to work with very small differential inputs regardless of the common-mode voltage, allows more dynamic range, accuracy, and flexibility in any current sensing application.

LOW-PASS FILTERING

In typical applications, such as motor and solenoid current sensing, filtering the differential input signal of the AD8213 can be beneficial in reducing differential common-mode noise as well as transients and current ripples flowing through the input shunt resistor. Typically, such a filter can be implemented by adding a resistor in series with each input and a capacitor directly between the input pins. However, the AD8213 features a filter pin available after the input stage but before the final amplification stage. The user can connect a capacitor to ground, making a low-pass filter with the internal precision trimmed, 20 kΩ resistor. Connecting this capacitor to ground, results in no gain or CMRR errors. Figure 27 shows the typical connection.

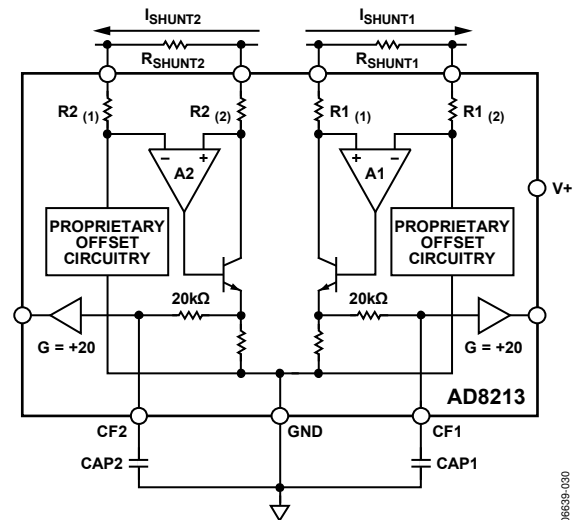

Figure 27. Filter Capacitor Connections

Use the following formula to calculate the 3 dB frequency of this low-pass filter:

$$f_{-3dB} = \frac{1}{2\pi(20000)C_{FILTER}}$$

It is recommended to always place a capacitor from the filter pin to GND to prevent the output chatter due to noise potentially entering through the filter pin and coupling to the output. This capacitor can be a ≈ 20 pF capacitor in cases when all of the bandwidth of the AD8213 is needed in the application.

APPLICATIONS INFORMATION

HIGH-SIDE CURRENT SENSE WITH A LOW-SIDE SWITCH

In such load control configurations, the PWM controlled switch is ground referenced. An inductive load (solenoid) is tied to a power supply. A resistive shunt is placed between the switch and the load (see Figure 28). An advantage of placing the shunt on the high side is that the entire current, including the recirculation current, can be measured because the shunt remains in the loop when the switch is off. In addition, diagnostics can be enhanced because shorts to ground can be detected with the shunt on the high side. In this circuit configuration, when the switch is closed, the common-mode voltage moves down to near the negative rail. When the switch is opened, the voltage reversal across the inductive load causes the common-mode voltage to be held one diode drop above the battery by the clamp diode.

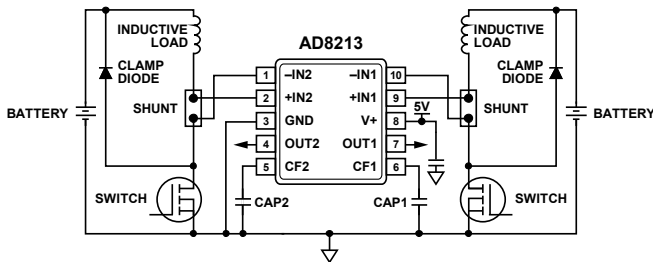

Figure 28. Low-Side Switch

HIGH-SIDE CURRENT SENSING

In this configuration, the shunt resistor is referenced to the battery. High voltage is present at the inputs of the current sense amplifier. In this mode, the recirculation current is measured again and shorts to ground can be detected. When the shunt is battery referenced, the AD8213 produces a linear ground referenced analog output. An AD8214 can also provide an overcurrent detection signal in as little as 100 ns. This feature is useful in high current systems where fast shutdown in overcurrent conditions is essential.

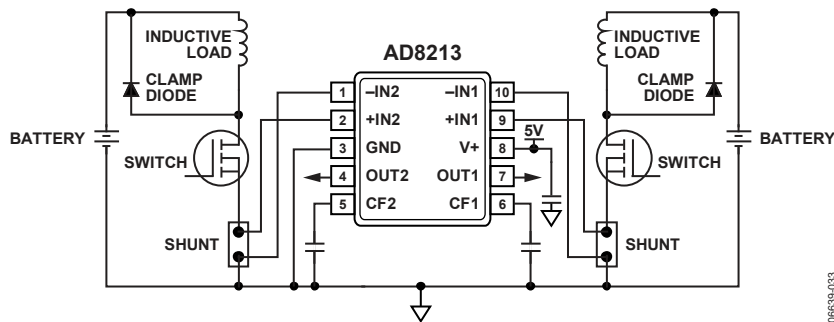

Figure 30. Ground Referenced Shunt Resistor

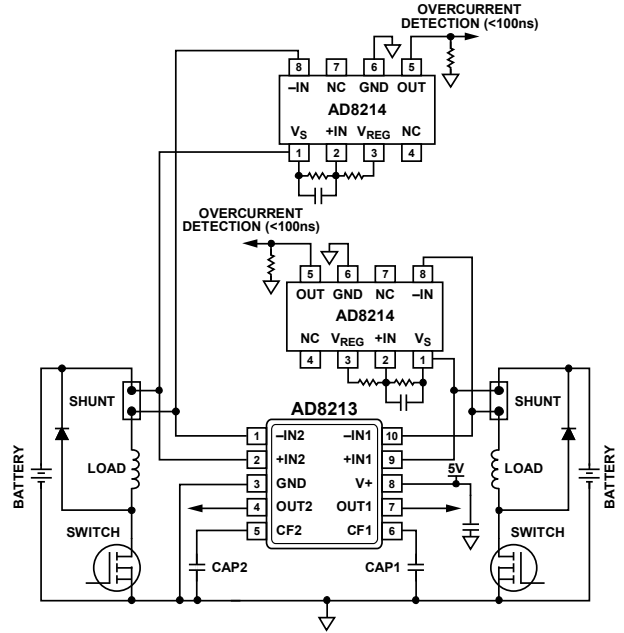

Figure 29. Battery Referenced Shunt Resistor

LOW-SIDE CURRENT SENSING

In systems where low-side current sensing is preferred, the AD8213 provides an integrated solution with great accuracy. Ground noise is rejected, CMRR is typical higher than 90 dB, and output linearity is not compromised, regardless of the input differential voltage.

BIDIRECTIONAL CURRENT SENSING

The AD8213 can also be configured to sense current in both directions at the inputs. This configuration is useful in charge/discharge applications. A typical connection diagram is shown in Figure 31. In this mode, Channel 1 monitors I_{LOAD} , and Channel 2 monitors I_{CHARGE} .

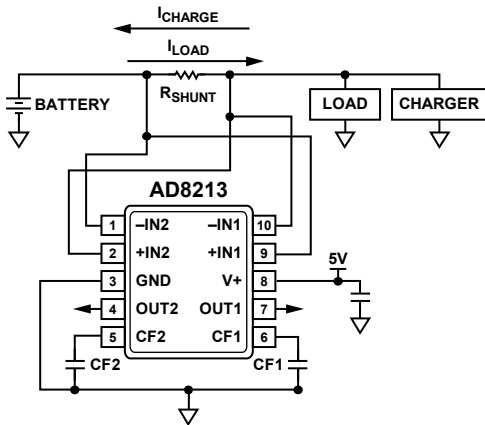

Figure 31. Bidirectional Current Sensing

For applications requiring a bidirectional current measurement, an optimal solution can be using a single channel device, which offers the same functionality as the previous circuit. The AD8210 is a single channel current sensor featuring bidirectional capability. The typical connection diagram for the AD8210 in bidirectional applications is shown in Figure 32.

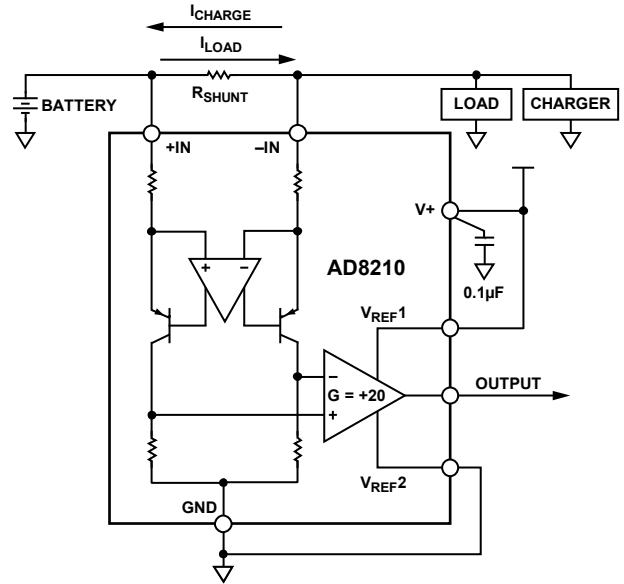
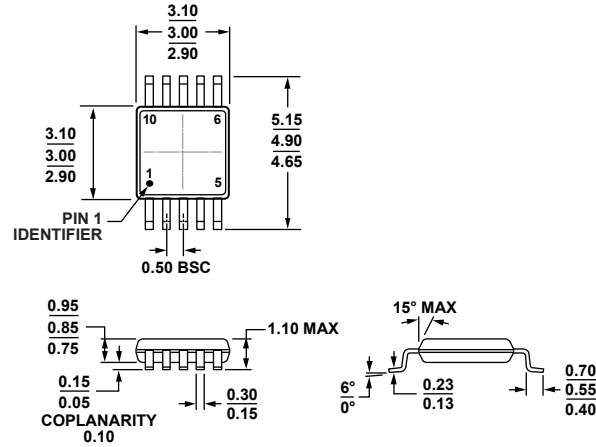

Figure 32. AD8210 in Bidirectional Applications

OUTLINE DIMENSIONS



COMPLIANT TO JEDEC STANDARDS MO-187-BA

Figure 33. 10-Lead Mini Small Outline Package [MSOP]
(RM-10)

Dimensions shown in millimeters

091709-A

ORDERING GUIDE

Model ^{1,2}	Temperature Range	Package Description	Package Option	Branding
AD8213YRMZ	-40°C to +125°C	10-Lead Mini Small Outline Package [MSOP]	RM-10	H0U
AD8213YRMZ-RL	-40°C to +125°C	10-Lead Mini Small Outline Package [MSOP], 13" Tape and Reel	RM-10	H0U
AD8213YRMZ-R7	-40°C to +125°C	10-Lead Mini Small Outline Package [MSOP], 7" Tape and Reel	RM-10	H0U
AD8213WYRMZ	-40°C to +125°C	10-Lead Mini Small Outline Package [MSOP]	RM-10	Y2B
AD8213WYRMZ-RL	-40°C to +125°C	10-Lead Mini Small Outline Package [MSOP], 13" Tape and Reel	RM-10	Y2B
AD8213WYRMZ-R7	-40°C to +125°C	10-Lead Mini Small Outline Package [MSOP], 7" Tape and Reel	RM-10	Y2B
AD8213WHRMZ	-40°C to +150°C	10-Lead Mini Small Outline Package [MSOP]	RM-10	Y5C
AD8213WHRMZ-RL	-40°C to +150°C	10-Lead Mini Small Outline Package [MSOP], 13" Tape and Reel	RM-10	Y5C
AD8213WHRMZ-R7	-40°C to +150°C	10-Lead Mini Small Outline Package [MSOP], 7" Tape and Reel	RM-10	Y5C

¹ Z = RoHS Compliant Part.

² W = Qualified for Automotive Applications.

AUTOMOTIVE PRODUCTS

The [AD8213W](#) models are available with controlled manufacturing to support the quality and reliability requirements of automotive applications. Note that these automotive models may have specifications that differ from the commercial models; therefore, designers should review the Specifications section of this data sheet carefully. Only the automotive grade products shown are available for use in automotive applications. Contact your local Analog Devices account representative for specific product ordering information and to obtain the specific Automotive Reliability reports for these models.