

# NU-C1 SERIES

1W UNREGULATED

# DANUBE

## FEATURES

- UP TO 1W UNREGULATED OUTPUT POWER
- 100% BURN IN
- HIGH EFFICIENCY
- SMD TECHNOLOGY
- LOW COST
- UL 94V-0 PACKAGE MATERIAL
- CUSTOM SOLUTIONS AVAILABLE
- MTBF>880,000 HOURS
- RoHS COMPLIANT
- 3 YEARS WARRANTY



## OUTPUT SPECIFICATIONS

Voltage Set-point Accuracy	+/-2% max.
Temperature Coefficient	+/-0.03%/°C
Ripple & Noise(20MHz BW) <sup>1</sup>	100mVp-p max.
Line Regulation <sup>2</sup>	+/-1.2% max.
Load Regulation <sup>3</sup>	+/-8% max.
Minimum Load	10% of Full Load
Short Circuit Protection	Momentary
S-Suffix	Continuous

## INPUT SPECIFICATIONS

Input Voltage Range	+/-10% max.
Input Filter	Capacitor Type
Protection	Fuse Recommended

## GENERAL SPECIFICATIONS

Efficiency	70%-82%
Isolation Voltage <sup>4</sup>	1500 VDC min.
Isolation Resistance	10 <sup>9</sup> ohms min.
Isolation Capacitance	80pF max.
Switching Frequency	100KHz typ.
MTBF <sup>5</sup>	>880,000 Hours
Weight	1.1g typ.
Case Material	Non-Conductive Plastic
Case Size	12.9mm*10.9mm*7.1mm
Radiated Emissions	EN55032 Class B

## ENVIRONMENTAL SPECIFICATIONS

Operating Temperature	-40 °C to +85 °C
s-suffix	-40 °C to +100 °C
Storage Temperature	-55 °C to +125 °C
Humidity	95% max.
Cooling	Free-Air Convection

ALL SPECIFICATIONS TYPICAL AT NOMINAL LINE, FULL LOAD, AND 25 °C UNLESS OTHERWISE NOTED.

<sup>1</sup> Measured with 1uF ceramic capacitor connect to the output pins.

<sup>2</sup> Line Regulation is for a 1.0% change in input Voltage.

<sup>3</sup> Load Regulation is for output load current change from 20% to 100%.

<sup>4</sup> For 10 seconds.

<sup>5</sup> MIL-HDBK-217F@25 °C, Ground Benign.

● **SELECTION GUIDE**  
**1W 1500VDC ISOLATION**

MODEL NUMBER	INPUT VOLTAGE (VDC)	OUTPUT VOLTAGE (VDC)	OUTPUT CURRENT (mA)	INPUT <sup>6</sup>		EFF (%) <sup>7</sup>	ISOLATION (VDC)	PACKAGE
				CURRENT(mA)				
				FULL LOAD	NO LOAD			
NUS-03.303.3C1	3.3	3.3	300	406	40	74	1500	C
NUS-0503.3C1(S)	5	3.3	300	267	35	75	1500	C
NUS-0505C1(S)	5	5	200	260	35	77	1500	C
NUS-0512C1(S)	5	12	84	257	25	78	1500	C
NUS-0515C1(S)	5	15	67	253	28	79	1500	C
NUS-1203.3C1(S)	12	3.3	300	111	14	75	1500	C
NUS-1205C1(S)	12	5	200	107	14	78	1500	C
NUS-1212C1(S)	12	12	84	103	10	81	1500	C
NUS-1215C1(S)	12	15	67	102	12	82	1500	C
NUS-2405C1(S)	24	5	200	54	11	76	1500	C
NUS-2412C1(S)	24	12	84	54	11	76	1500	C
NUS-2415C1(S)	24	15	67	54	11	76	1500	C

*Note: Other input to output voltages may be available. Please contact factory.*

<sup>6</sup> NOMINAL INPUT VOLTAGE.

<sup>7</sup> NOMINAL INPUT VOLTAGE, FULL LOAD.

## MECHANICAL DIMENSIONS & RECOMMENDED FOOTPRINT DETAILS

### PACKAGE "C"

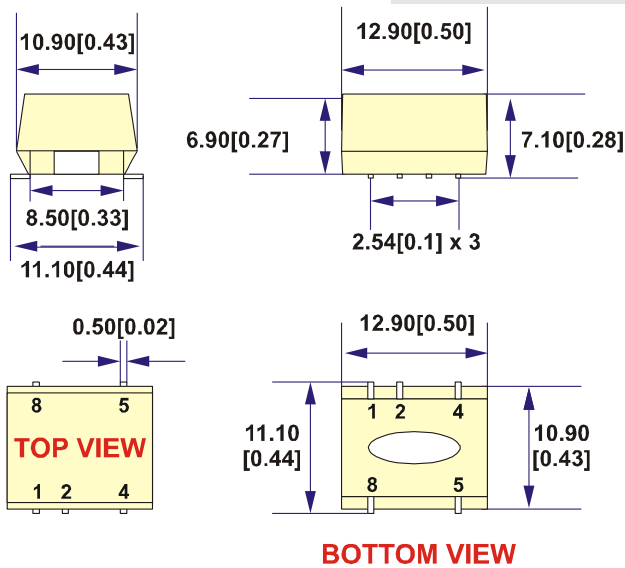

PIN	SINGLE
1	-Vin
2	+Vin
4	-Vout
5	+Vout
8	NC

NOTE : All Dimensions are in mm [inches]

1. Pin Size is 0.50x0.30mm[0.02x0.01"]

2. Pin is Tolerance .XX= ±0.07mm

3. Tolerance .X or .XX= ±0.5mm

All dimensions are in mm[inches]

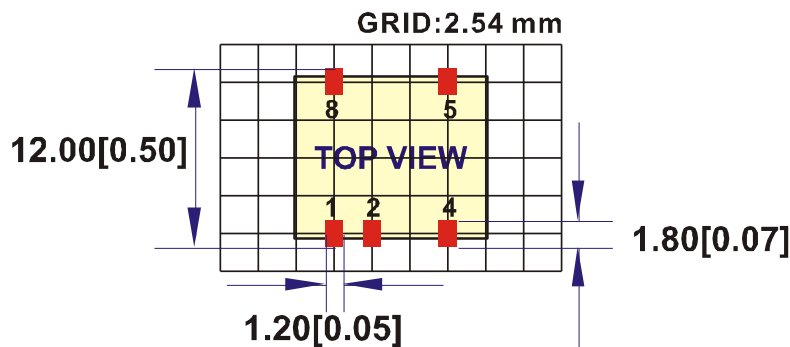

## REFLOW SOLDERING CURVE

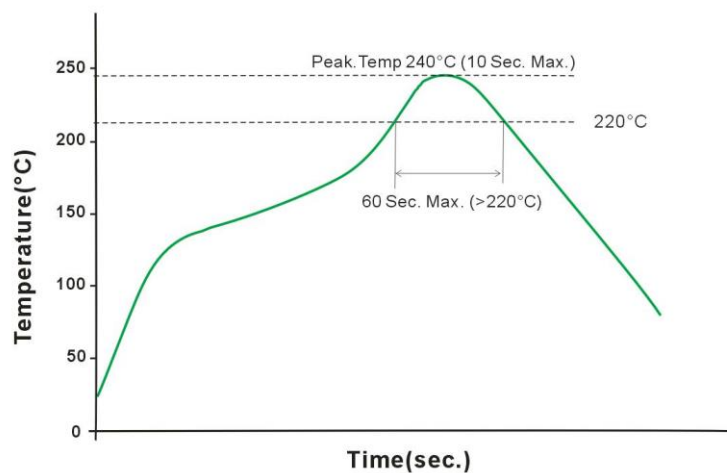

Remark: The curve applies only to the hot air reflow soldering.

## ● SIMPLIFIED SCHEMATIC

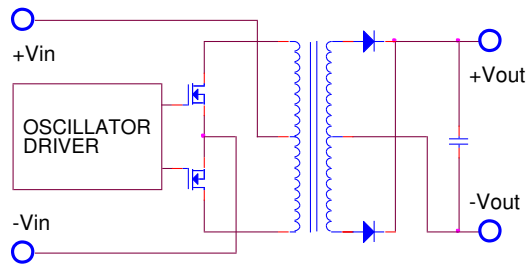

## ● TYPICAL APPLICATIONS

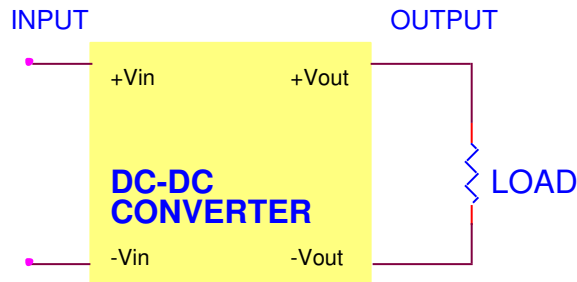

## ● TYPICAL PERFORMANCE CURVES

Specifications typical at  $t_a=25^\circ\text{C}$ , nominal input voltage, rated output current unless otherwise specified.

### OUTPUT LOAD VS EFFICIENCY

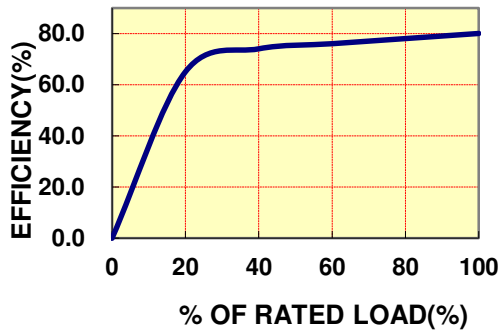

### TEMPERATURE DERATING

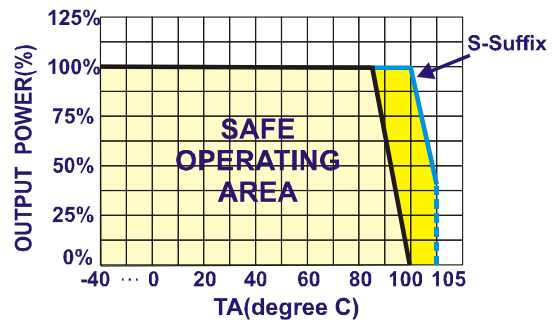

## ● INPUT FUSE SELECTION GUIDE 1W 1500VDC ISOLATION

4.5-5.5V INPUT VOLTAGE(VDC)	10.8-13.2V INPUT VOLTAGE(VDC)	21.6-26.4V INPUT VOLTAGE(VDC)
750mA Slow-Blow Type	300mA Slow-Blow Type	150mA Slow-Blow Type

**Note:** Certain applications may require the installation of external fuse in front of the input.

### **NU-C1 SERIES APPLICATION NOTES:**

#### **EXTERNAL CAPACITANCE REQUIREMENTS:**

Output filtering is required for operation. A minimum of 10uF is needed. Output capacitance may be increased for additional filtering, not to exceed 220uF.

To meet the reflected ripple requirements of the converter, an input impedance of less than 0.5 ohm from DC to 250KHz is required.

We Can Offer EMC-Filter According To EN55032 Class B.

#### **Negative Outputs:**

A negative output voltage may be obtained by connecting the +OUT to circuit ground and connecting -OUT as the negative output.

---



---

### **FOR MORE INFORMATION CALL:**

**Danube Enterprise Co., Ltd.**

**Tel: 886-7-3755165**

**Fax: 886-7-3755330**

**E-mail: danube@ms10.hinet.net**

**Home Page**

**<http://www.danube.com.tw>**

---



---