

REVISIONS				
P	LTR	DESCRIPTION	DATE	APVD
	J4	REVISED PER ECN-22-150900	27APR2022	RK CSD

AMP WIRE RANGE	E13288 Listed
1/0 AWG SOLID OR STRANDED	1/0 AWG STRANDED

LR7189 Certified
1/0 AWG SOLID OR STRANDED

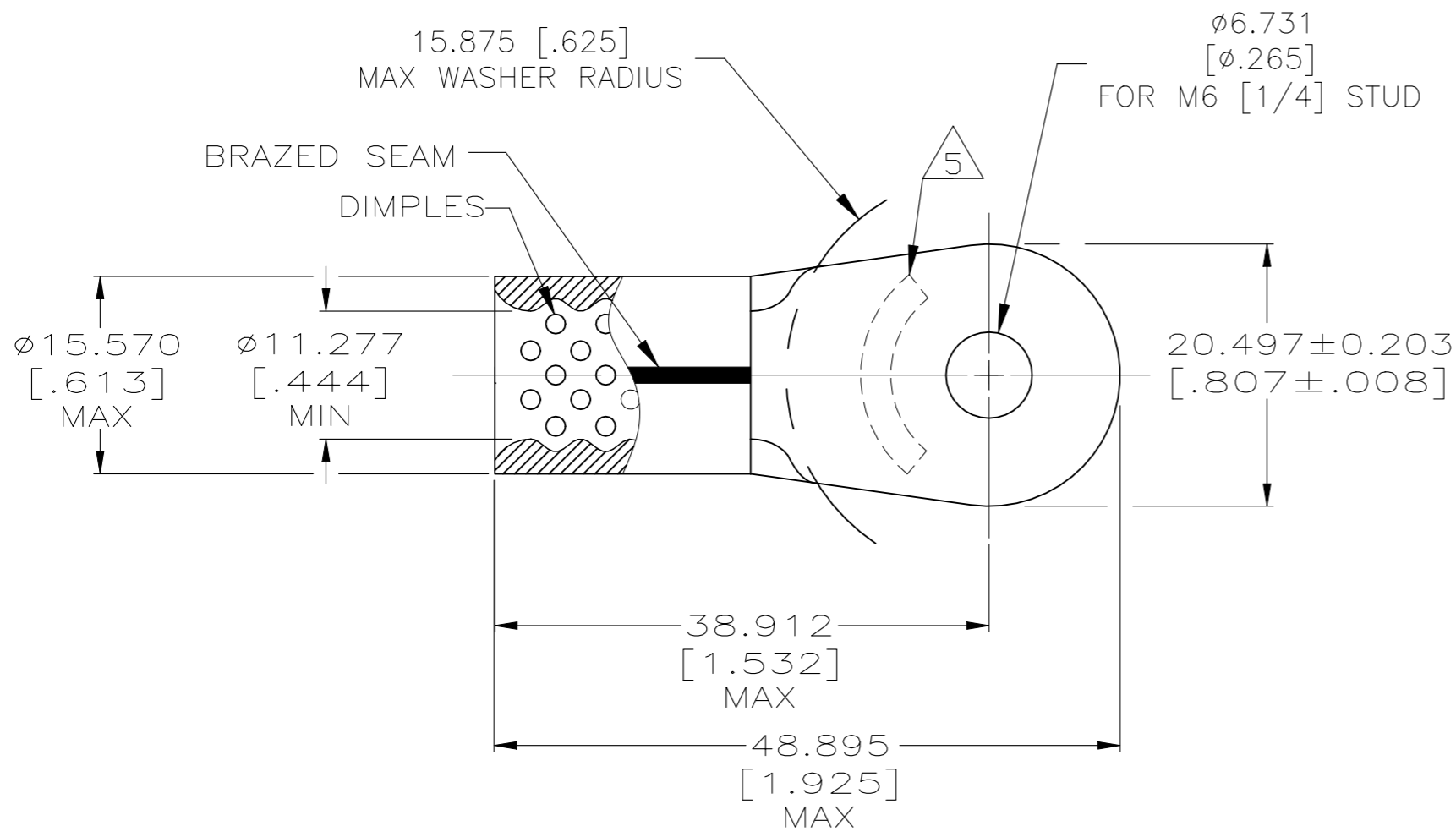

- 1 TIN PLATE 0.00254[.000100] MIN EXT THK PER ASTM B545
- 2 NOTE DELETED
- 3 MATERIAL THICKNESS 1.778±0.076 [.070±.003]
- 4 NICKEL PLATE 0.00762[.000300] MIN EXT THK PER SAE AMS QQ-N-290
- 5 STAMP 1/0 W* APPROX AS SHOWN
- 6 MATERIAL: COPPER PER ASTM B152, ANNEALED
- 7 NOT UL, CSA OR MILITARY APPROVED. FOR STRANDED WIRE ONLY
- 8 PRODUCT SPECIFICATION UL 486A-B

9 PRODUCT SPECIFICATION 108-32046
APPLICATION SPECIFICATION 114-2162

9 4 7	343°C [649°F]	50	LOOSE PIECE	321866-1
8	170°C [338°F]	50	LOOSE PIECE	321866
	MAX RECOMMENDED TEMP	QTY	PACKAGE TYPE	PART NO.

MAX RECOMMENDED OPERATING TEMPERATURE: SEE TABLE	THIS DRAWING IS A CONTROLLED DOCUMENT.		DWN DK SCHRUM 8/30/91	TE Connectivity		
	VOLTAGE RATING: N/A	DIMENSIONS: mm[INCHES]	TOLERANCES UNLESS OTHERWISE SPECIFIED:			
CIRCULAR MIL AREA: 42.4-60.6mm² [83,700-118,500]	MATERIAL 6	FINISH 1 - 4	APVD AJ KAUFMAN 9/30/91	NAME TERMINAL, RING TONGUE, SOLISTRAND AND STRATO-THERM HR, WIRE SIZE 1/0 AWG		
			PRODUCT SPEC 9 8	SIZE A3	CAGE CODE 00779	DRAWING NO C-321866
			APPLICATION SPEC 9	RESTRICTED TO		
			WEIGHT -	CUSTOMER DRAWING	SCALE 2:1	SHEET 1 OF 1
					REV J4	