

Miniature transceiver STKNX evaluation and development kit

Data brief

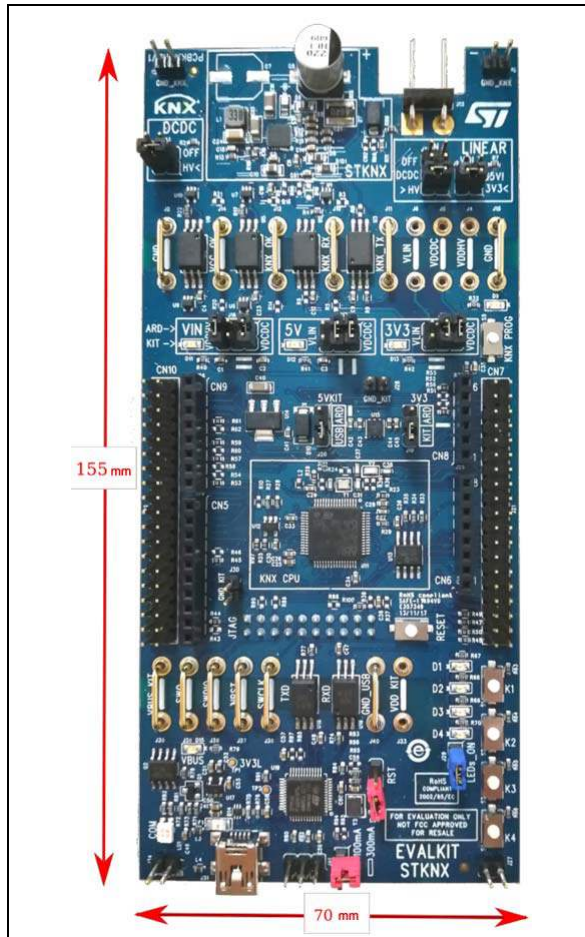

Features

- Full KNX twisted pair device development kit based on the STKNX miniature transceiver
- Controlled by STM32F103 microcontroller 32-bit Cortex[®]-M3 - 16 MHz - 128 kB Flash
- Twisted pair TP1-256 support
- Compatible with ETS engineering tool software
- Test firmware already downloaded in the board to demonstrate features
- Includes originally TAPKO KNX protocol stack KA1stack
- Supported development environments: AC6 OpenSTM32 (Linux[®], Windows[®] and Mac OS-X) or Atollic TrueSTUDIO[®] (Linux and Windows)
- JTAG debug through isolated USB host interface (ST-LINK/V2-1 on-board)
- Standard serial wire debug (SWD) and JTAG interfaces available on standard HE10 20-pin connector
- Connectors for extension board compatible with Arduino[™] and ST Morpho standards
- UART through isolated USB host interface for connecting a PC
- No external supply needed during SW development in “desktop mode” (KNX disconnected), USB supply only
- Power supply flexibility exploiting whole supplies options offered by STKNX
- 1 button and 1 LED for KNX programming
- 4 buttons and 4 LEDs for basic KNX sensors and actuators emulation
- Optional 32.768 kHz crystal for RTC mode
- Optional CPU reset control from STKNX
- STKNX area routed on 2 PCB layers only, for reference layout
- Compliant with bus family standard EN 50491
- Complete reference design suitable to implement products compatibles with KNX standards:
 - CENELEC EN 50090 (EU HBES)
 - CEN EN 13321-1/2 (EU BA)
 - ISO/IEC 14543-3 (World HES)
 - GB/T 20965 (Chinese HBC)
 - ANSI/ASHRAE Standard 135 (USA)
- Includes optional isolation mode for developing SELV product according to EN 61140
- Operating temperature range -40 °C to +85 °C

1 Description

The EVALKITSTKNX kit is a board integrating the STMicroelectronics miniature STKNX transceiver. This kit includes all the necessary components both to evaluate the performances of the STKNX circuit and to develop a KNX device on twisted pair medium according to the TP1-256 standard.

The system is controlled by an STM32F103RBT6 microcontroller hosting originally the KAlstack KNX protocol stack developed by TAPKO Technologies GmbH company.

By using the Arduino and Morpho extension connectors, the kit allows the user to connect existing STM32 expansion boards or to develop a custom board to realize the complete prototype of a KNX device.

An LED dimming application example for the EVALKITSTKNX has been developed, using the X-NUCLEO-LED16A1 expansion board and the software package for the AC6 OpenSTM32 development environment available on st.com. This example is based on a limited version of the TAPKO KNX protocol stack.

The ST-LINK/V2-1 debugger/programmer embedded on-board offers the user all the necessary features to debug and program the software environment without the need of a separated probe, but just by means of a USB connection. An HE10 20-pin connector is however also provided to use any alternative debug environment through serial wire debug (SWD) and JTAG interfaces.

The USB connection also offers a mass-storage profile for ST-LINK development and an isolated connection with the UART of the target STM32.

Jumpers allow the power supplies to be configured in several modes. Supply from the KNX only (STKNX feature) and partially or totally from the extension board. When no STKNX bus activity is necessary, the kit can be autonomously supplied by the user PC through the USB connector, thus allowing comfortable debug/development/integration of the embedded software on a desktop without the need of the KNX power supply.

The standard KNX programming button and LED are present on the kit. In addition, 4 basic buttons and 4 LEDs are available to emulate basic KNX sensors/actuators or to propose any debug facility.

The evaluation kit provides isolators between the microcontroller and the STKNX. Disabled by default, they can be enabled to allow development in any condition of an SELV product in accordance to the EN 61140.

The kit is compliant with the bus family standard EN 50491 and is suitable for designing products compatible with KNX standards CENELEC EN 50090 (EU HBES), CEN EN 13321-1/2 (EU BA), ISO/IEC 14543-3 (World HES), GB/T 20965 (Chinese HBC) and ANSI/ASHRAE standard 135 (USA).

2 Block diagram

Figure 1. EVALKITSTKNX functional block diagram

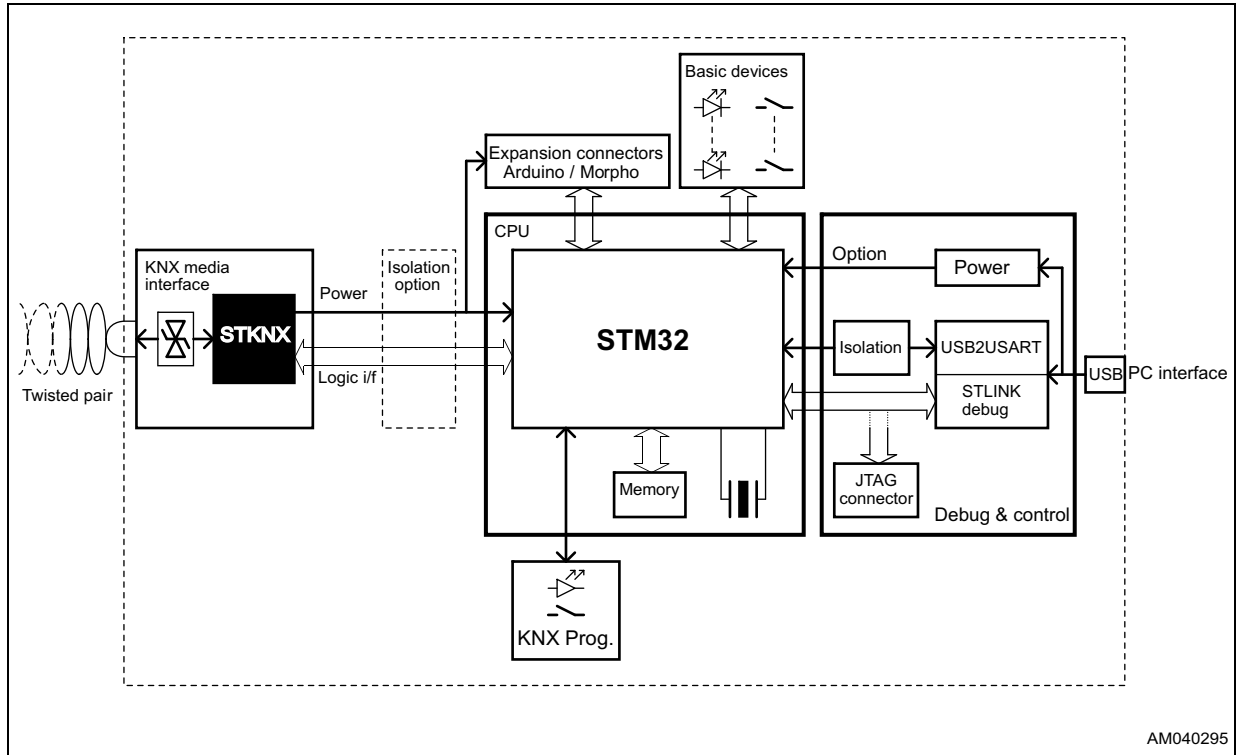

3 Revision history

Table 1. Document revision history

Date	Revision	Changes
14-Feb-2018	1	Initial release.

IMPORTANT NOTICE – PLEASE READ CAREFULLY

STMicroelectronics NV and its subsidiaries ("ST") reserve the right to make changes, corrections, enhancements, modifications, and improvements to ST products and/or to this document at any time without notice. Purchasers should obtain the latest relevant information on ST products before placing orders. ST products are sold pursuant to ST's terms and conditions of sale in place at the time of order acknowledgement.

Purchasers are solely responsible for the choice, selection, and use of ST products and ST assumes no liability for application assistance or the design of Purchasers' products.

No license, express or implied, to any intellectual property right is granted by ST herein.

Resale of ST products with provisions different from the information set forth herein shall void any warranty granted by ST for such product.

ST and the ST logo are trademarks of ST. All other product or service names are the property of their respective owners.

Information in this document supersedes and replaces information previously supplied in any prior versions of this document.

© 2018 STMicroelectronics – All rights reserved