

LOC		DIST		REVISIONS			
GP	00	P	LTN	DESCRIPTION	DATE	DWN	APVD
		A		RELEASED PER ECO-12-013192	16OCT2012	BMM	MRS
		B		REVISED PER ECO-13-003777	19MAR2013	CJV	MRS

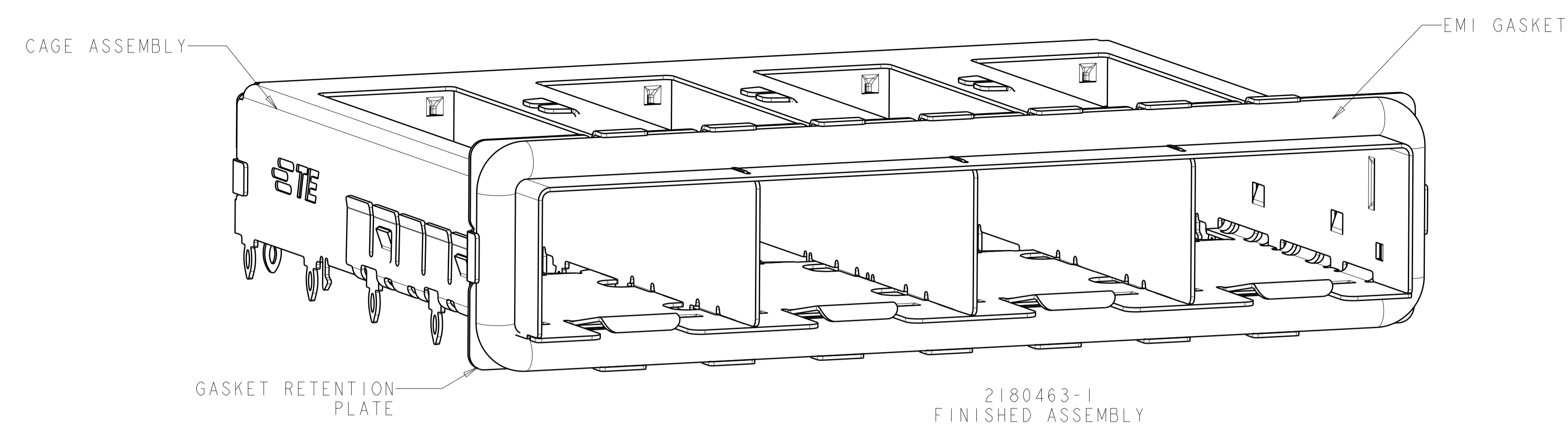

- 1 MATERIAL:  
 CAGE ASSEMBLY: NICKEL SILVER ALLOY  
 GASKET RETENTION PLATE: STAINLESS STEEL  
 EMI GASKET: PLATED FILLED SILICONE
- 2 MINIMUM PC BOARD THICKNESS:  
 SINGLE SIDED = 1.50mm
- 3 PADS AND VIAS CHASSIS GROUND.
- 4 DATUM AND BASIC DIMENSION ESTABLISHED BY CUSTOMER.
- 5 MATES WITH SFP MSA COMPLIANT TRANSCEIVERS.
- 6 INTERPRETATION OF DATUM REFERENCE FRAME IN ACCORDANCE WITH SECT 4.4.1.1 OF ASME Y14.5M-1994.
- 7 REFERENCE APPLICATION SPEC. 114-13120, HOLE A, FOR RECOMMENDED DRILL HOLE DIAMETER AND PLATING THICKNESS.
- 8 REFERENCE APPLICATION SPEC. 114-13120, HOLE B, FOR RECOMMENDED DRILL HOLE DIAMETER AND PLATING THICKNESS.
- 9 HOLE PATTERN REPEATS FOR EACH PORT. SPACING BETWEEN PORTS IS 14.25mm.

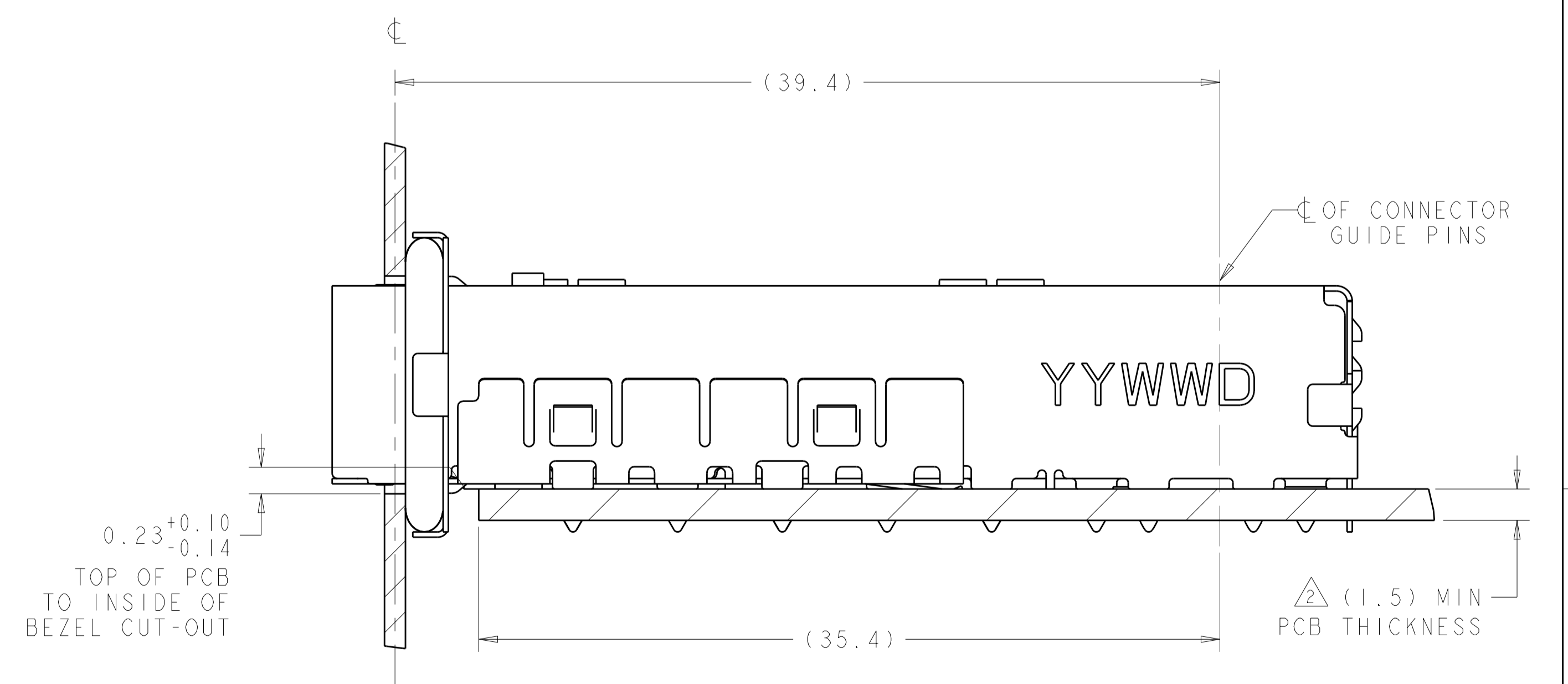
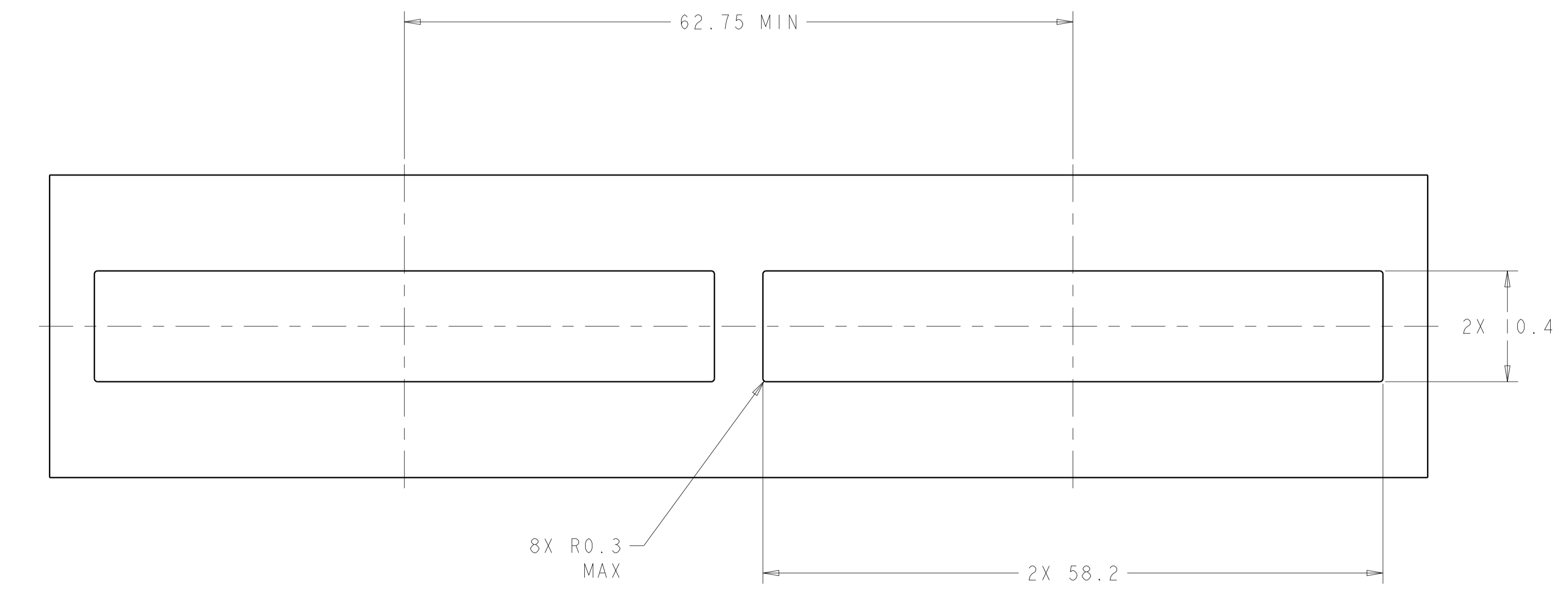
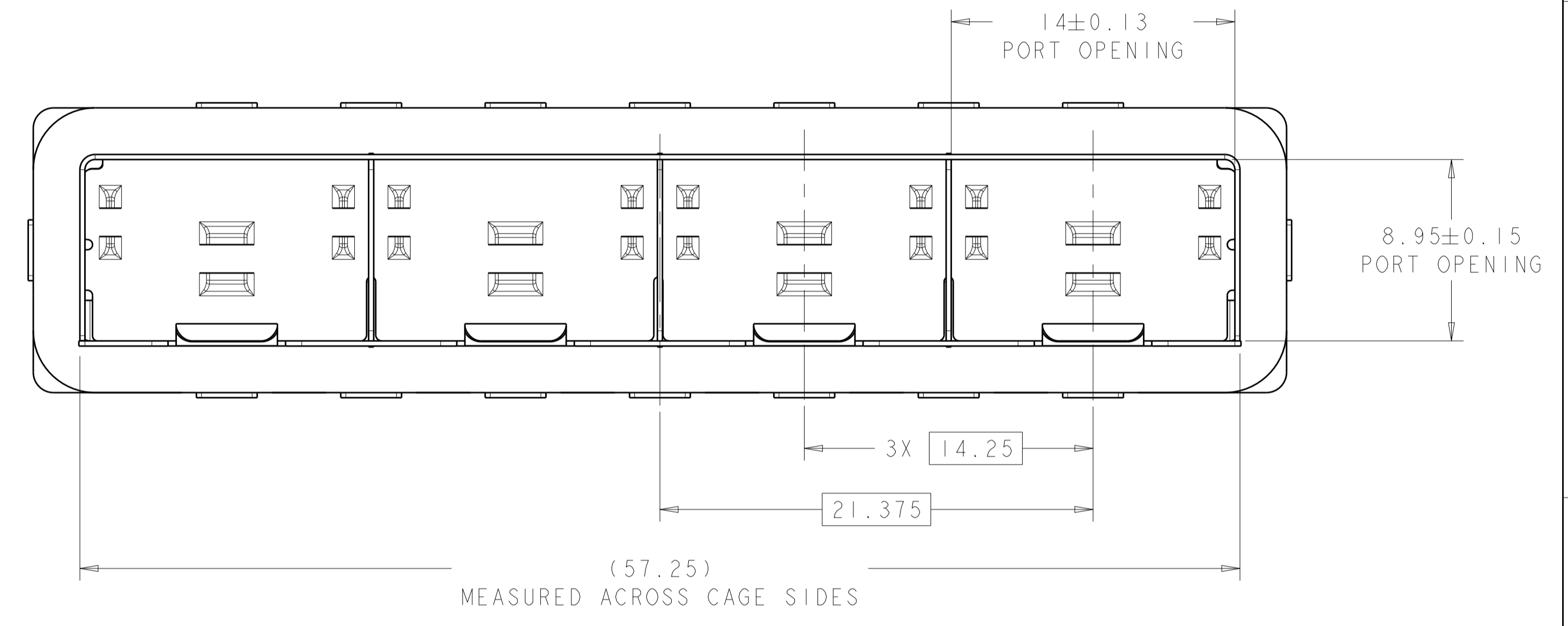
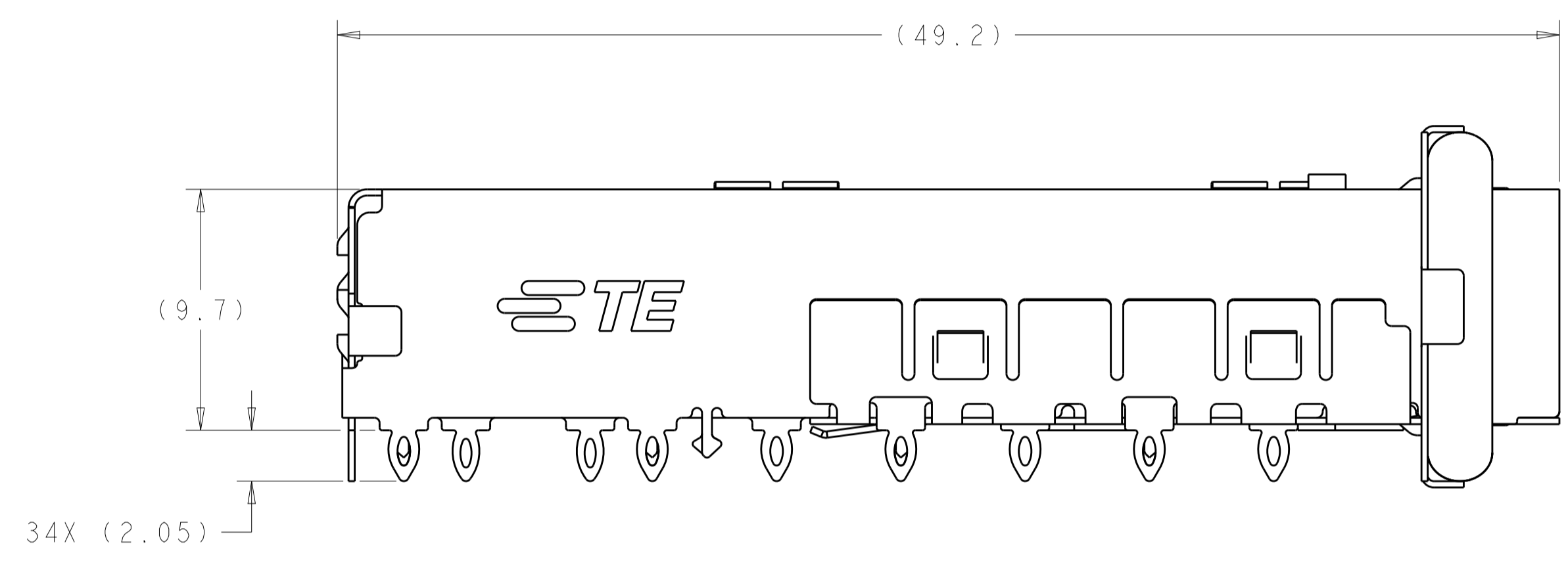

RECOMMENDED BEZEL CUT-OUT  
 SINGLE SIDED APPLICATIONS  
 SCALE 3:1

2169260-1  
 MOUNTED ON PC BOARD  
 SHOWN THRU RECOMMENDED BEZEL

2180463-1  
 PART NUMBER

THIS DRAWING IS A CONTROLLED DOCUMENT. DIMENSIONING AND TOLERANCING PER ASME Y14.5M-2009.		DWN B. MATTHEWS 18MAR2011	TE Connectivity
TOLERANCES UNLESS OTHERWISE SPECIFIED:		CHK M. SCHMITT 18MAR2011	
DIMENSIONS:	mm	APVD M. SCHMITT 18MAR2011	NAME
0 PLC	±0.1	PRODUCT SPEC	SFP+ ENHANCED 1X4 CAGE ASSEMBLY, PRESS FIT
1 PLC	±0.1	APPLICATION SPEC	108-2364
2 PLC	±0.1	114-13120	SIZE CAGE CODE DRAWING NO
3 PLC	±0.1	WEIGHT	A100779C=2180463
4 PLC	±0.1	Customer Drawing	RESTRICTED TO
ANGLES	±1°	SCALE 5:1	SHEET 1 OF 2
FINISH		REV B	

LOC	DIST	REV	DATE	APPV
GP	00			

REVISIONS		DATE	OWN	APPV
	SEE SHEET 1			

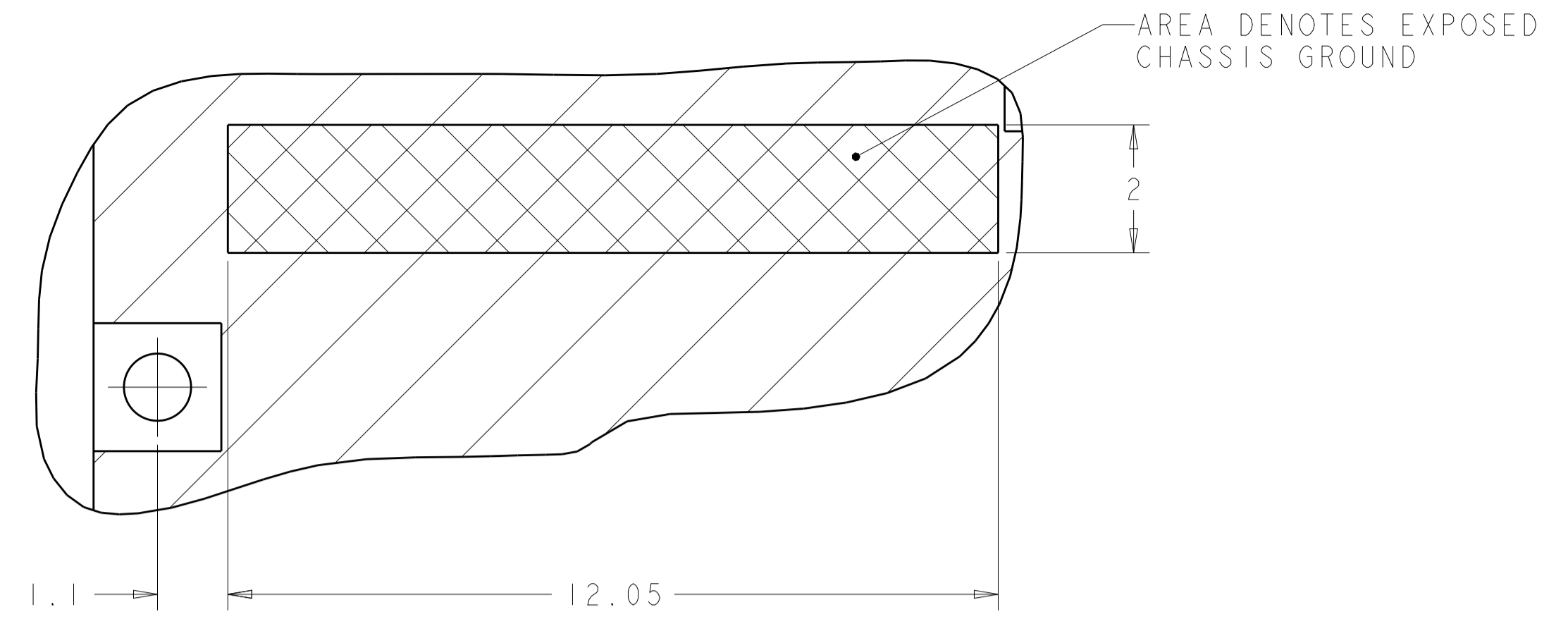

DETAIL A  
 4X INDIVIDUALLY  
 SCALE 12:1

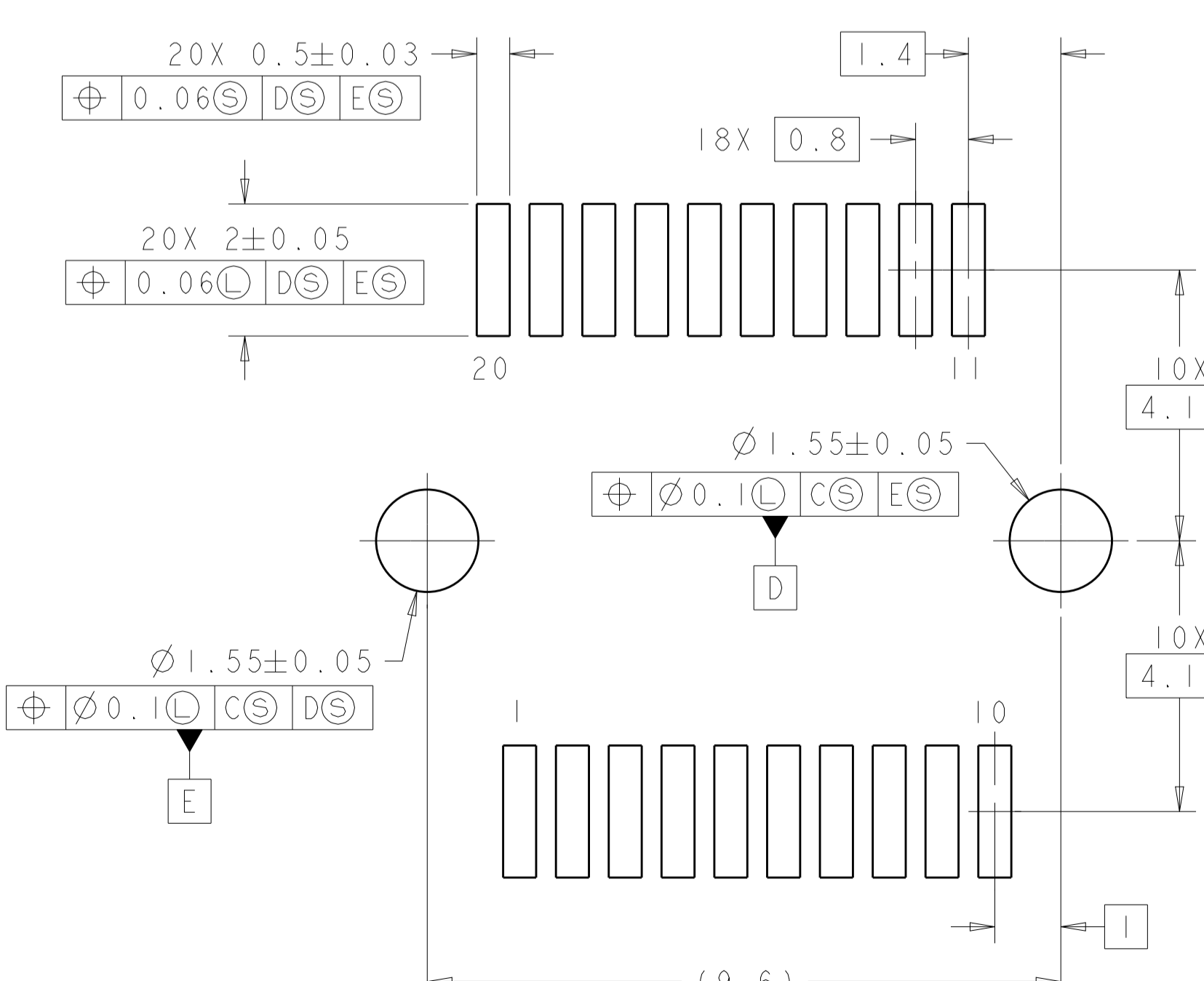
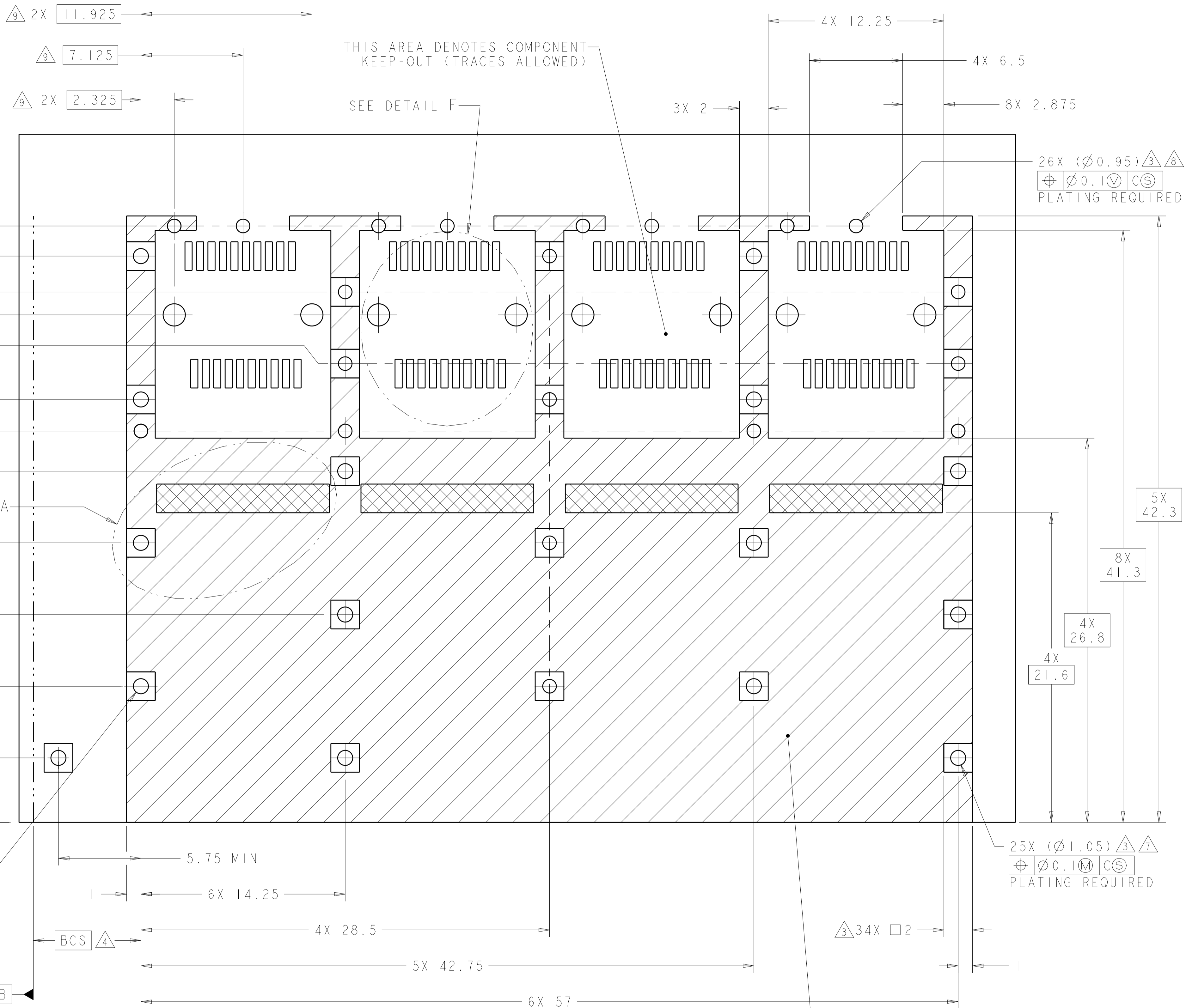

DETAIL F  
 RECOMMENDED PT CONNECTOR LAYOUT  
 4X INDIVIDUALLY  
 SCALE 12:1

THIS DRAWING IS A CONTROLLED DOCUMENT. DIMENSIONING AND TOLERANCING PER ASME Y14.5M-2009.		OWN: B. MATTHEWS (18MAR2011)	TE Connectivity
DIMENSIONS: mm		CHK: M. SCHMITT (18MAR2011)	NAME: SFP+ ENHANCED 1X4 CAGE ASSEMBLY, PRESS FIT
TOLERANCES UNLESS OTHERWISE SPECIFIED:		APPV: M. SCHMITT (18MAR2011)	SIZE: CAGE CODE DRAWING NO. RESTRICTED TO
0 PLC ±0.1	1 PLC ±0.1	PRODUCT SPEC: 108-2364	A100779C=2180463
2 PLC ±0.1	3 PLC ±0.1	APPLICATION SPEC: 114-13120	SCALE: 5:1 SHEET 2 OF 2 REV B
4 PLC ±0.1	ANGLES ±1°	WEIGHT: -	Customer Drawing