

FEATURES

Stereo, 24-bit analog-to-digital and digital-to-analog converters

DAC SNR: 100 dB (A-weighted), THD: -80 dB at 48 kHz, 3.3 V

ADC SNR: 90 dB (A-weighted), THD: -80 dB at 48 kHz, 3.3 V

Highly efficient headphone amplifier

Stereo line input and monaural microphone input

Low power

7 mW stereo playback (1.8 V/1.5 V supplies)

14 mW record and playback (1.8 V/1.5 V supplies)

Low supply voltages

Analog: 1.8 V to 3.6 V

Digital core: 1.5 V to 3.6 V

Digital I/O: 1.8 V to 3.6 V

256/384 oversampling rate in normal mode; 250/272 oversampling rate in USB mode

Audio sampling rates: 8 kHz, 11.025 kHz, 12 kHz, 16 kHz, 22.05 kHz, 24 kHz, 32 kHz, 44.1 kHz, 48 kHz, 88.2 kHz, and 96 kHz

28-lead, 5 mm × 5 mm LFCSP package

APPLICATIONS

Mobile phones

MP3 players

Portable gaming

Portable electronics

Educational toys

GENERAL DESCRIPTION

The SSM2602 is a low power, high quality stereo audio codec for portable digital audio applications with one set of stereo programmable gain amplifier (PGA) line inputs and one monaural microphone input. It features two 24-bit analog-to-digital converter (ADC) channels and two 24-bit digital-to-analog (DAC) converter channels.

The SSM2602 can operate as a master or a slave. It supports various master clock frequencies, including 12 MHz or 24 MHz for USB devices; standard 256 f_s or 384 f_s based rates, such as 12.288 MHz and 24.576 MHz; and many common audio sampling rates, such as 96 kHz, 88.2 kHz, 48 kHz, 44.1 kHz, 32 kHz, 24 kHz, 22.05 kHz, 16 kHz, 12 kHz, 11.025 kHz, and 8 kHz.

The SSM2602 can operate at power supplies as low as 1.8 V for the analog circuitry and as low as 1.5 V for the digital circuitry. The maximum voltage supply is 3.6 V for all supplies.

The SSM2602 software-programmable stereo output options provide the user with many application possibilities because the device can be used as a headphone driver or as a speaker driver. Its volume control functions provide a large range of gain control of the audio signal.

The SSM2602 is specified over the industrial temperature range of -40°C to +85°C. It is available in a 28-lead, 5 mm × 5 mm lead frame chip scale package (LFCSP).

FUNCTIONAL BLOCK DIAGRAM

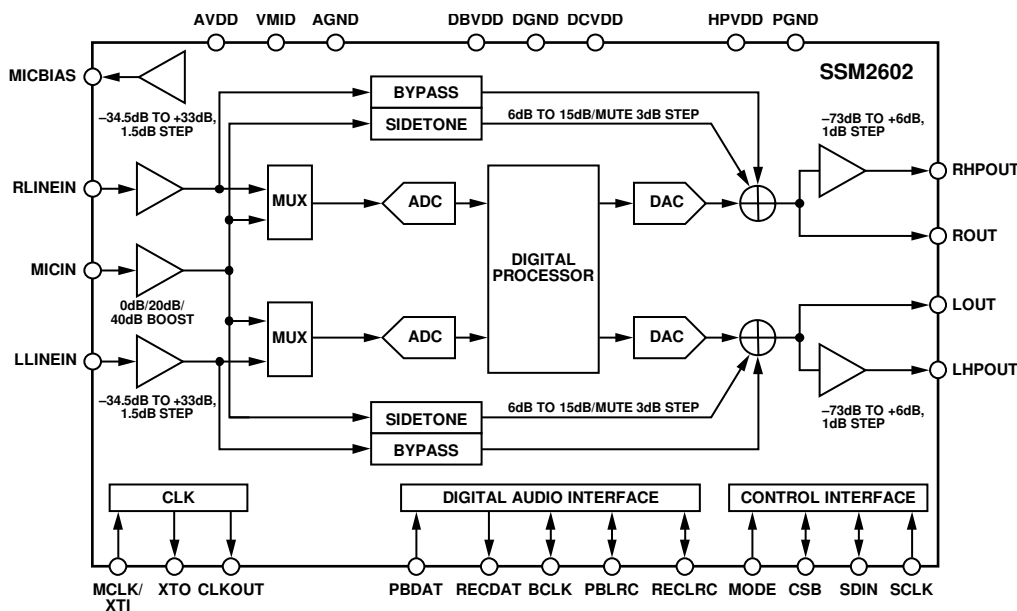

Figure 1.

Rev. B

[Document Feedback](#)

Information furnished by Analog Devices is believed to be accurate and reliable. However, no responsibility is assumed by Analog Devices for its use, nor for any infringements of patents or other rights of third parties that may result from its use. Specifications subject to change without notice. No license is granted by implication or otherwise under any patent or patent rights of Analog Devices. Trademarks and registered trademarks are the property of their respective owners.

TABLE OF CONTENTS

Features	1	Digital Audio Interface	16
Applications	1	Software Control Interface	18
General Description	1	Typical Application Circuits	19
Functional Block Diagram	1	Register Map	20
Revision History	2	Register Map Details	21
Specifications	3	Left-Channel ADC Input Volume, Address 0x00	21
Digital Filter Characteristics	4	Right-Channel ADC Input Volume, Address 0x01	22
Timing Characteristics	5	Left-Channel DAC Volume, Address 0x02	23
Absolute Maximum Ratings	8	Right-Channel DAC Volume, Address 0x03	23
Thermal Resistance	8	Analog Audio Path, Address 0x04	24
ESD Caution	8	Digital Audio Path Control, Address 0x05	24
Pin Configuration and Function Descriptions	9	Power Management, Address 0x06	25
Typical Performance Characteristics	10	Digital Audio I/F, Address 0x07	26
Converter Filter Response	10	Sampling Rate, Address 0x08	26
Digital De-Emphasis	11	Active, Address 0x09	29
Theory of Operation	12	Reset, Address 0x0F	29
Digital Core	12	ALC Control 1, Address 0x10	30
ADC and DAC	12	ALC Control 2, Address 0x11	30
ADC High Pass and DAC De-Emphasis Filters	12	Noise Gate, Address 0x12	31
Automatic Level Control (ALC)	13	Outline Dimensions	32
Analog Interface	14	Ordering Guide	32

REVISION HISTORY

8/2018—Rev. A to Rev. B

Changed CP-28-6 to CP-28-10	Universal
Change to Figure 7	9
Changes to Ordering Guide	32
Updated Outline Dimensions	32

10/2012—Rev. 0 to Rev. A

Changed CP-28-4 to CP-28-6	Universal
Added EPAD Notation	9
Updated Outline Dimensions	32
Changes to Ordering Guide	32

2/2008—Revision 0: Initial Version

SPECIFICATIONS

$T_A = 25^\circ\text{C}$, $AVDD = DVDD = 3.3\text{ V}$, $PVDD = 3.3\text{ V}$, 1 kHz signal, $f_s = 48\text{ kHz}$, PGA gain = 0 dB, 24-bit audio data, unless otherwise noted.

Table 1.

Parameter	Min	Typ	Max	Unit	Conditions
RECOMMENDED OPERATING CONDITIONS					
Analog Voltage Supply (AVDD)	1.8	3.3	3.6	V	
Digital Power Supply	1.5	3.3	3.6	V	
Ground (AGND, PGND, DGND)		0		V	
POWER CONSUMPTION					
Power-Up					
Stereo Record (1.5 V and 1.8 V)		7		mW	
Stereo Record (3.3 V)		22		mW	
Stereo Playback (1.5 V and 1.8 V)		7		mW	
Stereo Playback (3.3 V)		22		mW	
Power-Down			40	μW	
LINE INPUT					
Input Signal Level (0 dB)		$1 \times AVDD/3.3$		V rms	
Input Impedance		200		k Ω	PGA gain = 0 dB
		10		k Ω	PGA gain = +33 dB
		480		k Ω	PGA gain = -34.5 dB
Input Capacitance		10		pF	
Signal-to-Noise Ratio (A-Weighted)	70	90		dB	PGA gain = 0 dB, AVDD = 3.3 V
		84		dB	PGA gain = 0 dB, AVDD = 1.8 V
Total Harmonic Distortion (THD)		-80		dB	-1 dBFS input, AVDD = 3.3 V
		-75		dB	-1 dBFS input, AVDD = 1.8 V
Channel Separation		80		dB	
Programmable Gain	-34.5	0	+33.5	dB	
Gain Step		1.5		dB	
Mute Attenuation		-80		dB	
MICROPHONE INPUT					
Input Signal Level		1		V rms	
Signal-to-Noise Ratio (A-Weighted)		85		dB	Microphone gain = 0 dB ($R_{SOURCE} = 40\text{ k}\Omega$)
Total Harmonic Distortion		-70		dB	0 dBFS input, 0 dB gain
Power Supply Rejection Ratio		50		dB	
Mute Attenuation		80		dB	
Input Resistance		10		k Ω	
Input Capacitance		10		pF	
MICROPHONE BIAS					
Bias Voltage		$0.75 \times AVDD$		V	
Bias Current Source			3	mA	
Noise in the Signal Bandwidth		40		nV/ $\sqrt{\text{Hz}}$	20 Hz to 20 kHz
LINE OUTPUT					
DAC					-1 dBFS input DAC + line output
Full-Scale Output		$1 \times AVDD/3.3$		V rms	
Signal-to-Noise Ratio (A-Weighted)	85	100		dB	AVDD = 3.3 V
		94		dB	AVDD = 1.8 V
THD + N		-80	-70	dB	AVDD = 3.3 V
		-75		dB	AVDD = 1.8 V
Power Supply Rejection Ratio		50		dB	
Channel Separation		80		dB	

Parameter	Min	Typ	Max	Unit	Conditions
HEADPHONE OUTPUT					
Full-Scale Output Voltage		$1 \times AVDD/3.3$		V rms	
Maximum Output Power		30		mW	$R_L = 32 \Omega$
		60		mW	$R_L = 16 \Omega$
Signal-to-Noise Ratio (A-Weighted)	85	96		dB	$AVDD = 3.3 V$
		90			$AVDD = 1.8 V$
THD + N		-65		dB	$P_{OUT} = 10 mW$
		-60		dB	$P_{OUT} = 20 mW$
Power Supply Rejection Ratio		50		dB	
Mute Attenuation		80		dB	
LINE INPUT TO LINE OUTPUT					
Full-Scale Output Voltage		$1 \times AVDD/3.3$		V rms	
Signal-to-Noise Ratio (A-Weighted)		92		dB	$AVDD = 3.3 V$
		86			$AVDD = 1.8 V$
Total Harmonic Distortion		-80		dB	$AVDD = 3.3 V$
		-80			$AVDD = 1.8 V$
Power Supply Rejection		50		dB	
MICROPHONE INPUT TO HEADPHONE OUTPUT					
Full-Scale Output Voltage		$1 \times AVDD/3.3$		V rms	
Signal-to-Noise Ratio (A-Weighted)		94		dB	$AVDD = 3.3 V$
		88			$AVDD = 1.8 V$
Power Supply Rejection Ratio		50		dB	
Programmable Attenuation	6		15	dB	
Gain Step		3		dB	
Mute Attenuation		80		dB	

DIGITAL FILTER CHARACTERISTICS

Table 2.

Parameter	Min	Typ	Max	Unit	Conditions
ADC FILTER					
Pass Band	0		$0.445 f_s$	Hz	± 0.04 dB
		$0.5 f_s$		Hz	-6 dB
Pass-Band Ripple			± 0.04	dB	
Stop Band	$0.555 f_s$			Hz	
Stop-Band Attenuation	-61			dB	$f > 0.567 f_s$
High-Pass Filter Corner Frequency		3.7		Hz	-3 dB
		10.4		Hz	-0.5 dB
		21.6		Hz	-0.1 dB
DAC FILTER					
Pass Band	0		$0.445 f_s$	Hz	± 0.04 dB
		$0.5 f_s$		Hz	-6 dB
Pass-Band Ripple			± 0.04	dB	
Stop Band	$0.555 f_s$			Hz	
Stop-Band Attenuation	-61			dB	$f > 0.565 f_s$
Core Clock Tolerance					
Frequency Range	8.0		13.8	MHz	
Jitter Tolerance		50		ps	

TIMING CHARACTERISTICS

Table 3. I²C[®] Timing

Parameter	Limit		Unit	Description
	t _{MIN}	t _{MAX}		
t _{SCS}	600		ns	Start condition setup time
t _{SCH}	600		ns	Start condition hold time
t _{PH}	600		ns	SCLK pulse width high
t _{PL}	1.3		μs	SCLK pulse width low
f _{SCLK}	0	526	kHz	SCLK frequency
t _{DS}	100		ns	Data setup time
t _{DH}		900	ns	Data hold time
t _{RT}		300	ns	SDIN and SCLK rise time
t _{FT}		300	ns	SDIN and SCLK fall time
t _{HCS}	600		ns	Stop condition setup time

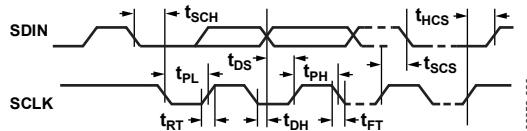

Figure 2. I²C Timing

Table 4. SPI Timing

Parameter	Limit		Unit	Description
	t _{MIN}	t _{MAX}		
t _{DSU}	20		ns	SDIN to SCLK setup time
t _{DHO}	20		ns	SCLK to SDIN hold time
t _{SCH}	20		ns	SCLK pulse width high
t _{SCL}	20		ns	SCLK pulse width low
t _{SCS}	60		ns	SCLK rising edge to CSB rising edge
t _{CSS}	20		ns	CSB rising to SCLK rising
t _{CSH}	20		ns	CSB pulse width high
t _{CSL}	20		ns	CSB pulse width low
t _{PS}	0	5	ns	Pulse width of spikes to be suppressed

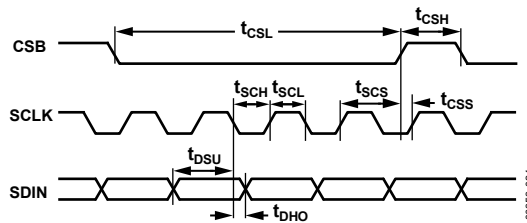

Figure 3. SPI Timing

Table 5. Digital Audio Interface Slave Mode Timing

Parameter	Limit		Unit	Description
	t _{MIN}	t _{MAX}		
t _{DS}	10	30	ns	PBDAT setup time from BCLK rising edge
t _{DH}	10		ns	PBDAT hold time from BCLK rising edge
t _{LRSU}	10		ns	RECLRC/PBLRC setup time to BCLK rising edge
t _{LRH}	10		ns	RECLRC/PBLRC hold time to BCLK rising edge
t _{DD}			ns	RECDAT propagation delay from BCLK falling edge (external load of 70 pF)
t _{BCH}	25		ns	BCLK pulse width high
t _{BCL}	25		ns	BCLK pulse width low
t _{BCY}	50		ns	BCLK cycle time

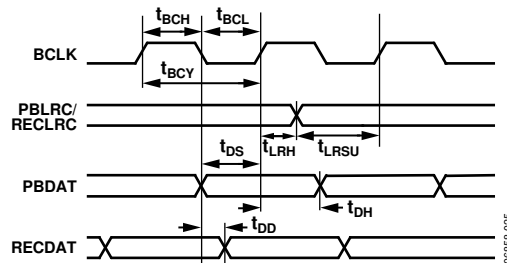

Figure 4. Digital Audio Interface Slave Mode Timing

Table 6. Digital Audio Interface Master Mode Timing

Parameter	Limit		Unit	Description
	t _{MIN}	t _{MAX}		
t _{DST}	30	10	ns	PBDAT setup time to BCLK rising edge
t _{DHT}	10		ns	PBDAT hold time to BCLK rising edge
t _{DL}		10	ns	RECLRC/PBLRC propagation delay from BCLK falling edge
t _{DDA}		10	ns	RECDAT propagation delay from BCLK falling edge
t _{BCLKR}	10		ns	BCLK rising time (10 pF load)
t _{BCLKF}	10		ns	BCLK falling time (10 pF load)
t _{BCLKDS}	45:55:00	55:45:00		BCLK duty cycle (normal and USB mode)

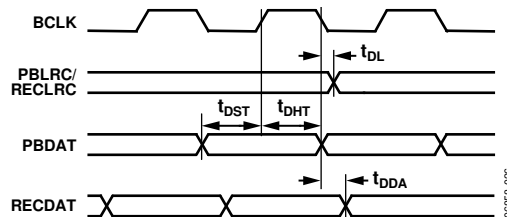

Figure 5. Digital Audio Interface Master Mode Timing

Table 7. System Clock Timing

Parameter	Limit		Unit	Description
	t _{MIN}	t _{MAX}		
t _{X_{TIY}}	72	60:40:00	ns	MCLK/X _{TI} system clock cycle time
t _{MCLKDS}	40:60		ns	MCLK/X _{TI} duty cycle
t _{X_{TIH}}	32		ns	MCLK/X _{TI} system clock pulse width high
t _{X_{TIL}}	32		ns	MCLK/X _{TI} system clock pulse width low
t _{COP}	20		ns	CLKOUT propagation delay from MCLK/X _{TI} falling edge
t _{COPDIV2}	20		ns	CLKODIV2 propagation delay from MCLK/X _{TI} falling edge

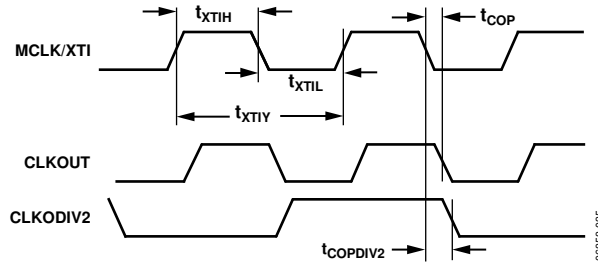

Figure 6. System (MCLK) Clock Timing

ABSOLUTE MAXIMUM RATINGS

At 25°C, unless otherwise noted.

Table 8.

Parameter	Rating
Supply Voltage	5 V
Input Voltage	V_{DD}
Common-Mode Input Voltage	V_{DD}
Storage Temperature Range	-65°C to +150°C
Operating Temperature Range	-40°C to +85°C
Junction Temperature Range	-65°C to +165°C
Lead Temperature (Soldering, 60 sec)	300°C

Stresses at or above those listed under Absolute Maximum Ratings may cause permanent damage to the product. This is a stress rating only; functional operation of the product at these or any other conditions above those indicated in the operational section of this specification is not implied. Operation beyond the maximum operating conditions for extended periods may affect product reliability.

THERMAL RESISTANCE

θ_{JA} is specified for the worst-case conditions, that is, a device soldered in a circuit board for surface-mount packages.

Table 9. Thermal Resistance

Package Type	θ_{JA}	θ_{JC}	Unit
28-Lead, 5 mm × 5 mm LFCSP	28	32	°C/W

ESD CAUTION



ESD (electrostatic discharge) sensitive device. Charged devices and circuit boards can discharge without detection. Although this product features patented or proprietary protection circuitry, damage may occur on devices subjected to high energy ESD. Therefore, proper ESD precautions should be taken to avoid performance degradation or loss of functionality.

PIN CONFIGURATION AND FUNCTION DESCRIPTIONS

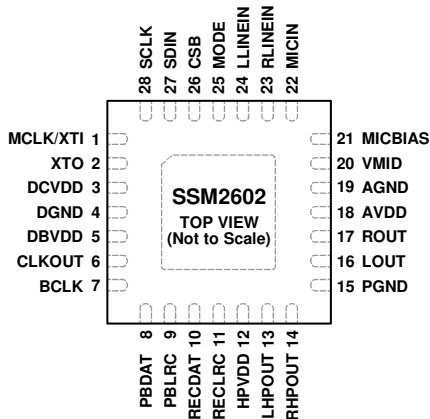

NOTES
1. THE EXPOSED PAD MUST BE CONNECTED TO GROUND.

06856-002

Figure 7. Pin Configuration

Table 10. Pin Function Descriptions

Pin No.	Mnemonic	Type	Description
1	MCLK/XTI	Digital Input	Master Clock Input/Crystal Input.
2	XTO	Digital Output	Crystal Output.
3	DCVDD	Digital Supply	Digital Core Supply.
4	DGND	Digital Ground	Digital Ground.
5	DBVDD	Digital Supply	Digital I/O Supply.
6	CLKOUT	Digital Output	Buffered Clock Output.
7	BCLK	Digital Input/Output	Digital Audio Bit Clock.
8	PBDAT	Digital Input	DAC Digital Audio Data Input, Playback Function.
9	PBLRC	Digital Input/Output	DAC Sampling Rate Clock, Playback Function (from Left and Right Channels).
10	RECDAT	Digital Output	ADC Digital Audio Data Output, Record Function.
11	RECLRC	Digital Input/Output	ADC Sampling Rate Clock, Record Function (from Left and Right Channels).
12	HPVDD	Analog Supply	Headphone Supply.
13	LHPOUT	Analog Output	Headphone Output for Left Channel.
14	RHPOUT	Analog Output	Headphone Output for Right Channel.
15	PGND	Analog Ground	Headphone Ground.
16	LOUT	Analog Output	Line Output for Left Channel.
17	ROUT	Analog Output	Line Output for Right Channel.
18	AVDD	Analog Supply	Analog Supply.
19	AGND	Analog Ground	Analog Ground.
20	VMID	Analog Output	Midrail Voltage Decoupling Input.
21	MICBIAS	Analog Output	Microphone Bias.
22	MICIN	Analog Input	Microphone Input Signal.
23	RLINEIN	Analog Input	Line Input for Right Channel.
24	LLINEIN	Analog Input	Line Input for Left Channel.
25	MODE	Digital Input	Control Interface Selection to Select I ² C/SPI.
26	CSB	Digital Input	3-Wire Control Interface Chip Selection, Active Low/2-Wire Control Interface I ² C Address Selection.
27	SDIN	Digital Input/Output	3-Wire Control Interface Data Input/2-Wire Control Interface Data Input/Output.
28	SCLK	Digital Input	3-Wire/2-Wire Control Interface Clock Input.
	EPAD	Thermal Pad	Exposed Pad. The exposed pad must be connected to ground.

TYPICAL PERFORMANCE CHARACTERISTICS

CONVERTER FILTER RESPONSE

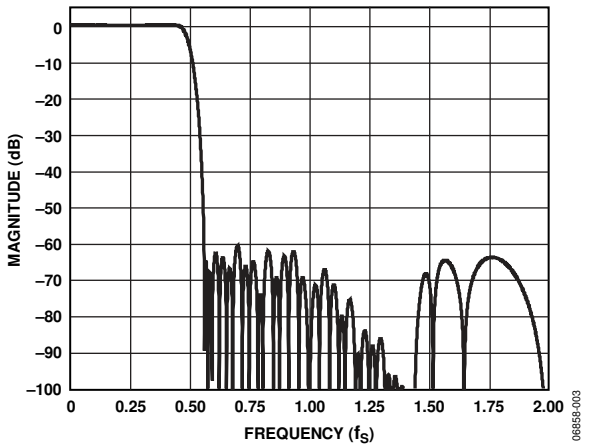

Figure 8. ADC Digital Filter Frequency Response

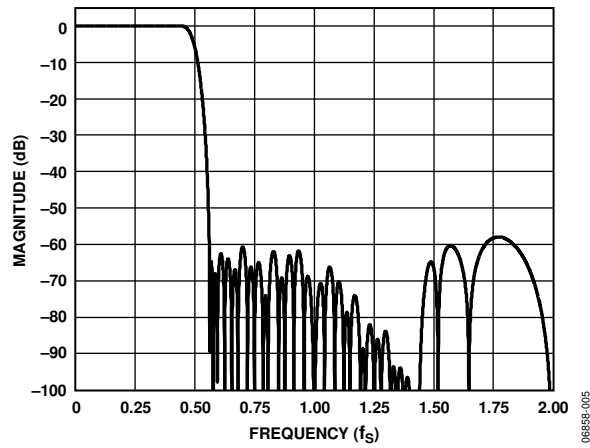

Figure 10. DAC Digital Filter Frequency Response

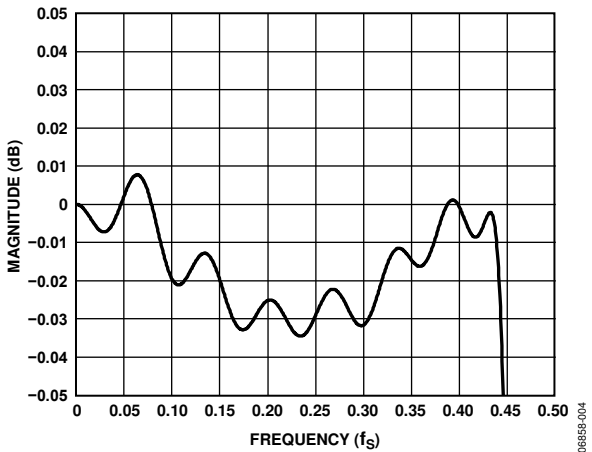

Figure 9. ADC Digital Filter Ripple

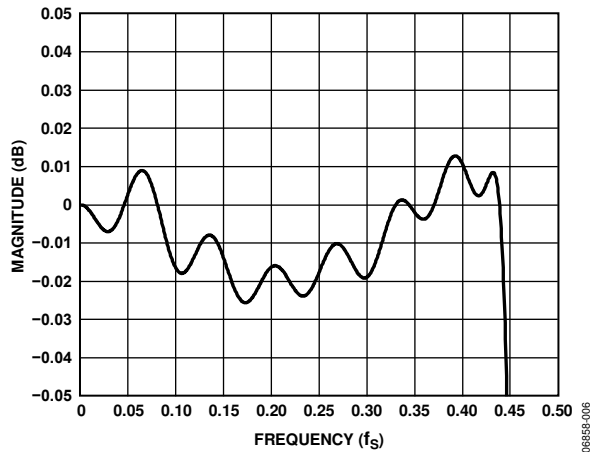

Figure 11. DAC Digital Filter Ripple

DIGITAL DE-EMPHASIS

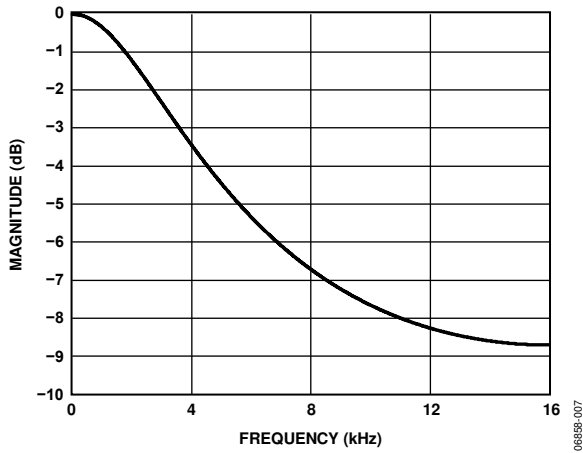

Figure 12. De-Emphasis Frequency Response, Audio Sampling Rate = 32 kHz

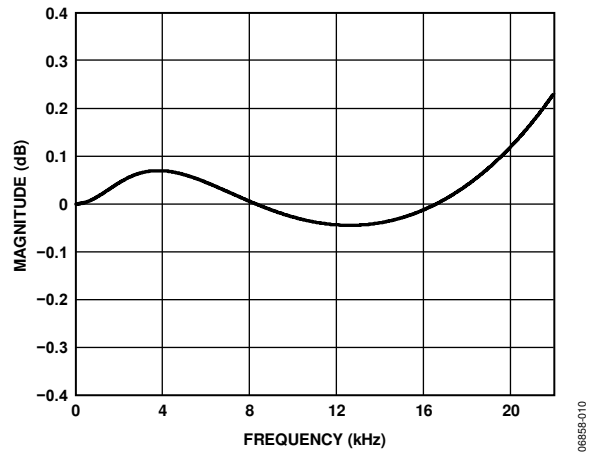

Figure 15. De-Emphasis Error, Audio Sampling Rate = 44.1 kHz

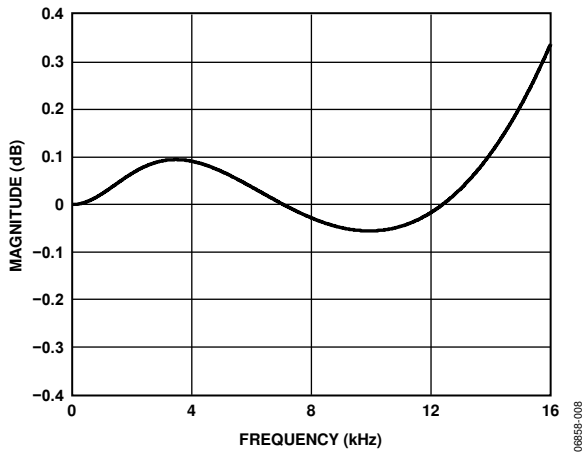

Figure 13. De-Emphasis Error, Audio Sampling Rate = 32 kHz

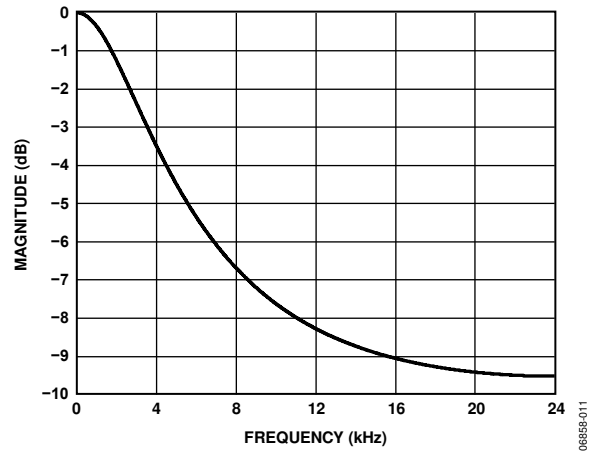

Figure 16. De-Emphasis Frequency Response, Audio Sampling Rate = 48 kHz

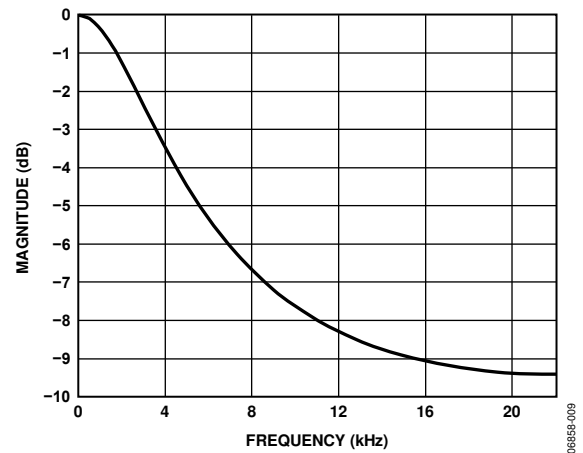

Figure 14. De-Emphasis Frequency Response, Audio Sampling Rate = 44.1 kHz

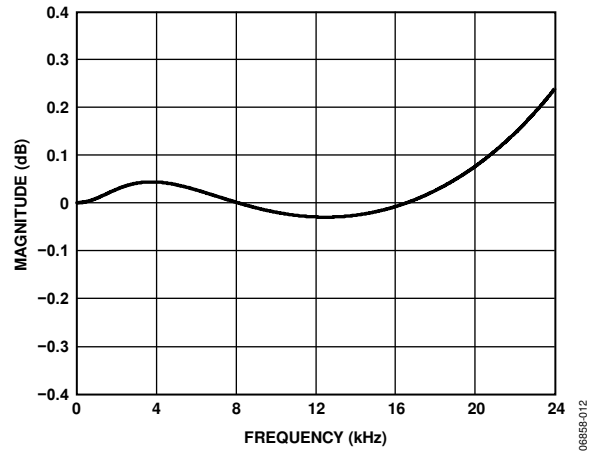

Figure 17. De-Emphasis Error, Audio Sampling Rate = 48 kHz

THEORY OF OPERATION

DIGITAL CORE

Inside the SSM2602 digital core is one central clock source, called the master clock (MCLK), that produces a reference clock for all internal audio data processing and synchronization.

When using an external clock source to drive the MCLK pin, great care should be taken to select a clock source with less than 50 ps of jitter. Without careful generation of the MCLK signal, the digital audio quality will most likely suffer.

To enable the SSM2602 to generate the central reference clock in a system, connect a crystal oscillator between the MCLK/XTI input pin and the XTO output pin.

To allow an external device to generate the central reference clock, apply the external clock signal directly through the MCLK/XTI input pin. In this configuration, the oscillator circuit of the SSM2602 can be powered down by using the OSC bit (Register R6, Bit D5) to reduce power consumption.

To accommodate applications with very high frequency master clocks, the internal core reference clock of the SSM2602 can be set to either MCLK or MCLK divided by 2. This is enabled by adjusting the setting of the CLKDIV2 bit (Register R8, Bit D6). Complementary to this feature, the CLKOUT pin can also drive external clock sources with either the core clock signal or core clock divided by 2 by enabling the CLKODIV2 bit (Register R8, Bit D7).

ADC AND DAC

The SSM2602 contains a pair of oversampling Σ - Δ ADCs. The maximum ADC full-scale input level is 1.0 V rms when AVDD = 3.3 V. If the input signal to the ADC exceeds this level, data overloading occurs and causes audible distortion.

The ADC can accept analog audio input from either the stereo line inputs or the monaural microphone input. Note that the ADC can only accept input from a single source, so the user

must choose either the line inputs or the microphone input as the source using the INSEL bit (Register R4, Bit D2). The digital data from the ADC output, once converted, is processed using the ADC filters.

Complementary to the ADC channels, the SSM2602 contains a pair of oversampling Σ - Δ DACs that convert the digital audio data from the internal DAC filters into an analog audio signal. The DAC output can also be muted by setting the DACMU bit (Register R5, Bit D3) in the control register.

ADC HIGH-PASS AND DAC DE-EMPHASIS FILTERS

The ADC and DAC employ separate digital filters that perform 24-bit signal processing. The digital filters are used for both record and playback modes and are optimized for each individual sampling rate used.

For recording mode operations, the unprocessed data from the ADC enters the ADC filters and is converted to the appropriate sampling frequency, and then is output to the digital audio interface.

For playback mode operations, the DAC filters convert the digital audio interface data to oversampled data, using a sampling rate selected by the user. The oversampled data is processed by the DAC and then is sent to the analog output mixer by enabling the DACSEL (Register R4, Bit D4).

Users have the option of setting up the device so that any dc offset in the input source signal is automatically detected and removed. To accomplish this, enable the digital high-pass filter (see Table 2 for characteristics) contained in the ADC digital filters by using the ADCHPF bit (Register R5, Bit D0).

In addition, users can implement digital de-emphasis by using the DEEMPH bits (Register R5, Bit D1 and Bit D2).

AUTOMATIC LEVEL CONTROL (ALC)

The SSM2602 codec has an automatic level control (ALC) that can be activated to suppress clipping and improve dynamic range even if a sudden, loud input signal is introduced. This is achieved by continuously adjusting the PGA gain so that the signal level at the ADC input remains constant.

Decay (Gain Ramp-Up) Time

Decay time is the time taken for the PGA gain to ramp up to 90% of its range. The time for the recording level to return to its target value, therefore, depends on both the decay time and the gain adjustment required. If the gain adjustment is small, the time to return to the target value will be less than the decay time.

Attack (Gain Ramp-Down) Time

Attack time is the time taken for the PGA gain to ramp down through 90% of its range. The time for the recording level to

return to its target value, therefore, depends on both the attack time and the gain adjustment required. If the gain adjustment is small, the time to return to the target value will be less than the attack time.

Noise Gate

When the ALC function is enabled but the input signal is silent for long periods, an audible hissing sound may be introduced by a phenomenon called noise pumping. To prevent this occurrence, the SSM2602 employs a noise gate function. A user-selected threshold can be set by using the NGTH bits (Register R18, Bit D3 to Bit D7). When the noise gate is enabled, the ADC output is either muted or held at a constant gain to prevent the noise-pumping phenomenon. For more information about the noise gate settings, see Table 42.

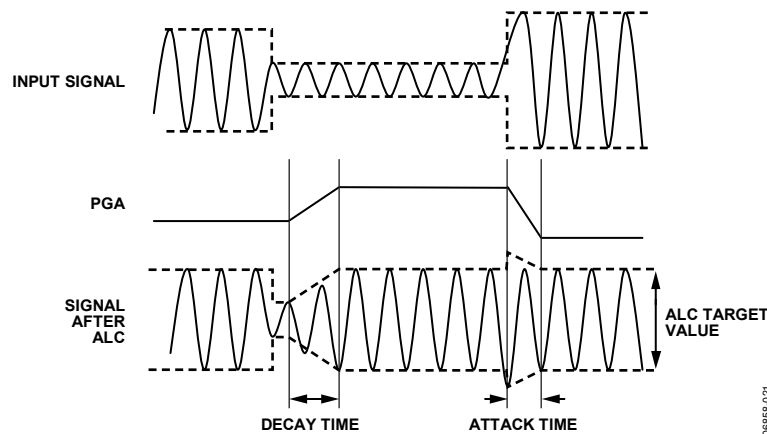

Figure 18. PGA and ALC Decay Time and Attack Time Definitions

06856-0/21

ANALOG INTERFACE

Signal Chain

The SSM2602 includes stereo single-ended line and monaural microphone inputs to the on-board ADC. Either the line inputs or the microphone input, but not both simultaneously, can be connected to the ADC by setting the INSEL bit (Register R4, Bit D2). In addition, the line or microphone inputs can be routed and mixed directly to the output terminals via the SIDETONE_EN (Register R4, Bit D5) and BYPASS (Register R4, Bit D3) bits. The SSM2602 also includes line and headphone outputs from the on-board DAC.

Stereo Line and Monaural Microphone Inputs

The SSM2602 contains a set of single-ended stereo line inputs (RLINEIN and LLINEIN) that are internally biased to VMID by way of a voltage divider between AVDD and AGND. The line input signal can be connected to the internal ADC and, if desired, routed directly to the outputs via the bypass path by using the BYPASS bit (Register R4, Bit D3).

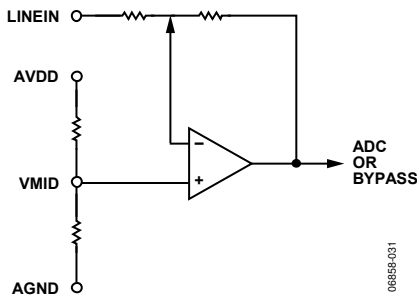

Figure 19. Line Input to ADC

The line input volume can be adjusted from -34.5 dB to $+33$ dB in steps of $+1.5$ dB by setting the LINVOL (Register R0, Bit D0 to Bit D5) and RINVOL (Register R1, Bit D0 to Bit D5) bits. Volume control, by default, is independently adjustable on both right and left line inputs. However, the LRINBOTH or RLINBOTH bit, if selected, simultaneously loads both sets of volume control with the same value. The user can also set the LINMUTE (Register R0, Bit D7) and RINMUTE (Register R1, Bit D7) bits to mute the line input signal to the ADC.

The high impedance, low capacitance monaural microphone input pin (MICIN) has two gain stages and a microphone bias level (MICBIAS) that is internally biased to the VMID voltage level by way of a voltage divider between AVDD and AGND. The microphone input signal can be connected to the internal ADC and, if desired, routed directly to the outputs via the sidetone path by using the SIDETONE_EN bit (Register R4, Bit D5).

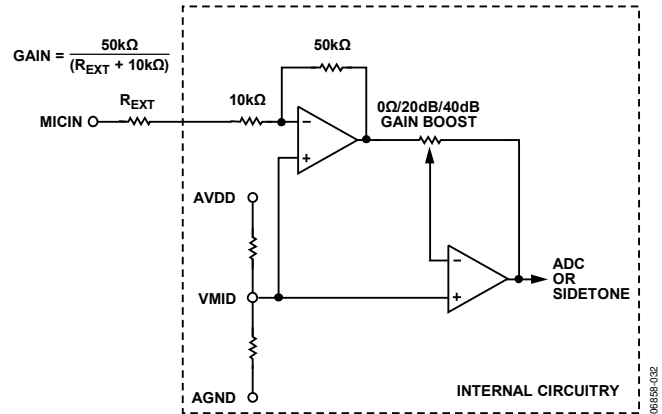

Figure 20. Microphone Input to ADC

The first gain stage is composed of a low noise operational amplifier set to an inverting configuration with integrated 50 k Ω feedback and 10 k Ω input resistors. The default microphone input signal gain is 14 dB. An external resistor (R_{EXT}) can be connected in series with the MICIN pin to reduce the first-stage gain of the microphone input signal to as low as 0 dB by using the following equation:

$$\text{Microphone Input Gain} = 50 \text{ k}\Omega / (10 \text{ k}\Omega + R_{EXT})$$

The second-stage gain of the microphone signal path is derived from the internal microphone boost circuitry. The available settings are 0 dB, 20 dB, and 40 dB and are controlled by the MICBOOST (Register R4, Bit D0) and MICBOOST2 (Register R4, Bit D8) bits. To achieve 20 dB of secondary gain boost, the user can select either MICBOOST or MICBOOST2. To achieve 40 dB of secondary microphone signal gain, the user must select both MICBOOST and MICBOOST2.

In similar functionality to the line inputs, the user can set the MUTEMIC bit (Register R4, Bit D1) to mute the microphone input signal to the ADC.

Note that when sourcing audio data from both line and microphone inputs, the maximum full-scale input of the ADC is 1.0 V rms when $AVDD = 3.3$ V. Do not source any input voltage larger than full scale to avoid overloading the ADC, which causes distortion of sound and deterioration of audio quality. For best sound quality in both microphone and line inputs, gain should be carefully configured so that the ADC receives a signal equal to its full scale. This maximizes the signal-to-noise ratio for best total audio quality.

Bypass and Sidetone Paths to Output

The line and microphone inputs can be routed and mixed directly to the output terminals via the SIDETONE_EN (Register R4, Bit D5) and BYPASS (Register R4, Bit D3) software control register selections. In both of these modes, the analog input signal is routed directly to the output terminals and is not digitally converted. The bypass signal at the output mixer is the same level as the output of the PGA associated with each line input.

The sidetone signal at the output mixer must be attenuated by a range of -6 dB to -15 dB in steps of -3 dB by configuring the SIDETONE_ATT (Register R4, Bit D6 and Bit D7) control register bits. The selected level of attenuation occurs after the initial microphone signal amplification from the microphone first- and second-stage gains.

Line and Headphone Outputs

The DAC outputs, the microphone (the sidetone path), and the line inputs (the bypass path) are summed at an output mixer. This output signal can be present at both the stereo line outputs and stereo headphone outputs.

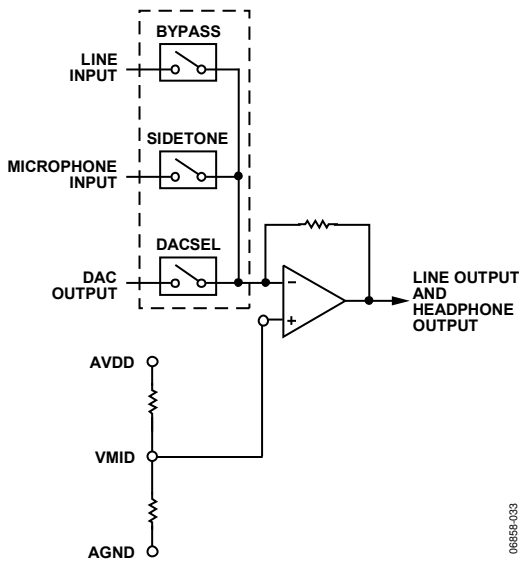

Figure 21. Output Signal Chain

The SSM2602 has a set of efficient headphone amplifier outputs, LHPOUT and RHPOUT, that are able to drive 16 Ω or 32 Ω headphone speakers.

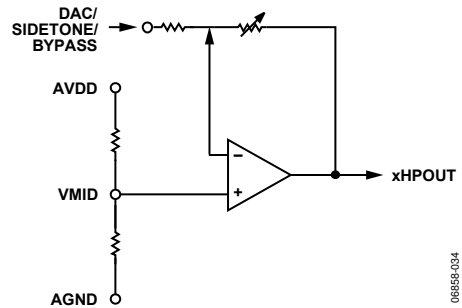

Figure 22. Headphone Output

In similar functionality to the line inputs, the LHPOUT and RHPOUT volumes, by default, are independently adjusted by setting the LHPVOL (Register R2, Bit D0 to Bit D6) and RHPVOL (Register R3, Bit D0 to Bit D6) bits of the headphone output control registers. The headphone outputs can be muted by writing codes less than 0110000 to the LHPVOL and RHPVOL bits. The user is also able to simultaneously load the volume control of both channels by writing to the LRHPBOTH (Register R2, Bit D8) and RLHPBOTH (Register R3, Bit D8) bits of the left- and right-channel DAC volume registers.

The maximum output level of the headphone outputs is 1.0 V rms when AVDD and HPVDD = 3.3 V. To suppress audible pops and clicks, the headphone and line outputs are held at the VMID dc voltage level when the device is set to standby mode or in the event that the headphone outputs are muted.

The stereo line outputs of the SSM2602, the LOUT and ROUT pins, are able to drive a load impedance of 10 kΩ and 50 pF. The line output signal levels are not adjustable at the output mixer, having a fixed gain of 0 dB. The maximum output level of the line outputs is 1.0 V rms when AVDD = 3.3 V.

DIGITAL AUDIO INTERFACE

The digital audio input can support the following four digital audio communication protocols: right-justified mode, left-justified mode, I²S mode, and digital-signal processor (DSP) mode.

The mode selection is performed by writing to the FORMAT bits of the digital audio interface register (Register R7, Bit D1 and Bit D0). All modes are MSB first and operate with data of 16 to 32 bits.

Recording Mode

On the RECDAT output pin, the digital audio interface can send digital audio data for recording mode operation. The digital audio interface outputs the processed internal ADC digital filter data onto the RECDAT output. The digital audio data stream on RECDAT comprises left- and right-channel audio data that is time domain multiplexed.

The RECLRC is the digital audio frame clock signal that separates left- and right-channel data on the RECDAT lines.

The BCLK signal acts as the digital audio clock. Depending on if the SSM2602 is in master or slave mode, the BCLK signal is either an input or an output signal. During a recording operation, RECDAT and RECLRC must be synchronous to the BCLK signal to avoid data corruption.

Playback Mode

On the PBDAT input pin, the digital audio interface can receive digital audio data for playback mode operation. The digital audio data stream on PBDAT comprises left- and right-channel audio data that is time domain multiplexed. The PBLRC is the digital audio frame clock signal that separates left- and right-channel data on the PBDAT lines.

The BCLK signal acts as the digital audio clock. Depending on if the SSM2602 is in master or slave mode, the BCLK signal is either an input or an output signal. During a playback operation, PBDAT and PBLRC must be synchronous to the BCLK signal to avoid data corruption.

Digital Audio Data Sampling Rate

To accommodate a wide variety of commonly used DAC and ADC sampling rates, the SSM2602 allows for two modes of operation, normal and USB, selected by the USB bit (Register R8, Bit D0).

In normal mode, the SSM2602 supports digital audio sampling rates from 8 kHz to 96 kHz. Normal mode supports 256 f_s and 384 f_s based clocks. To select the desired sampling rate, the user must set the appropriate sampling rate register in the SR control bits (Register R8, Bit D2 to Bit D5) and match this selection to the core clock frequency that is pulsed on the MCLK pin. See Table 30 and Table 31 for guidelines.

In USB mode, the SSM2602 supports digital audio sampling rates from 8 kHz to 96 kHz. USB mode is enabled on the SSM2602 to support the common universal serial bus (USB) clock rate of 12 MHz, or to support 24 MHz if the CLKDIV2 control register bit is activated. The user must set the appropriate sampling rate in the SR control bits (Register R8, Bit D2 to Bit D5). See Table 30 and Table 31 for guidelines.

Note that the sampling rate is generated as a fixed divider from the MCLK signal. Because all audio processing references the core MCLK signal, corruption of this signal, in turn, corrupts the outgoing audio quality of the SSM2602. The BCLK/RECLRC/RECDAT or BCLK/PBLRC/PBDAT signals must be synchronized with MCLK in the digital audio interface circuit. MCLK must be faster or equal to the BCLK frequency to guarantee that no data is lost during data synchronization.

The BCLK frequency should be greater than

$$\text{Sampling Rate} \times \text{Word Length} \times 2$$

Ensuring that the BCLK frequency is greater than this value guarantees that all valid data bits are captured by the digital audio interface circuitry. For example, if a 32 kHz digital audio sampling rate with a 32-bit word length is desired, BCLK ≥ 2.048 MHz.

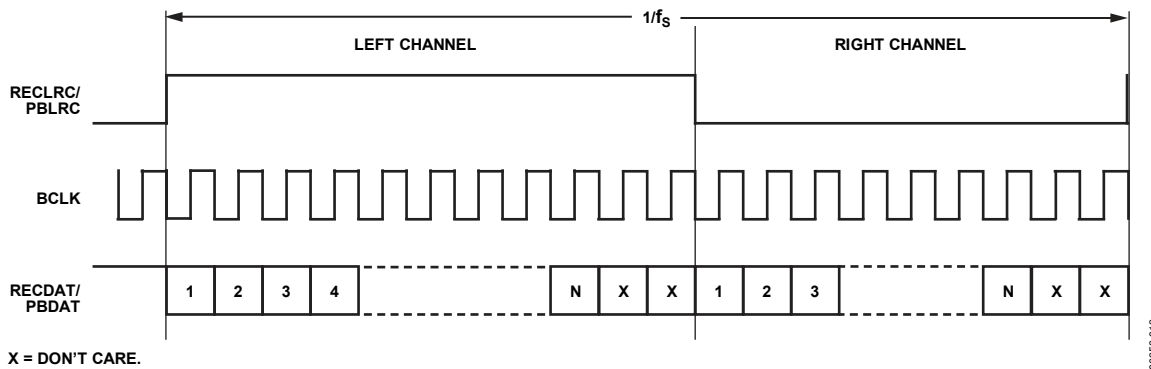

Figure 23. Left-Justified Audio Input Mode

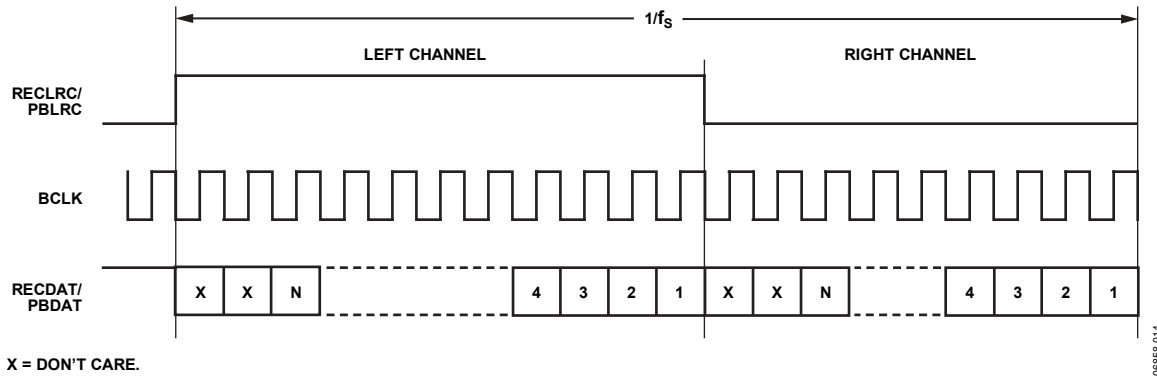

Figure 24. Right-Justified Audio Input Mode

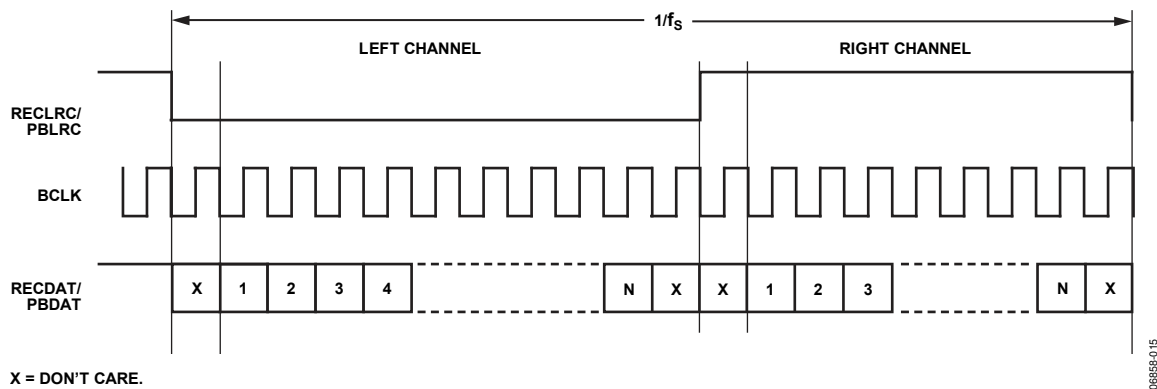

Figure 25. I^S Audio Input Mode

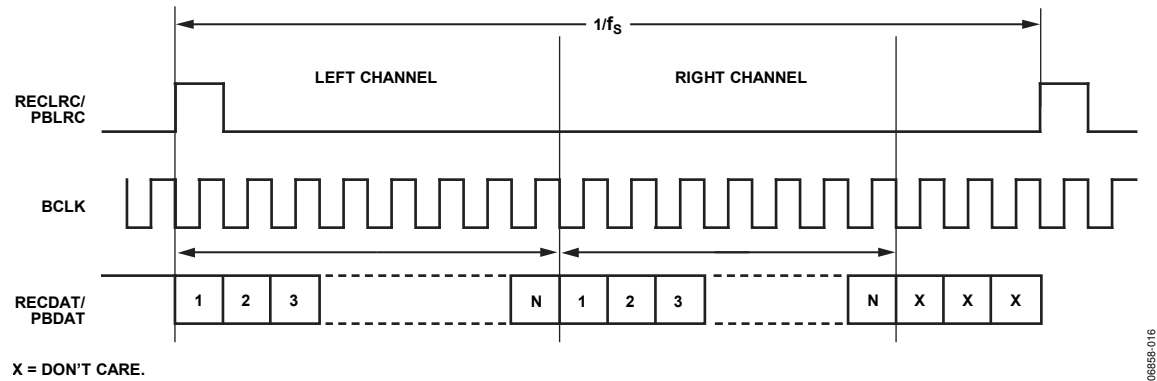

Figure 26. DSP/Pulse Code Modulation (PCM) Mode Audio Input Submode 1 (SM1) [Bit LRP = 0]

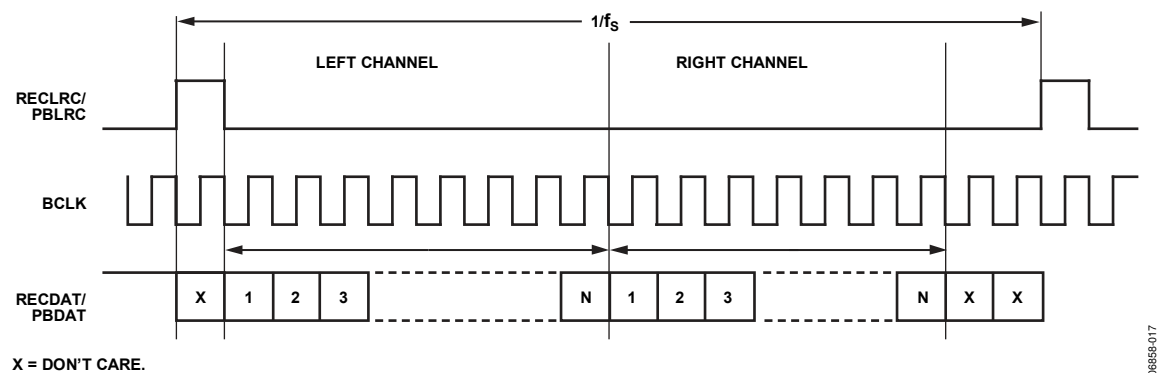

Figure 27. DSP/PCM Mode Audio Input Submode 2 (SM2) [Bit LRP = 1]

SOFTWARE CONTROL INTERFACE

The software control interface provides access to the user-selectable control registers and can operate with a 2-wire (I²C) or 3-wire (SPI) interface, depending on the setting of the MODE pin. If the MODE pin is set to 0, the 2-wire interface is selected; if 1, the 3-wire interface is selected.

Within each control register is a control data-word consisting of 16 bits, MSB first. Bit B15 to Bit B9 are the register map address, and Bit B8 to Bit B0 are register data for the associated register map.

When 2-wire (I²C) mode is selected, SDIN generates the serial control data-word, SCLK clocks the serial data, and CSB determines the I²C device address. If the CSB pin is set to 0, the address selected is 0011010; if 1, the address is 0011011.

When 3-wire (SPI) mode is selected, SDIN generates the control data-word, SCLK clocks the control data-word into the SSM2602, and CSB latches in the control data-word.

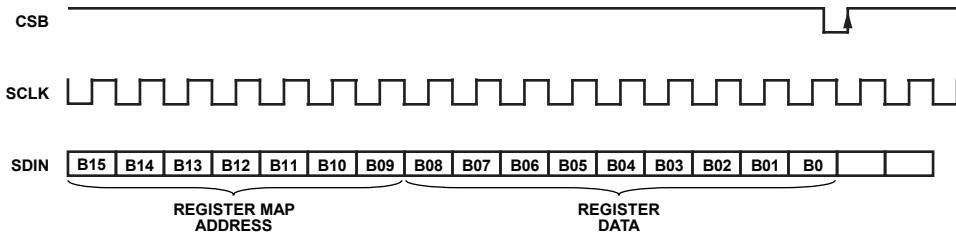

Figure 28. SPI Serial Interface

06859-019

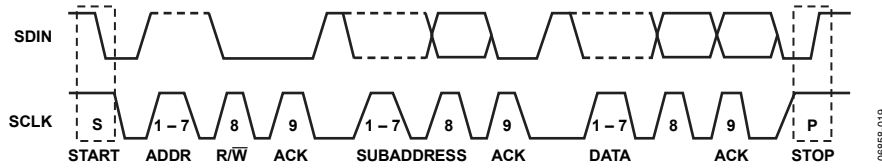
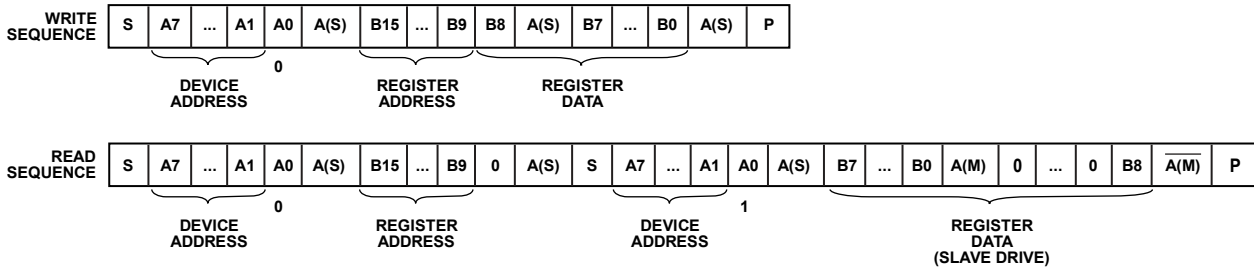

Figure 29. SSM2602 2-Wire I²C Generalized Clocking Diagram

06859-019



S/P = START/STOP BIT.
 A0 = I²C R/W BIT.
 A(S) = ACKNOWLEDGE BY SLAVE.
 A(M) = ACKNOWLEDGE BY MASTER.
 A(M) = ACKNOWLEDGE BY MASTER (INVERSION).

Figure 30. SSM2602 I²C Write and Read Sequences

06859-022

TYPICAL APPLICATION CIRCUITS

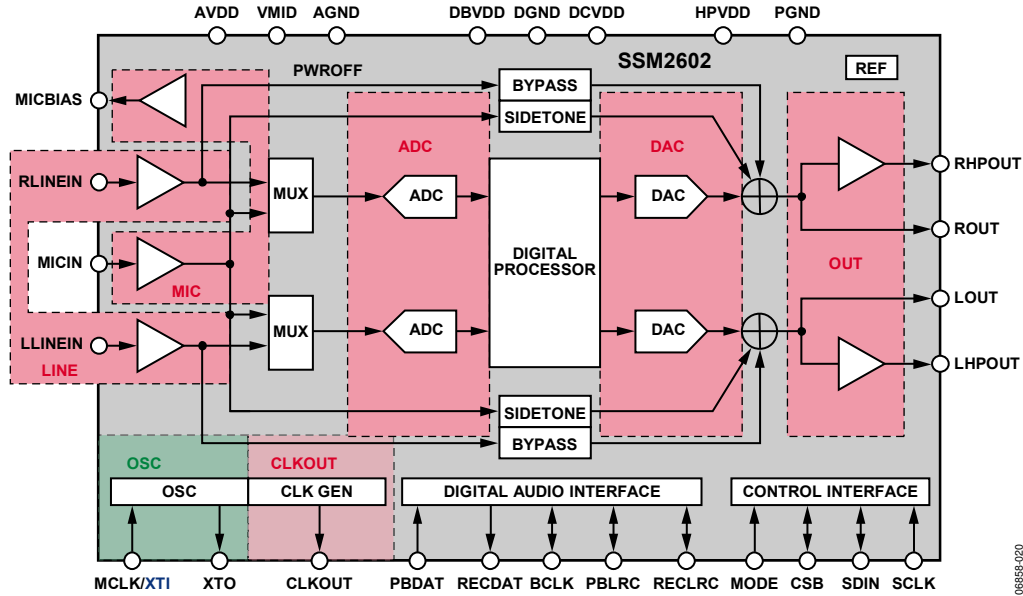

Figure 31. SSM2602 Power Management Functional Location Diagram (Control Register R6, Bit D0 to Bit D7)

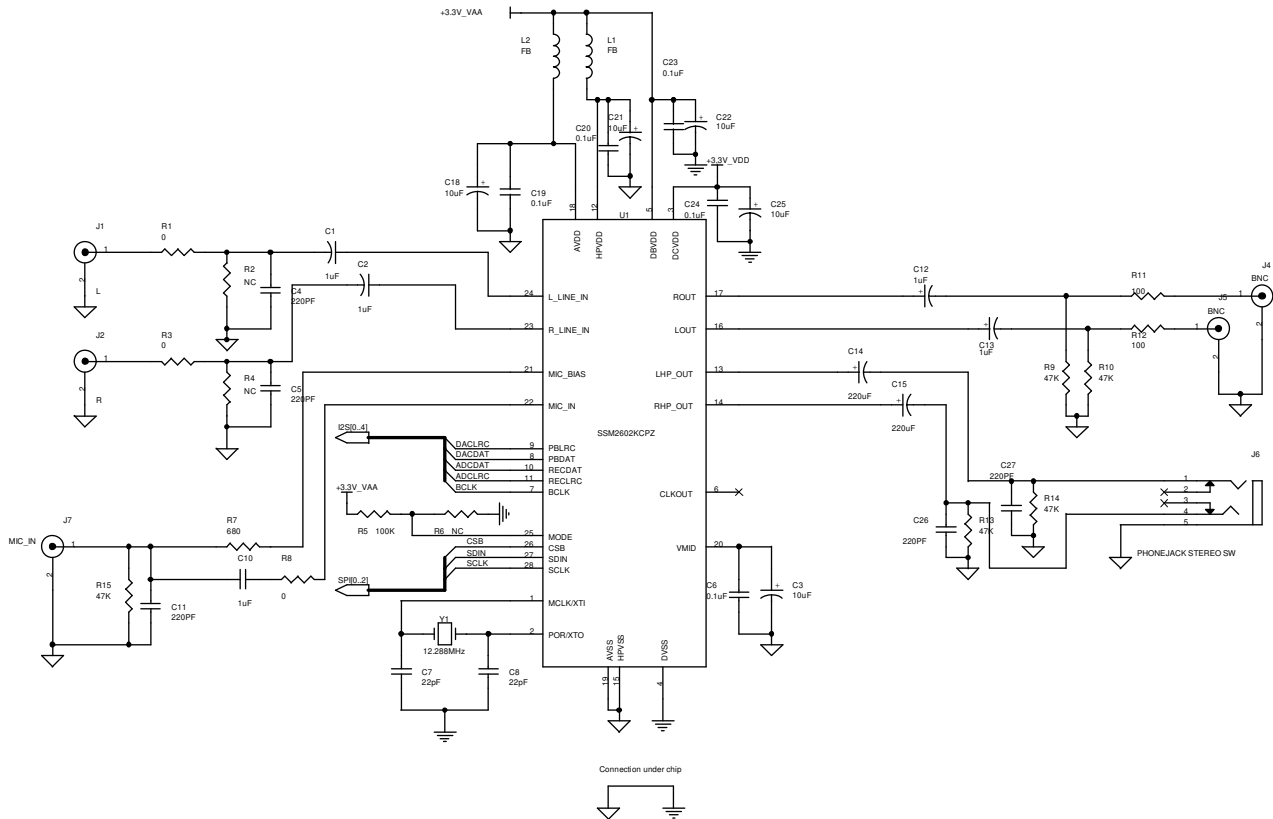

Figure 32. SSM2602 Typical Application Circuit

REGISTER MAP

Table 11. Register Map

Reg.	Address	Name	D8	D7	D6	D5	D4	D3	D2	D1	D0	Default
R0	0x00	Left-Channel ADC Input Volume	LRINBOTH	LINMUTE	0	LINVOL [5:0]					010010111	
R1	0x01	Right-Channel ADC Input Volume	RLINBOTH	RINMUTE	0	RINVOL [5:0]					010010111	
R2	0x02	Left-Channel DAC Volume	LRHPBOTH	LZCEN	LHPVOL [6:0]					001111001		
R3	0x03	Right-Channel DAC Volume	RLHPBOTH	RZCEN	RHPVOL [6:0]					001111001		
R4	0x04	Analog Audio Path	MICBOOST2	SIDETONE_ATT [1:0]	SIDETONE_EN	DACSEL	BYPASS	INSEL	MUTEMIC	MICBOOST	000001010	
R5	0x05	Digital Audio Path	0	0	0	0	HPOR	DACMU	DEEMPH [1:0]		ADCHPF	000001000
R6	0x06	Power Management	0	PWROFF	CLKOUT	OSC	OUT	DAC	ADC	MIC	LINEIN	010011111
R7	0x07	Digital Audio I/F	0	BCLKINV	MS	LRSWAP	LRP	WL [1:0]		FORMAT [1:0]		000001010
R8	0x08	Sampling Rate	0	CLKODIV2	CLKDIV2	SR [3:0]			BOSR	USB	000000000	
R9	0x09	Active	0	0	0	0	0	0	0	0	ACTIVE	000000000
R15	0x0F	Software Reset	RESET [8:0]								000000000	
R16	0x10	ALC Control 1	ALCSEL [1:0]		MAXGAIN [2:0]			ALCL [3:0]			001111011	
R17	0x11	ALC Control 2	0	DCY [3:0]			ATK [3:0]			000110010		
R18	0x12	Noise Gate	0	NGTH [4:0]				NGG [1:0]		NGAT	000000000	

REGISTER MAP DETAILS

LEFT-CHANNEL ADC INPUT VOLUME, ADDRESS 0x00

Table 12. Left-Channel ADC Input Volume Register Bit Map

D8	D7	D6	D5	D4	D3	D2	D1	D0
LRINBOTH	LINMUTE	0	LINVOL [5:0]					

Table 13. Descriptions of Left-Channel ADC Input Volume Register Bits

Bit Name	Description	Settings
LRINBOTH	Left-to-right line input ADC data load control	0 = disable simultaneous loading of left-channel ADC data to right-channel register (default) 1 = enable simultaneous loading of left-channel ADC data to right-channel register
LINMUTE	Left-channel input mute	0 = disable mute 1 = enable mute on data path to ADC (default)
LINVOL [5:0]	Left-channel PGA volume control	00 0000 = -34.5 dB ... 1.5 dB step up 01 0111 = 0 dB (default) ... 1.5 dB step up 01 1111 = 12 dB 10 0000 = 13.5 dB 10 0001 = 15 dB 10 0010 = 16.5 dB 10 0011 = 18 dB 10 0100 = 19.5 dB 10 0101 = 21 dB 10 0110 = 22.5 dB 10 0111 = 24 dB 10 1000 = 25.5 dB 10 1001 = 27 dB 10 1010 = 28.5 dB 10 1011 = 30 dB 10 1100 = 31.5 dB 10 1101 = 33 dB 11 1111 to 10 1101 = 33 dB

RIGHT-CHANNEL ADC INPUT VOLUME, ADDRESS 0x01

Table 14. Right-Channel ADC Input Volume Register Bit Map

D8	D7	D6	D5	D4	D3	D2	D1	D0
RLINBOTH	RINMUTE	0	RINVOL [5:0]					

Table 15. Descriptions of Right-Channel ADC Input Volume Register Bits

Bit Name	Description	Settings
RLINBOTH	Right-to-left line input ADC data load control	0 = disable simultaneous loading of right-channel ADC data to left-channel register (default) 1 = enable simultaneous loading of right-channel ADC data to left-channel register
RINMUTE	Right-channel input mute	0 = disable mute 1 = enable mute on data path to ADC (default)
RINVOL [5:0]	Right-channel PGA volume control	00 0000 = -34.5 dB ... 1.5 dB step up 01 0111 = 0 dB (default) ... 1.5 dB step up 01 1111 = 12 dB 10 0000 = 13.5 dB 10 0001 = 15 dB 10 0010 = 16.5 dB 10 0011 = 18 dB 10 0100 = 19.5 dB 10 0101 = 21 dB 10 0110 = 22.5 dB 10 0111 = 24 dB 10 1000 = 25.5 dB 10 1001 = 27 dB 10 1010 = 28.5 dB 10 1011 = 30 dB 10 1100 = 31.5 dB 10 1101 = 33 dB 11 1111 to 10 1101 = 33 dB

LEFT-CHANNEL DAC VOLUME, ADDRESS 0x02

Table 16. Left-Channel DAC Volume Register Bit Map

D8	D7	D6	D5	D4	D3	D2	D1	D0
LRHPBOTH	LZCEN	LHPVOL [6:0]						

Table 17. Descriptions of Left-Channel DAC Volume Register Bits

Bit Name	Description	Settings
LRHPBOTH	Left-to-right headphone volume load control	0 = disable simultaneous loading of left-channel headphone volume data to right-channel register (default) 1 = enable simultaneous loading of left-channel headphone volume data to right-channel register
LZCEN	Left-channel zero cross detect enable	0 = disable (default) 1 = enable
LHPVOL [6:0]	Left-channel headphone volume control	000 0000 to 010 1111 = mute 011 0000 = -73 dB ... 111 1001 = 0 dB (default) ... 1 dB steps up to 111 1111 = +6 dB

RIGHT-CHANNEL DAC VOLUME, ADDRESS 0x03

Table 18. Right-Channel DAC Volume Register Bit Map

D8	D7	D6	D5	D4	D3	D2	D1	D0
RLHPBOTH	RZCEN	RHPVOL [6:0]						

Table 19. Descriptions of Right-Channel DAC Volume Register Bits

Bit Name	Description	Settings
RLHPBOTH	Right-to-left headphone volume load control	0 = disable simultaneous loading of right-channel headphone volume data to left-channel register (default) 1 = enable simultaneous loading of right-channel headphone volume data to left-channel register
RZCEN	Right-channel zero cross detect enable	0 = disable (default) 1 = enable
RHPVOL [6:0]	Right-channel headphone volume control	000 0000 to 010 1111 = mute 011 0000 = -73 dB ... 111 1001 = 0 dB (default) ... 1 dB steps up to 111 1111 = +6 dB

ANALOG AUDIO PATH, ADDRESS 0x04

Table 20. Analog Audio Path Register Bit Map

D8	D7	D6	D5	D4	D3	D2	D1	D0
MICBOOST2	SIDETONE_ATT [1:0]		SIDETONE_EN	DACSEL	BYPASS	INSEL	MUTEMIC	MICBOOST

Table 21. Descriptions of Analog Audio Path Register Bits

Bit Name	Description	Settings
MICBOOST2	Additional microphone amplifier gain booster control.	0 = 0 dB (default) 1 = 20 dB
SIDETONE_ATT [1:0]	Microphone sidetone gain control.	00 = -6 dB (default) 01 = -9 dB 10 = -12 dB 11 = -15 dB
SIDETONE_EN	Sidetone enable. Allow attenuated microphone signal to be mixed at device output terminal.	0 = sidetone disable (default) 1 = sidetone enable
DACSEL	DAC select. Allow DAC output to be mixed at device output terminal.	0 = do not select DAC (default) 1 = select DAC
BYPASS	Bypass select. Allow line input signal to be mixed at device output terminal.	0 = bypass disable 1 = bypass enable (default)
INSEL	Line input or microphone input select to ADC.	0 = line input select to ADC (default) 1 = microphone input select to ADC
MUTEMIC	Microphone mute control to ADC.	0 = mute on data path to ADC disable 1 = mute on data path to ADC enable (default)
MICBOOST	Primary microphone amplifier gain booster control.	0 = 0 dB (default) 1 = 20 dB

DIGITAL AUDIO PATH, ADDRESS 0x05

Table 22. Digital Audio Path Register Bit Map

D8	D7	D6	D5	D4	D3	D2	D1	D0
0	0	0	0	HPOR	DACMU	DEEMPH [1:0]		ADCHPF

Table 23. Descriptions of Digital Audio Path Register Bits

Bit Name	Description	Settings
HPOR	Store dc offset when high-pass filter is disabled	0 = clear offset (default) 1 = store offset
DACMU	DAC digital mute	0 = no mute (signal active) 1 = mute (default)
DEEMPH [1:0]	De-emphasis control	00 = no de-emphasis (default) 01 = 32 kHz sampling rate 10 = 44.1 kHz sampling rate 11 = 48 kHz sampling rate
ADCHPF	ADC high-pass filter control	0 = ADC high-pass filter enable (default) 1 = ADC high-pass filter disable

POWER MANAGEMENT, ADDRESS 0x06**Table 24. Power Management Register Bit Map**

D8	D7	D6	D5	D4	D3	D2	D1	D0
0	PWROFF	CLKOUT	OSC	OUT	DAC	ADC	MIC	LINEIN

Table 25. Description of Power Management Register Bits

Bit Name	Description	Settings
PWROFF	Whole chip power-down control	0 = power up 1 = power down (default)
CLKOUT	Clock output power-down control	0 = power up (default) 1 = power down
OSC	Crystal power-down control	0 = power up (default) 1 = power down
OUT	Output power-down control	0 = power up 1 = power down (default)
DAC	DAC power-down control	0 = power up 1 = power down (default)
ADC	ADC power-down control	0 = power up 1 = power down (default)
MIC	Microphone input power-down control	0 = power up 1 = power down (default)
LINEIN	Line input power-down control	0 = power up 1 = power down (default)

Power Consumption**Table 26.**

Mode	PWROFF	CLKOUT	OSC	OUT	DAC	ADC	MIC	LINEIN	AVDD (3.3V)	HPVDD (3.3 V)	DCVDD (3.3 V)	DBVDD (3.3 V)	Unit
Record and Playback	0	0	0	0	0	0	0	0	10.7	2.2	3.6	3.1	mA
Playback Only													
Oscillator Enabled	0	0	0	0	0	1	1	1	5.2	2.2	1.7	1.8	mA
External Clock	0	1	1	0	0	1	1	1	5.1	2.2	1.7	1.7	mA
Record Only													
Line Clock	0	0	0	1	1	0	1	0	4.7	N/A	2.0	1.9	mA
Line Oscillator	0	0	1	1	1	0	1	0	4.7	N/A	2.0	1.8	mA
Microphone 1	0	0	0	1	1	0	0	1	4.8	N/A	2.0	1.9	mA
Microphone 2	0	0	1	1	1	0	0	1	4.8	N/A	2.0	1.8	mA
Sidetone (Microphone-to- Headphone Output)													
External Clock	0	0	1	0	1	1	0	1	2.0	2.2	0.2	1.7	mA
Internally Generated Clock	0	0	1	0	1	1	0	1	2.0	2.2	0.2	1.7	mA
Analog Bypass (Line Input or Line Output)													
External Line	0	0	1	0	1	1	1	0	2.0	2.2	0.2	1.7	mA
Internally Generated Line	0	0	1	0	1	1	1	0	2.0	2.2	0.2	1.7	mA
Power-Down													
External Clock Oscillator	1	1	1	1	1	1	1	1	0.001	<1uA	0.03	0.03	mA
Oscillator	1	1	1	1	1	1	1	1	0.001	<1uA	0.03	0.03	mA

DIGITAL AUDIO I/F, ADDRESS 0x07

Table 27. Digital Audio I/F Register Bit Map

D8	D7	D6	D5	D4	D3	D2	D1	D0
0	BCLKINV	MS	LRSWAP	LRP	WL [1:0]		FORMAT [1:0]	

Table 28. Descriptions of Digital Audio I/F Register Bits

Bit Name	Description	Settings
BCLKINV	BCLK inversion control	0 = BCLK not inverted (default) 1 = BCLK inverted
MS	Master mode enable	0 = enable slave mode (default) 1 = enable master mode
LRSWAP	Swap DAC data control	0 = output left- and right-channel data as normal (default) 1 = swap left- and right-channel DAC data in audio interface
LRP	Polarity control for clocks in right-justified, left-justified, and I ² S modes	0 = normal PBLRC and RECLRC (default), or DSP Submode 1 1 = invert PBLRC and RECLRC polarity, or DSP Submode 2
WL [1:0]	Data-word length control	00 = 16 bits 01 = 20 bits 10 = 24 bits (default) 11 = 32 bits
FORMAT [1:0]	Digital audio input format control	00 = right justified 01 = left justified 10 = I ² S mode (default) 11 = DSP mode

SAMPLING RATE, ADDRESS 0x08

Table 29. Sampling Rate Register Bit Map

D8	D7	D6	D5	D4	D3	D2	D1	D0
0	CLKODIV2	CLKDIV2	SR [3:0]			BOSR	USB	

Table 30. Descriptions of Sampling Rate Register Bits

Bit Name	Description	Settings
CLKODIV2	CLKOUT divider select	0 = CLKOUT is core clock (default) 1 = CLKOUT is core clock divided by 2
CLKDIV2	Core clock divide select	0 = core clock is MCLK (default) 1 = core clock is MCLK divided by 2
SR [3:0]	Clock setting condition	See Table 31 and Table 32.
BOSR	Base oversampling rate	USB mode: 0 = support for 250 f _s based clock (default) 1 = support for 272 f _s based clock Normal mode: 0 = support for 256 f _s based clock (default) 1 = support for 384 f _s based clock
USB	USB mode select	0 = normal mode enable (default) 1 = USB mode enable

Table 31. Sampling Rate Lookup Table, USB Disabled (Normal Mode)

MCLK (CLKDIV2 = 0)	MCLK (CLKDIV2 = 1)	ADC Sampling Rate (RECLRC)	DAC Sampling Rate (PBLRC)	USB	SR [3:0]	BOSR	BCLK (MS = 1) ¹
12.288 MHz	24.576 MHz	8 kHz (MCLK/1536)	8 kHz (MCLK/1536)	0	0011	0	MCLK/4
		8 kHz (MCLK/1536)	48 kHz (MCLK/256)	0	0010	0	MCLK/4
		12 kHz (MCLK/1024)	12 kHz (MCLK/1024)	0	0100	0	MCLK/4
		16 kHz (MCLK/768)	16 kHz (MCLK/768)	0	0101	0	MCLK/4
		24 kHz (MCLK/512)	24 kHz (MCLK/512)	0	1110	0	MCLK/4
		32 kHz (MCLK/384)	32 kHz (MCLK/384)	0	0110	0	MCLK/4
		48 kHz (MCLK/256)	8 kHz (MCLK/1536)	0	0001	0	MCLK/4
		48 kHz (MCLK/256)	48 kHz (MCLK/256)	0	0000	0	MCLK/4
		96 kHz (MCLK/128)	96 kHz (MCLK/128)	0	0111	0	MCLK/2
11.2896 MHz	22.5792 MHz	8.0182 kHz (MCLK/1408)	8.0182 kHz (MCLK/1408)	0	1011	0	MCLK/4
		8.0182 kHz (MCLK/1408)	44.1 kHz (MCLK/256)	0	1010	0	MCLK/4
		11.025 kHz (MCLK/1024)	11.025 kHz (MCLK/1024)	0	1100	0	MCLK/4
		22.05 kHz (MCLK/512)	22.05 kHz (MCLK/512)	0	1101	0	MCLK/4
		44.1 kHz (MCLK/256)	8.0182 kHz (MCLK/1408)	0	1001	0	MCLK/4
		44.1 kHz (MCLK/256)	44.1 kHz (MCLK/256)	0	1000	0	MCLK/4
		88.2 kHz (MCLK/128)	88.2 kHz (MCLK/128)	0	1111	0	MCLK/2
18.432 MHz	36.864 MHz	8 kHz (MCLK/2304)	8 kHz (MCLK/2304)	0	0011	1	MCLK/6
		8 kHz (MCLK/2304)	48 kHz (MCLK/384)	0	0010	1	MCLK/6
		12 kHz (MCLK/1536)	12 kHz (MCLK/1536)	0	0100	1	MCLK/6
		16 kHz (MCLK/1152)	16 kHz (MCLK/1152)	0	0101	1	MCLK/6
		24 kHz (MCLK/768)	24 kHz (MCLK/768)	0	1110	1	MCLK/6
		32 kHz (MCLK/576)	32 kHz (MCLK/576)	0	0110	1	MCLK/6
		48 kHz (MCLK/384)	48 kHz (MCLK/384)	0	0000	1	MCLK/6
		48 kHz (MCLK/384)	8 kHz (MCLK/2304)	0	0001	1	MCLK/6
		96 kHz (MCLK/192)	96 kHz (MCLK/192)	0	0111	1	MCLK/3
16.9344 MHz	33.8688 MHz	8.0182 kHz (MCLK/2112)	8.0182 kHz (MCLK/2112)	0	1011	1	MCLK/6
		8.0182 kHz (MCLK/2112)	44.1 kHz (MCLK/384)	0	1010	1	MCLK/6
		11.025 kHz (MCLK/1536)	11.025 kHz (MCLK/1536)	0	1100	1	MCLK/6
		22.05 kHz (MCLK/768)	22.05 kHz (MCLK/768)	0	1101	1	MCLK/6
		44.1 kHz (MCLK/384)	8.0182 kHz (MCLK/2112)	0	1001	1	MCLK/6
		44.1 kHz (MCLK/384)	44.1 kHz (MCLK/384)	0	1000	1	MCLK/6
		88.2 kHz (MCLK/192)	88.2 kHz (MCLK/192)	0	1111	1	MCLK/3

¹ BCLK frequency is for master mode and slave right-justified mode only.

Table 32. Sampling Rate Lookup Table, USB Enabled (USB Mode)

MCLK (CLKDIV2 = 0)	MCLK (CLKDIV2 = 1)	ADC Sampling Rate (RECLRC)	DAC Sampling Rate (PBLRC)	USB	SR [3:0]	BOSR	BCLK (MS = 1) ¹
12.000 MHz	24.000 MHz	8 kHz (MCLK/1500)	8 kHz (MCLK/1500)	1	0011	0	MCLK
		8 kHz (MCLK/1500)	48 kHz (MCLK/250)	1	0010	0	MCLK
		8.0214 kHz (MCLK/1496)	8.0214 kHz (MCLK/1496)	1	1011	1	MCLK
		8.0214 kHz (MCLK/1496)	44.118 kHz (MCLK/272)	1	1010	1	MCLK
		11.0259 kHz (MCLK/1088)	11.0259 kHz (MCLK/1088)	1	1100	1	MCLK
		12 kHz (MCLK/1000)	12 kHz (MCLK/1000)	1	1000	0	MCLK
		16 kHz (MCLK/750)	16 kHz (MCLK/750)	1	1010	0	MCLK
		22.0588 kHz (MCLK/544)	22.0588 kHz (MCLK/544)	1	1101	1	MCLK
		24 kHz (MCLK/500)	24 kHz (MCLK/500)	1	1110	0	MCLK
		32 kHz (MCLK/375)	32 kHz (MCLK/375)	1	0110	0	MCLK
		44.118 kHz (MCLK/272)	8.0214 kHz (MCLK/1496)	1	1001	1	MCLK
		44.118 kHz (MCLK/272)	44.118 kHz (MCLK/272)	1	1000	1	MCLK
		48 kHz (MCLK/250)	8 kHz (MCLK/1500)	1	0001	0	MCLK
		48 kHz (MCLK/250)	48 kHz (MCLK/250)	1	0000	0	MCLK
		88.235 kHz (MCLK/136)	88.235 kHz (MCLK/136)	1	1111	1	MCLK
		96 kHz (MCLK/125)	96 kHz (MCLK/125)	1	0111	0	MCLK

¹ BCLK frequency is for master mode and slave right-justified mode only.

ACTIVE, ADDRESS 0x09

Table 33. Active Register Bit Map

D8	D7	D6	D5	D4	D3	D2	D1	D0
0	0	0	0	0	0	0	0	ACTIVE

Table 34. Descriptions of Active Register Bit

Bit Name	Description	Settings
ACTIVE	Digital core activation control	0 = disable digital core (default) 1 = activate digital core

RESET, ADDRESS 0x0F

Table 35. Software Reset Register Bit Map

D8	D7	D6	D5	D4	D3	D2	D1	D0
RESET [8:0]								

Table 36. Descriptions of Software Reset Register Bits

Bit Name	Description	Settings
RESET [8:0]	Write all 0s to this register to set all registers to their default settings. Other data written to this register has no effect.	0 = reset (default)

ALC CONTROL 1, ADDRESS 0x10

Table 37. ALC Control 1 Register Bit Map

D8	D7	D6	D5	D4	D3	D2	D1	D0
ALCSEL [1:0]		MAXGAIN [2:0]			ALCL [[3:0]			

Table 38. Descriptions of ALC Control 1 Register Bits

Bit Name	Description	Settings
ALCSEL [1:0]	ALC select	00 = ALC disabled (default) 01 = ALC enabled on right channel only 10 = ALC enabled on left channel only 11 = ALC enabled on both channels
MAXGAIN [2:0]	PGA maximum gain	000 = -12 dB 001 = -6 dB ... 6 dB steps up to 111 = 30 dB (default)
ALCL [3:0]	ALC target level	0000 = -28.5 dBFS 0001 = -27 dBFS ... 1011 = -12 dBFS (default) ... 1.5 dB steps up to 1111 = -6 dBFS

ALC CONTROL 2, ADDRESS 0x11

Table 39. ALC Control 2 Register Bit Map

D8	D7	D6	D5	D4	D3	D2	D1	D0
0	DCY [3:0]				ATK [3:0]			

Table 40. Descriptions of ALC Control 2 Register Bits

Bit Name	Description	Settings
DCY [3:0]	Decay (release) time control	0000 = 24 ms 0001 = 48 ms 0010 = 96 ms 0011 = 192 ms (default) ... (Time doubles with every step) 1010 = 24.576 sec
ATK [3:0]	ALC attack time control	0000 = 6 ms 0001 = 12 ms 0010 = 24 ms (default) ... (Time doubles with every step) 1010 = 6.144 sec

NOISE GATE, ADDRESS 0x12**Table 41. Noise Gate Register Bit Map**

D8	D7	D6	D5	D4	D3	D2	D1	D0
0	NGTH [4:0]					NGG [1:0]		NGAT

Table 42. Descriptions of Noise Gate Register Bits

Bit Name	Description	Settings
NGTH [4:0]	Noise gate threshold	00000 = -76.5 dBFS (default) 00001 = -75 dBFS ... 1.5 dB steps up to 11110 = -31.5 dBFS 11111 = -30 dBFS
NGG [1:0]	Noise gate type	X0 = hold PGA gain constant (default) ¹ 01 = mute output 11 = reserved
NGAT	Noise gate control	0 = noise gate disable (default) 1 = noise gate enable

¹ X = don't care.

OUTLINE DIMENSIONS

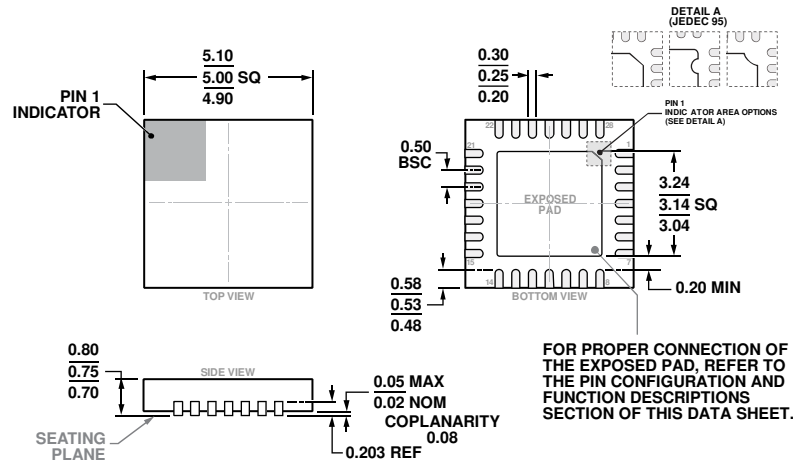

ORDERING GUIDE

Model ¹	Temperature Range	Package Description	Package Option ²
SSM2602CPZ-REEL	-40°C to +85°C	28-Lead Lead Frame Chip Scale Package [LFCSP]	CP-28-10
SSM2602CPZ-REEL7	-40°C to +85°C	28-Lead Lead Frame Chip Scale Package [LFCSP]	CP-28-10

¹ Z = RoHS Compliant Part.

² CP-28-10 package was formerly CP-28-6 package.