

DRAWING MADE IN AMERICAN PROJECTION

NUMBER 60115

REVERSE REEL OF 60115-1  
2.

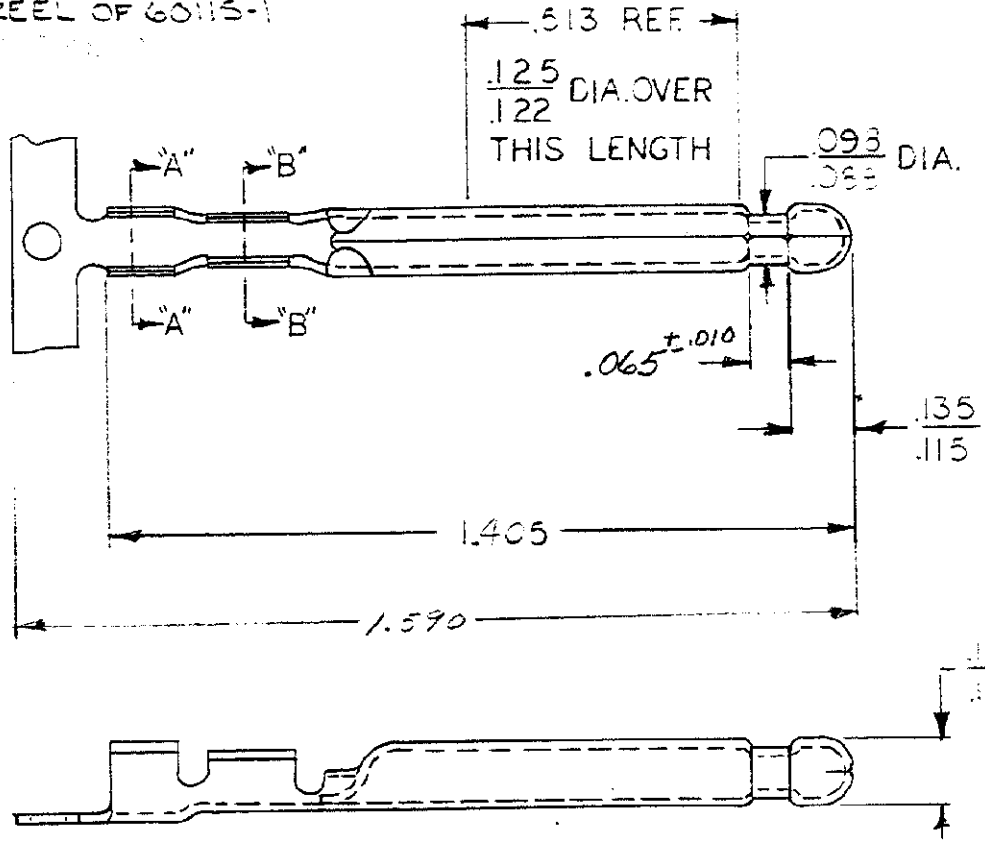

PART	FINISH
60115-1	NONE
<del>60115-2</del>	<del>SILVER</del>
<del>60115-3</del>	<del>PRE-TIN</del>
60115-4 $\Delta$	NONE

DIMENSIONS IN INCHES. DO NOT SCALE PRINT.

K	REV PER AF-6703				3/1/72
J	ADD 60115-4	TTI	2/21/72		2-21-72
H	REV 60115-3	AF	1/23/72		1-23-72
G	OBE 60115-2	A4534	2/1/72		2-28-72
F	REVISED	A4345	2/1/72		10-25-71
E	REVISED	A3094	2/1/72		8-27-71
D	ADD 60115-3	TTI	2/1/72		7-30-71
C	REVISED	A2912	2/1/72		1-22-71
B	REDRAWN	A2058	2/1/72		2/4/72

©1960 BY AMP INCORPORATED, ALL RIGHTS RESERVED. AMP PRODUCTS COVERED BY PATENTS AND/OR PATENTS PENDING.

CUSTOMER COPY REFERENCE ONLY

MATERIAL AND FINISH  
**.016 BRASS**  
**SEE TABLE**



AMP INCORPORATED  
HARRISBURG, PENNA.

WIRE RANGE INSULATION  
22-20 1090-375

CLASS — H —

TYPE — H —

TOLERANCE EXCEPT AS NOTED  
± .015 ± 1°

SCALE — H —

LOG AF **A** NO **60115**

PRINT	DR	DATE	DE	CHK	APP
50	LK ESPENSHADE	2-4-72	AF	KW	
	CHK				

NAME **BLANKET PIN — .125 DIA.**