

THIS DRAWING IS UNPUBLISHED. RELEASED FOR PUBLICATION
 © COPYRIGHT - By - ALL RIGHTS RESERVED.

LOC		DIST		REVISIONS			
P	LTR	DESCRIPTION		DATE	DWN	APVD	
	G	REV PER ECO 14-017026		11-11-14	CT	DE	

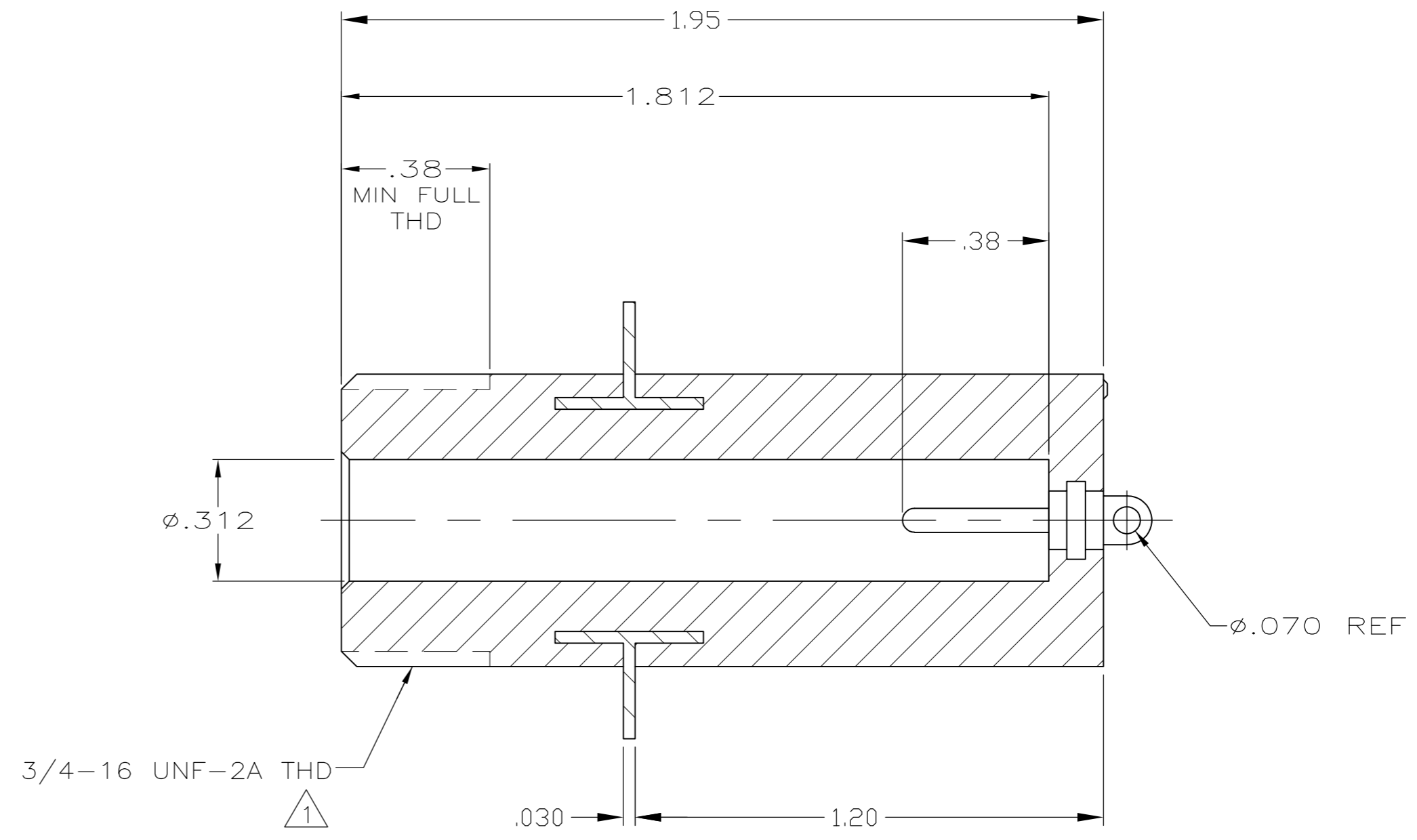
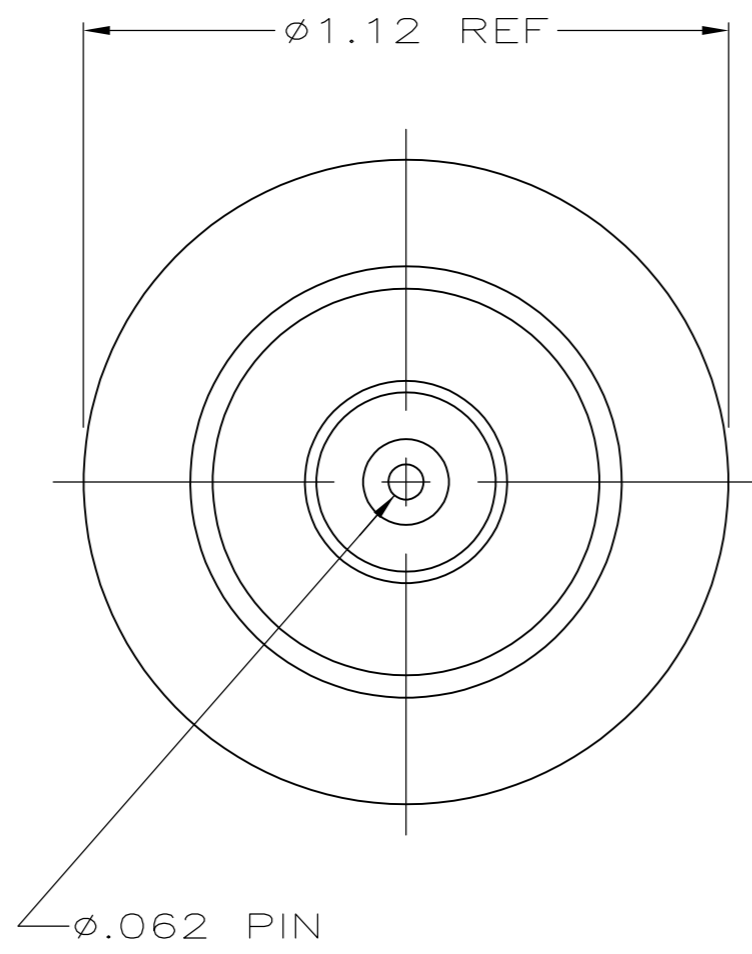

- 1. SCREW THREAD MEASUREMENT IN ACCORDANCE WITH H28 HANDBOOK (3 WIRE METHOD) USING WIRE .03608 DIA MEASUREMENT OVER WIRE SHALL BE .7654/.7474
- 2. THIS RECEPTACLE IS HERMETICALLY SEALED.
- 3. MARKED PER MIL-STD-130.

TIN PLATED	5-861257-1
TIN-LEAD PLATED	861257-1
PIN & FLANGE FINISH	PART NO.

THIS DRAWING IS A CONTROLLED DOCUMENT.		DWN	C.C.THOMAS	7-14-06	TE Connectivity FLANGED RECEPTACLE,LGH-3																	
DIMENSIONS: INCHES		CHK	D.EABY	7-14-06																		
TOLERANCES UNLESS OTHERWISE SPECIFIED:		APVD	D.EABY	7-14-06																		
<table border="1"> <tr><td>0 PLC</td><td>±</td><td>-</td></tr> <tr><td>1 PLC</td><td>±</td><td>-</td></tr> <tr><td>2 PLC</td><td>±</td><td>.01</td></tr> <tr><td>3 PLC</td><td>±</td><td>.005</td></tr> <tr><td>4 PLC</td><td>±</td><td>-</td></tr> <tr><td>ANGLES</td><td>±</td><td>1°</td></tr> </table>		0 PLC	±	-		1 PLC	±	-	2 PLC	±	.01	3 PLC	±	.005	4 PLC	±	-	ANGLES	±	1°	PRODUCT SPEC	-
0 PLC	±	-																				
1 PLC	±	-																				
2 PLC	±	.01																				
3 PLC	±	.005																				
4 PLC	±	-																				
ANGLES	±	1°																				
MATERIAL	MOLDED GLASS EPOXY	FINISH	SEE TABLE	WEIGHT	-																	
CUSTOMER DRAWING		SCALE	3:1	SHEET	1 of 1																	
SIZE		CAGE CODE	A2 00779	DRAWING NO	C=861257																	
RESTRICTED TO		-																				
REV		G																				

861257