

LOC	DIST	REV	ZONE	LTR	DESCRIPTION	DATE	APPD
CM	53	P			REDWN AND REV PER ECN CM-2599	12-6-89	KU
		V					RS

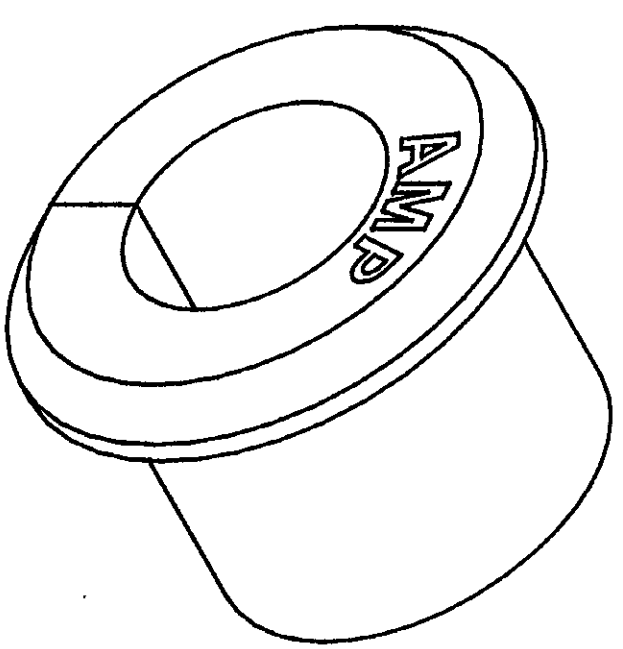
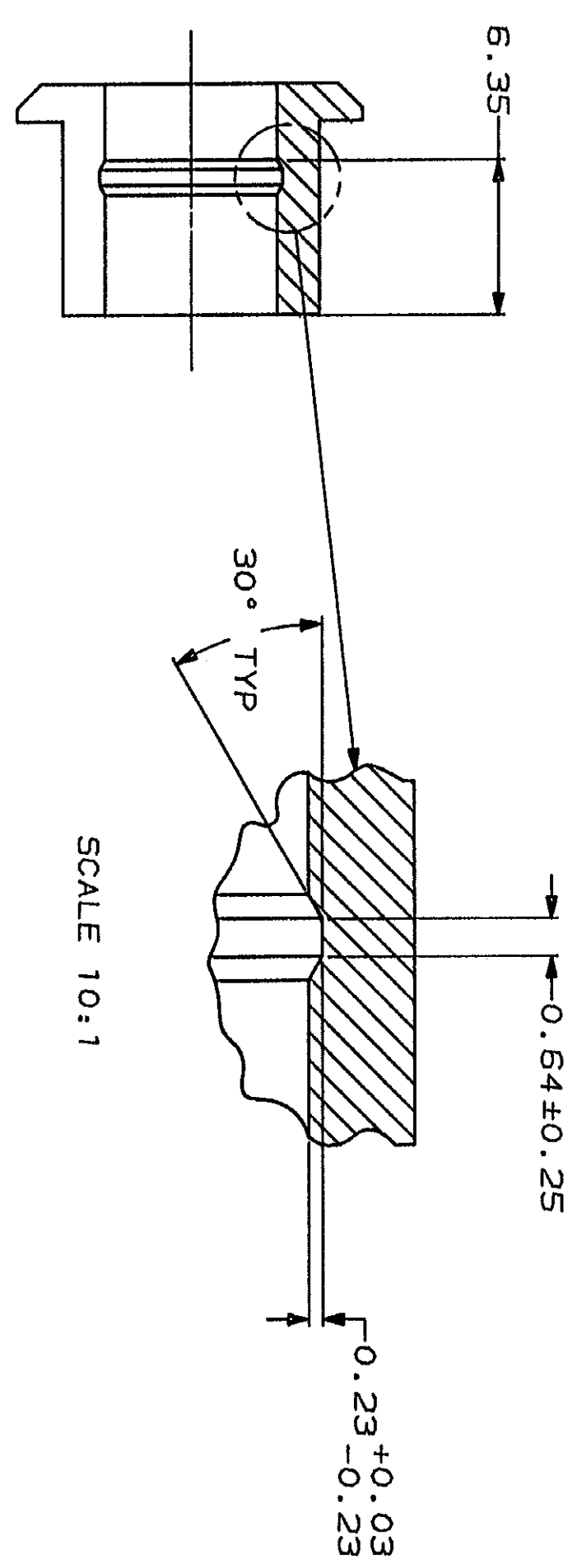
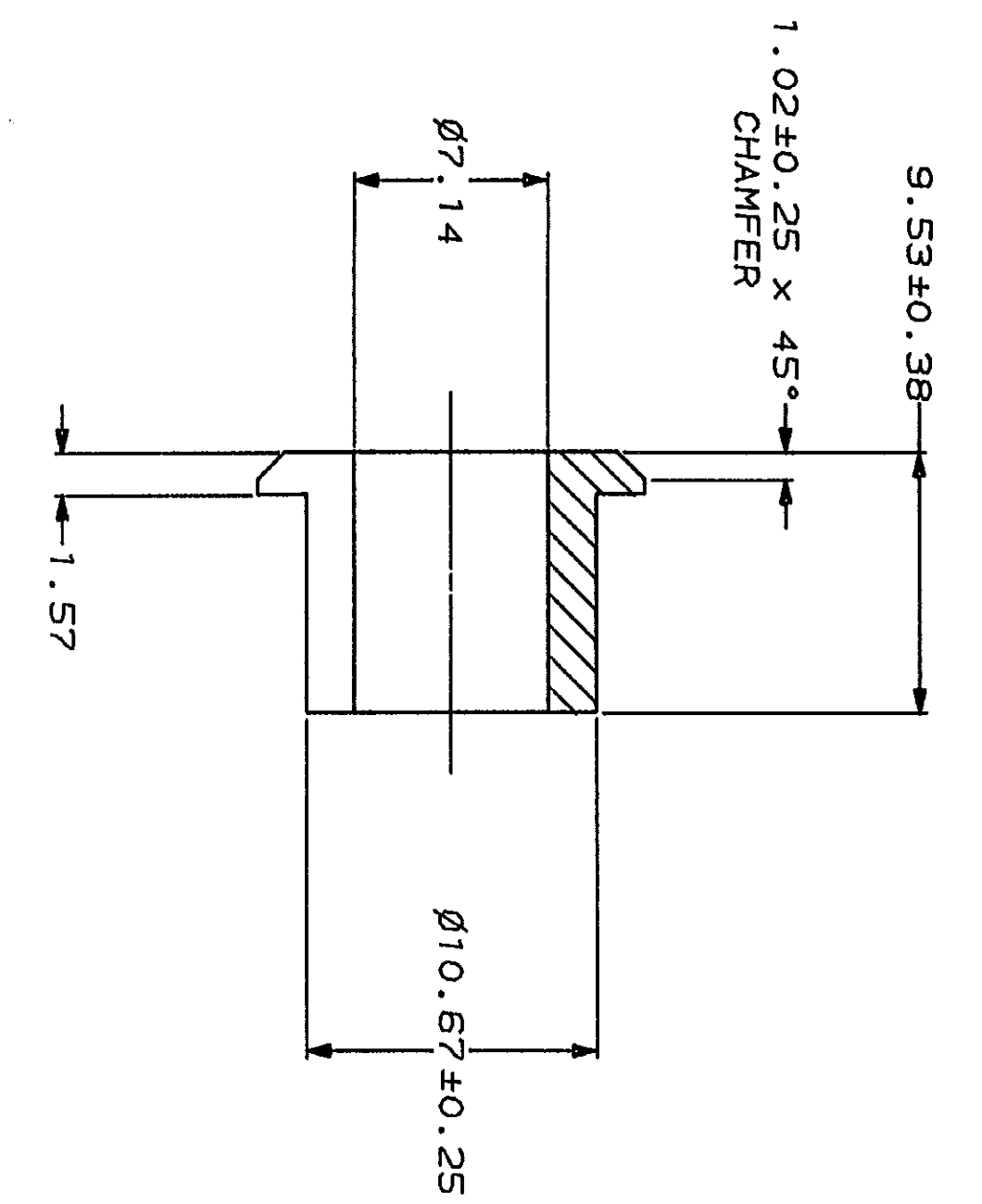
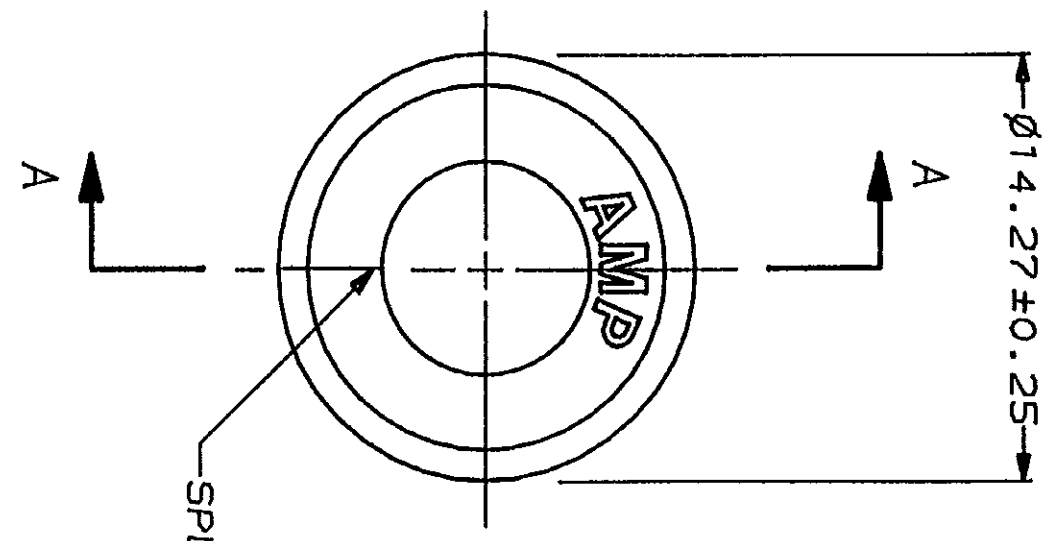

3-DIMENSIONAL MODEL  
NTS

MM	IN	MM	IN	MM	IN
0.38	.015	7.14	.281	-	-
0.25	.010	6.35	.250	-	-
0.23	.009	1.57	.062	14.27	.562
0.13	.005	1.02	.040	10.67	.420
0.03	.001	0.64	.025	9.53	.375

CONVERSION TABLE

1. USE WITH STRAIN RELIEF 350374.  
 ▲ MOLDING COMPOUND PVC, FLEXIBLE, 55/75 DUREOMETER (B SCALE), BLACK.

SECTION A-A  
OPTIONAL CONSTRUCTION

**METRIC**

DO NOT SCALE PRINT.  
 UNLESS SPECIFIED DIMENSIONS IN MM (INCHES) TOLERANCES ON:  
 2 PLC DEC ± 0.13  
 3 PLC DEC ± 1.0°  
 ANGLES  
 MATERIAL

DR: *[Signature]* 12-7-89  
 CHK: *[Signature]* 12-8-89  
 APPD: *[Signature]* 12-11-89  
 NAME: GROMMET, SPLIT, M.R.  
 AMP INCORPORATED  
 Harrisburg, Pa. 17105

FINISH	-	APPLICATION SPEC	SCALE	C	CAGE CODE	00779	DRAWING NO	350380
WEIGHT	-	PRODUCT SPEC	SCALE	4:1	SHEET	1 OF 1	PART NO 1-350380-1	