



# 74F240, 74F244

## Octal Buffers/Line Drivers with 3-STATE Outputs

### Features

- 3-STATE outputs drive bus lines or buffer memory address registers
- Outputs sink 64mA (48mA mil)
- 12mA source current
- Input clamp diodes limit high-speed termination effects

### General Description

The 74F240 and 74F244 are octal buffers and line drivers designed to be employed as memory and address drivers, clock drivers and bus-oriented transmitters/receivers which provide improved PC and board density.

### Ordering Information

Order Code	Package Number	Package Description
74F240SC <sup>(1)</sup>	M20B	20-Lead Small Outline Integrated Circuit (SOIC), JEDEC MS-013, 0.300" Wide
74F240SJ <sup>(1)</sup>	M20D	20-Lead Small Outline Package (SOP), EIAJ TYPE II, 5.3mm Wide
74F240PC	N20A	20-Lead Plastic Dual-In-Line Package (PDIP), JEDEC MS-001, 0.300" Wide
74F244SC <sup>(1)</sup>	M20B	20-Lead Small Outline Integrated Circuit (SOIC), JEDEC MS-013, 0.300" Wide
74F244SJ <sup>(1)</sup>	M20D	20-Lead Small Outline Package (SOP), EIAJ TYPE II, 5.3mm Wide
74F244MSA <sup>(1)</sup>	MSA20	20-Lead Shrink Small Outline Package (SSOP), JEDEC MO-150, 5.3mm Wide
74F244PC	N20A	20-Lead Plastic Dual-In-Line Package (PDIP), JEDEC MS-001, 0.300" Wide

#### Note:

1. Devices also available in Tape and Reel. Specify by appending the suffix letter "X" to the ordering number.

### Connection Diagrams

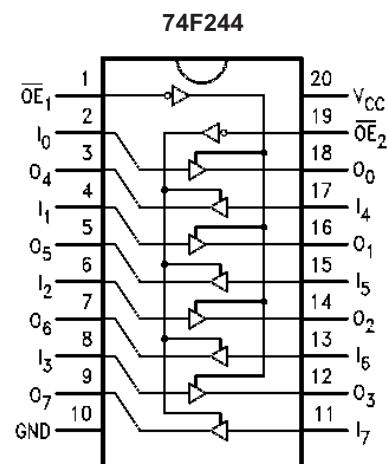
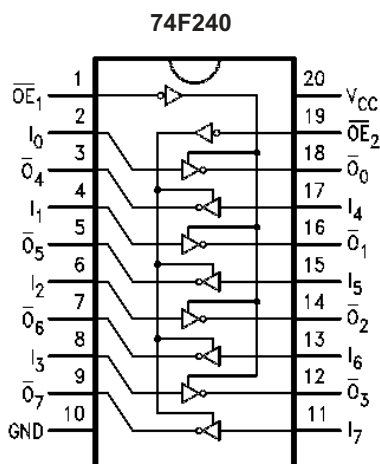

## Logic Symbols

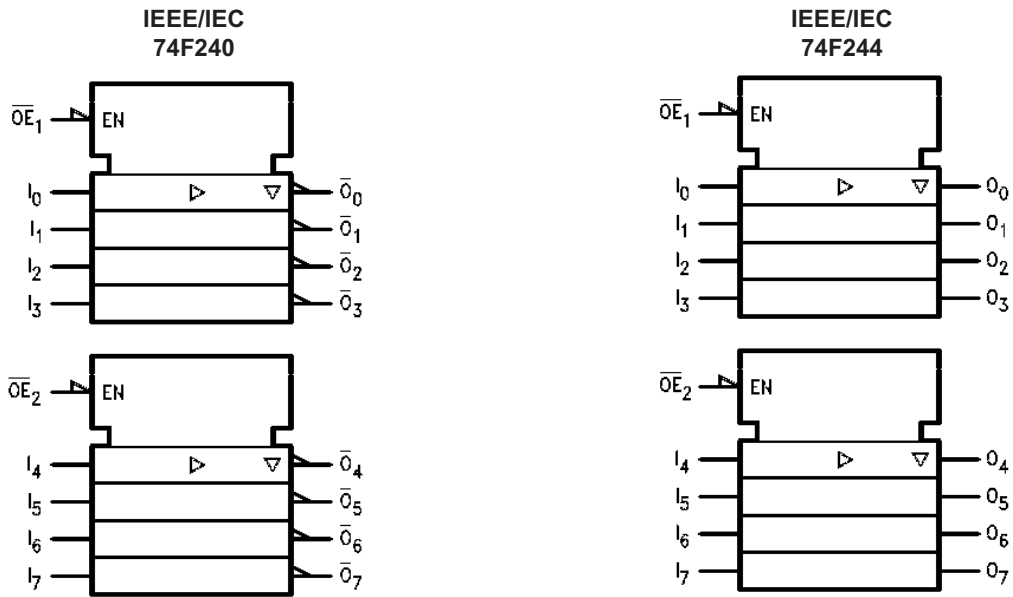

## Unit Loading/Fan Out

Pin Names	Description	U.L. HIGH/LOW	Input $I_{IH} / I_{IL}$ , Output $I_{OH} / I_{OL}$
$\overline{OE}_1, \overline{OE}_2$	3-STATE Output Enable Input (Active LOW)	1.0 / 1.667	20 $\mu$ A / -1mA
$OE_2$	3-STATE Output Enable Input (Active HIGH)	1.0 / 1.667	20 $\mu$ A / -1mA
$I_0-I_7$	Inputs (74F240)	1.0 / 1.667 <sup>(2)</sup>	20 $\mu$ A / -1mA
$I_0-I_7$	Inputs (74F244)	1.0 / 2.667 <sup>(2)</sup>	20 $\mu$ A / -1.6mA
$\overline{O}_0-\overline{O}_7, O_0-O_7$	Outputs	600 / 106.6 (80)	-12mA / 64mA (48mA)

### Note:

2. Worst-case 74F240 enabled; 74F244 disabled.

## Truth Tables

### 74F240

$\overline{OE}_1$	$D_{1n}$	$O_{1n}$	$\overline{OE}_2$	$D_{2n}$	$O_{2n}$
H	X	Z	H	X	Z
L	H	L	L	H	L
L	L	H	L	L	H

### 74F244

$\overline{OE}_1$	$D_{1n}$	$O_{1n}$	$\overline{OE}_2$	$D_{2n}$	$O_{2n}$
H	X	Z	H	X	Z
L	H	H	L	H	H
L	L	L	L	L	L

H = HIGH Voltage Level

L = LOW Voltage Level

X = Immaterial

Z = High Impedance

## Absolute Maximum Ratings

Stresses exceeding the absolute maximum ratings may damage the device. The device may not function or be operable above the recommended operating conditions and stressing the parts to these levels is not recommended. In addition, extended exposure to stresses above the recommended operating conditions may affect device reliability. The absolute maximum ratings are stress ratings only.

Symbol	Parameter	Rating
$T_{STG}$	Storage Temperature	-65°C to +150°C
$T_A$	Ambient Temperature Under Bias	-55°C to +125°C
$T_J$	Junction Temperature Under Bias	-55°C to +150°C
$V_{CC}$	$V_{CC}$ Pin Potential to Ground Pin	-0.5V to +7.0V
$V_{IN}$	Input Voltage <sup>(3)</sup>	-0.5V to +7.0V
$I_{IN}$	Input Current <sup>(3)</sup>	-30mA to +5.0mA
$V_O$	Voltage Applied to Output in HIGH State (with $V_{CC} = 0V$ )	
	Standard Output	-0.5V to $V_{CC}$
	3-STATE Output	-0.5V to 5.5V
	Current Applied to Output in LOW State (Max.)	twice the rated $I_{OL}$ (mA)
	ESD Last Passing Voltage (Min.)	4000V

**Note:**

3. Either voltage limit or current limit is sufficient to protect inputs.

## Recommended Operating Conditions

The Recommended Operating Conditions table defines the conditions for actual device operation. Recommended operating conditions are specified to ensure optimal performance to the datasheet specifications. Fairchild does not recommend exceeding them or designing to absolute maximum ratings.

Symbol	Parameter	Rating
$T_A$	Free Air Ambient Temperature	0°C to +70°C
$V_{CC}$	Supply Voltage	+4.5V to +5.5V

## DC Electrical Characteristics

Symbol	Parameter	$V_{CC}$	Conditions	Min.	Typ.	Max.	Units
$V_{IH}$	Input HIGH Voltage		Recognized as a HIGH Signal	2.0			V
$V_{IL}$	Input LOW Voltage		Recognized as a LOW Signal			0.8	V
$V_{CD}$	Input Clamp Diode Voltage	Min.	$I_{IN} = -18\text{mA}$			-1.2	V
$V_{OH}$	Output HIGH Voltage	10% $V_{CC}$	Min. $I_{OH} = -3\text{mA}$	2.4			V
		10% $V_{CC}$		$I_{OH} = -15\text{mA}$	2.0		
		5% $V_{CC}$		$I_{OH} = -3\text{mA}$	2.7		
$V_{OL}$	Output LOW Voltage	10% $V_{CC}$	Min. $I_{OL} = 64\text{mA}$			0.55	V
$I_{IH}$	Input HIGH Current	Max.	$V_{IN} = 2.7\text{V}$			5.0	$\mu\text{A}$
$I_{BVI}$	Input HIGH Current Breakdown Test	Max.	$V_{IN} = 7.0\text{V}$			7.0	$\mu\text{A}$
$I_{CEX}$	Output HIGH Leakage Current	Max.	$V_{OUT} = V_{CC}$			50	$\mu\text{A}$
$V_{ID}$	Input Leakage Test	0.0	$I_{ID} = 1.9\mu\text{A}$	4.75			V
			All Other Pins Grounded				
$I_{OD}$	Output Leakage Circuit Current	0.0	$V_{IOD} = 150\text{mV}$			3.75	$\mu\text{A}$
			All Other Pins Grounded				
$I_{IL}$	Input LOW Current	Max.	$V_{IN} = 0.5\text{V}$ ( $\overline{OE}_1, \overline{OE}_2, OE_2, D_n$ (74F240))			-1.0	mA
			$V_{IN} = 0.5\text{V}$ ( $D_n$ (74F244))			-1.6	
$I_{OZH}$	Output Leakage Current	Max.	$V_{OUT} = 2.7\text{V}$			50	$\mu\text{A}$
$I_{OZL}$	Output Leakage Current	Max.	$V_{OUT} = 0.5\text{V}$			-50	$\mu\text{A}$
$I_{OS}$	Output Short-Circuit Current	Max.	$V_{OUT} = 0\text{V}$	-100		-225	mA
$I_{ZZ}$	Bus Drainage Test	0.0V	$V_{OUT} = 5.25\text{V}$			500	$\mu\text{A}$
$I_{CCH}$	Power Supply Current (74F240)	Max.	$V_O = \text{HIGH}$		19	29	mA
$I_{CCL}$	Power Supply Current (74F240)	Max.	$V_O = \text{LOW}$		50	75	mA
$I_{CCZ}$	Power Supply Current (74F240)	Max.	$V_O = \text{HIGH Z}$		42	63	mA
$I_{CCH}$	Power Supply Current (74F244)	Max.	$V_O = \text{HIGH}$		40	60	mA
$I_{CCL}$	Power Supply Current (74F244)	Max.	$V_O = \text{LOW}$		60	90	mA
$I_{CCZ}$	Power Supply Current (74F244)	Max.	$V_O = \text{HIGH Z}$		60	90	mA

## AC Electrical Characteristics

Symbol	Parameter	$T_A = +25^\circ\text{C}$ , $V_{CC} = +5.0\text{V}$ , $C_L = 50\text{pF}$			$T_A = -55^\circ\text{C to } +125^\circ\text{C}$ , $V_{CC} = 5.0\text{V}$ , $C_L = 50\text{pF}$		$T_A = 0^\circ\text{C to } +70^\circ\text{C}$ , $V_{CC} = 5.0\text{V}$ , $C_L = 50\text{pF}$		Units
		Min.	Typ.	Max.	Min.	Max.	Min.	Max.	
$t_{PLH}$ , $t_{PHL}$	Propagation Delay Data to Output (74F240)	3.0	5.1	7.0	3.0	9.0	3.0	8.0	ns
		2.0	3.5	4.7	2.0	6.0	2.0	5.7	
$t_{PZH}$ , $t_{PZL}$	Output Enable Time (74F240)	2.0	3.5	4.7	2.0	6.5	2.0	5.7	ns
		4.0	6.9	9.0	4.0	10.5	4.0	10.0	
$t_{PHZ}$ , $t_{PLZ}$	Output Disable Time (74F240)	2.0	4.0	5.3	2.0	6.5	2.0	6.3	ns
		2.0	6.0	8.0	2.0	12.5	2.0	9.5	
$t_{PLH}$ , $t_{PHL}$	Propagation Delay, Data to Output (74F244)	2.5	4.0	5.2	2.0	6.5	2.5	6.2	ns
		2.5	4.0	5.2	2.0	7.0	2.5	6.5	
$t_{PZH}$ , $t_{PZL}$	Output Enable Time (74F244)	2.0	4.3	5.7	2.0	7.0	2.0	6.7	ns
		2.0	5.4	7.0	2.0	8.5	2.0	8.0	
$t_{PHZ}$ , $t_{PLZ}$	Output Disable Time (74F244)	2.0	4.5	6.0	2.0	7.0	2.0	7.0	ns
		2.0	4.5	6.0	2.0	7.5	2.0	7.0	

## Physical Dimensions

Dimensions are in inches (millimeters) unless otherwise noted.

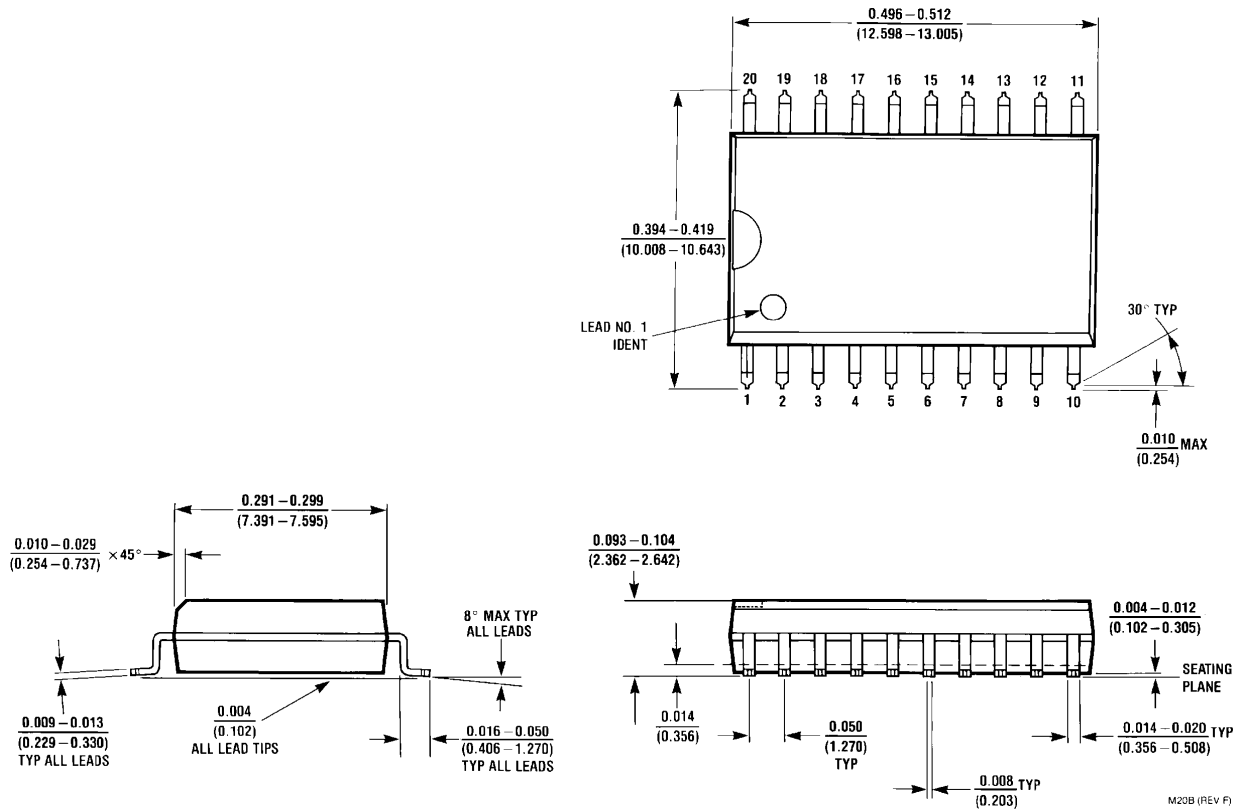

Figure 1. 20-Lead Small Outline Integrated Circuit (SOIC), JEDEC MS-013, 0.300" Wide Package Number M20B

### Physical Dimensions (Continued)

Dimensions are in millimeters unless otherwise noted.

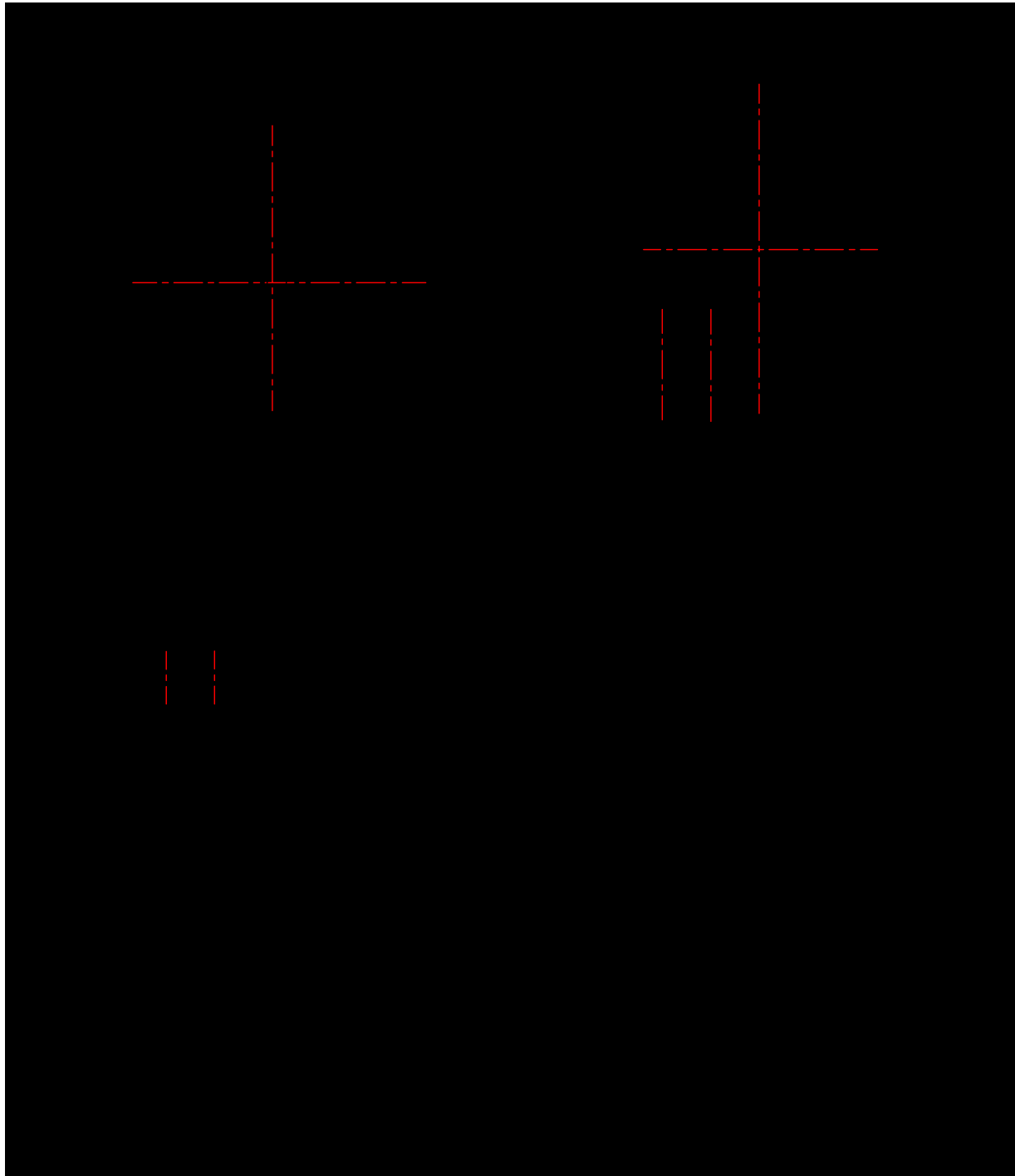
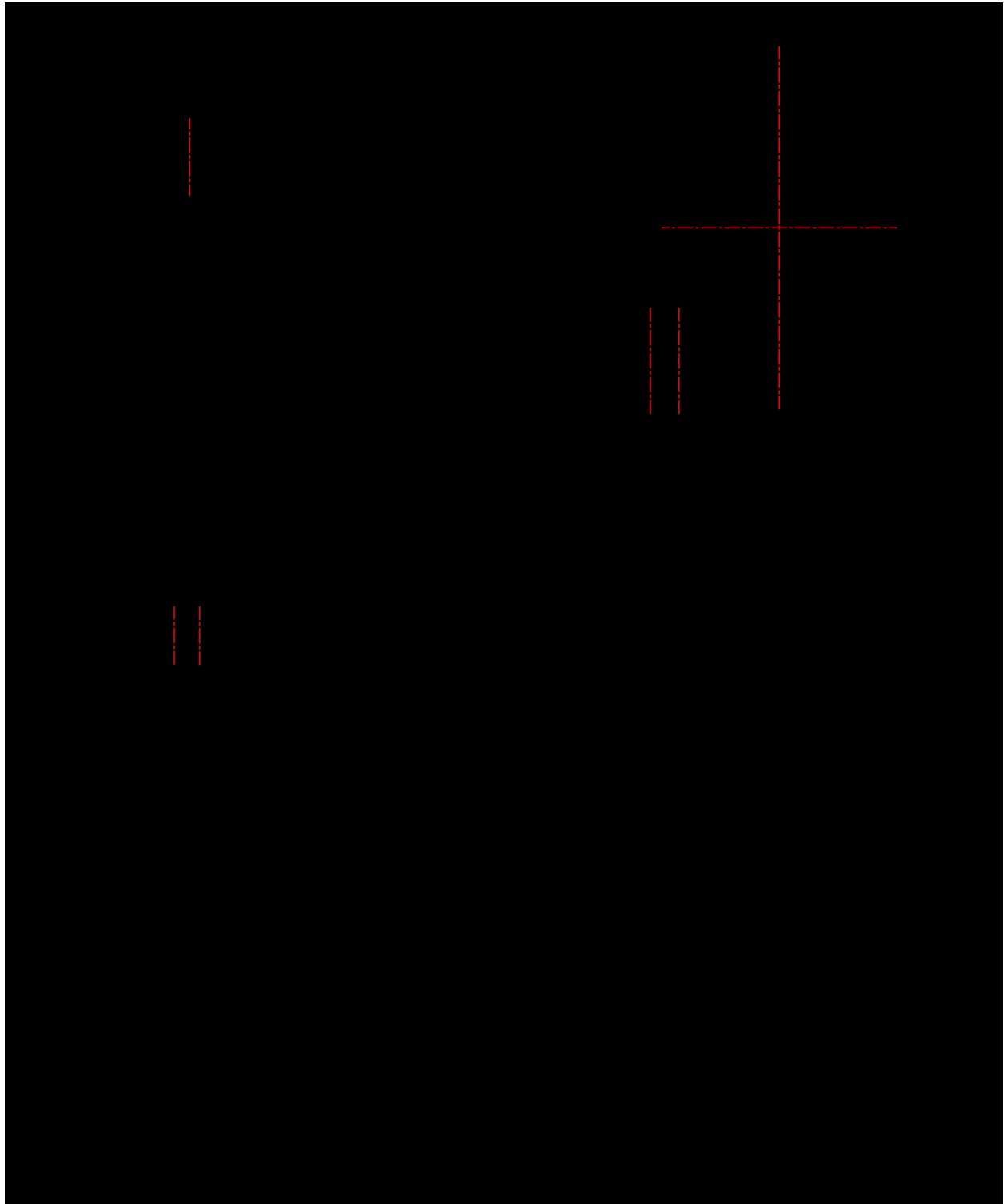

Figure 2. 20-Lead Small Outline Package (SOP), EIAJ TYPE II, 5.3mm Wide  
Package Number M20D

**Physical Dimensions** (Continued)

Dimensions are in millimeters unless otherwise noted.

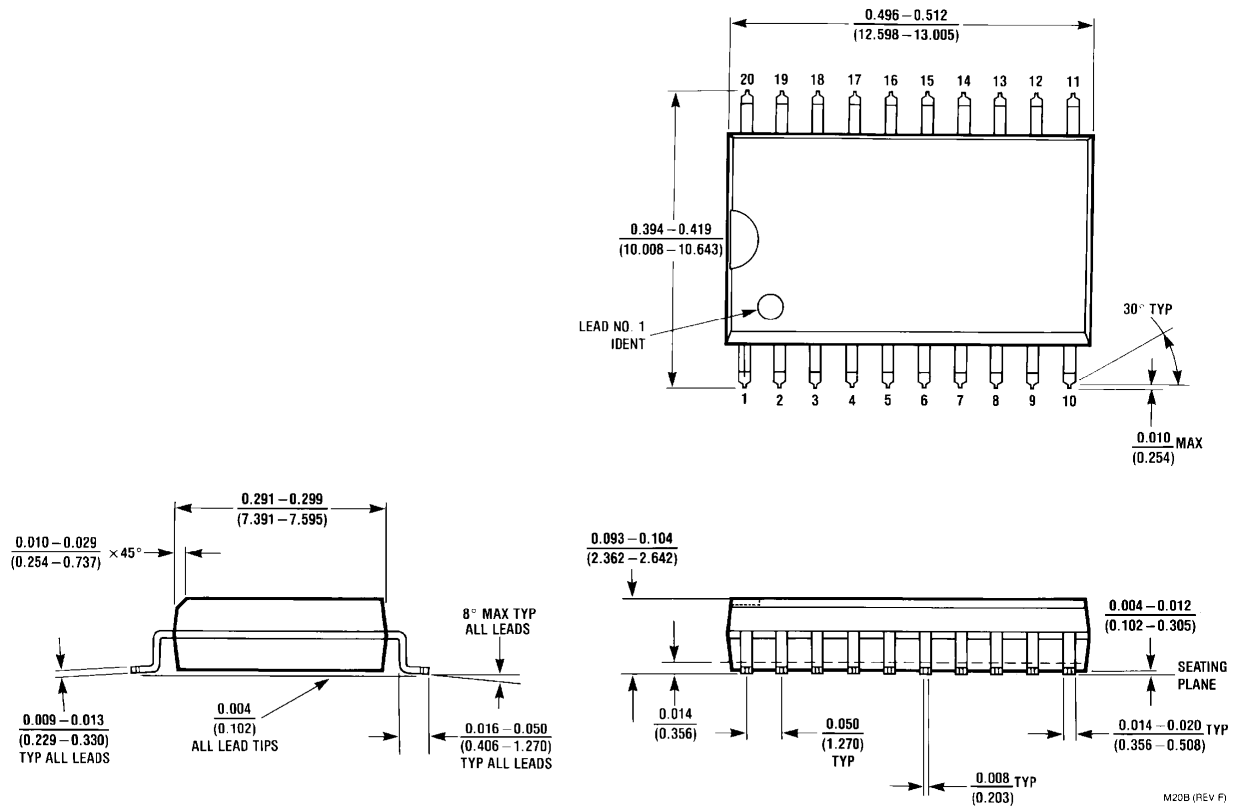

**Figure 3. 20-Lead Shrink Small Outline Package (SSOP), JEDEC MO-150, 5.3mm Wide  
Package Number MSA20**



**Physical Dimensions** (Continued)

Dimensions are in inches (millimeters) unless otherwise noted.



**Figure 4. 20-Lead Plastic Dual-In-Line Package (PDIP), JEDEC MS-001, 0.300" Wide Package Number N20A**



15