



Is Now Part of



**ON Semiconductor®**

To learn more about ON Semiconductor, please visit our website at  
[www.onsemi.com](http://www.onsemi.com)

Please note: As part of the Fairchild Semiconductor integration, some of the Fairchild orderable part numbers will need to change in order to meet ON Semiconductor's system requirements. Since the ON Semiconductor product management systems do not have the ability to manage part nomenclature that utilizes an underscore (\_), the underscore (\_) in the Fairchild part numbers will be changed to a dash (-). This document may contain device numbers with an underscore (\_). Please check the ON Semiconductor website to verify the updated device numbers. The most current and up-to-date ordering information can be found at [www.onsemi.com](http://www.onsemi.com). Please email any questions regarding the system integration to [Fairchild\\_questions@onsemi.com](mailto:Fairchild_questions@onsemi.com).

ON Semiconductor and the ON Semiconductor logo are trademarks of Semiconductor Components Industries, LLC dba ON Semiconductor or its subsidiaries in the United States and/or other countries. ON Semiconductor owns the rights to a number of patents, trademarks, copyrights, trade secrets, and other intellectual property. A listing of ON Semiconductor's product/patent coverage may be accessed at [www.onsemi.com/site/pdf/Patent-Marking.pdf](http://www.onsemi.com/site/pdf/Patent-Marking.pdf). ON Semiconductor reserves the right to make changes without further notice to any products herein. ON Semiconductor makes no warranty, representation or guarantee regarding the suitability of its products for any particular purpose, nor does ON Semiconductor assume any liability arising out of the application or use of any product or circuit, and specifically disclaims any and all liability, including without limitation special, consequential or incidental damages. Buyer is responsible for its products and applications using ON Semiconductor products, including compliance with all laws, regulations and safety requirements or standards, regardless of any support or applications information provided by ON Semiconductor. "Typical" parameters which may be provided in ON Semiconductor data sheets and/or specifications can and do vary in different applications and actual performance may vary over time. All operating parameters, including "Typicals" must be validated for each customer application by customer's technical experts. ON Semiconductor does not convey any license under its patent rights nor the rights of others. ON Semiconductor products are not designed, intended, or authorized for use as a critical component in life support systems or any FDA Class 3 medical devices or medical devices with a same or similar classification in a foreign jurisdiction or any devices intended for implantation in the human body. Should Buyer purchase or use ON Semiconductor products for any such unintended or unauthorized application, Buyer shall indemnify and hold ON Semiconductor and its officers, employees, subsidiaries, affiliates, and distributors harmless against all claims, costs, damages, and expenses, and reasonable attorney fees arising out of, directly or indirectly, any claim of personal injury or death associated with such unintended or unauthorized use, even if such claim alleges that ON Semiconductor was negligent regarding the design or manufacture of the part. ON Semiconductor is an Equal Opportunity/Affirmative Action Employer. This literature is subject to all applicable copyright laws and is not for resale in any manner.



# FSA3000 — Two-Port, High-Speed, MHL™ Switch

## Features

- Low On Capacitance: 2.7 pF/4.1 pF MHL/USB (Typical)
- Low Power Consumption: 30  $\mu$ A Maximum
- MHL Data Rate: 4.92 Gbps ( $f_{3dB} = 2.46$  GHz)
- Packaged in 10-Lead MicroPak™
- Over-Voltage Tolerance (OVT) on all USB and MHL Ports; Up to 5.25 V without External Components

## Applications

- Cell Phones and Digital Cameras

## Description

The FSA3000 is a bi-directional, low-power, two-port, high-speed, USB2.0 and video data switch that supports the Mobile High-Definition Link (MHL) Specification Rev. 2.0. Configured as a double-pole, double-throw (DPDT) switch for data, FSA3000 is optimized for USB2.0 and MHL data sources.

The FSA3000 contains circuitry on the switch I/O pins that allows the device to withstand an over-voltage condition in applications where the  $V_{CC}$  supply is powered off ( $V_{CC}=0$ ). The FSA3000 minimizes current consumption even when the voltage applied to the control pins is lower than the supply voltage ( $V_{CC}$ ). This feature is especially valuable in mobile applications, such as cell phones; allowing direct interface with the general-purpose I/Os of the baseband processor. Other applications include switching and connector sharing in portable cell phones, digital cameras, and notebook computers.

## Ordering Information

Part Number	Top Mark	Operating Temperature Range	Package
FSA3000L10X	LK	-40 to +85°C	10-Lead, MicroPak™ 1.6 x 2.1 mm JEDEC MO255B
FSA3000L10X_F131	LK		10-Lead, MicroPak™ 1.6 x 2.1 mm JEDEC MO255B, Package Rotated 90° in Tape and Reel

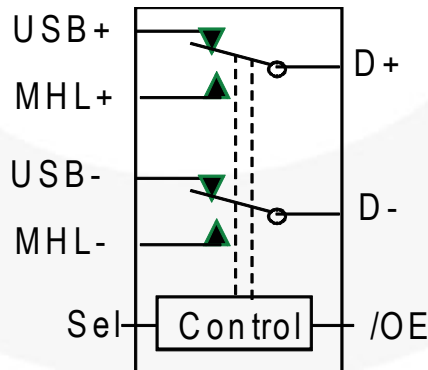

Figure 1. Analog Symbol

All trademarks are the property of their respective owners.

### Data Switch Select Truth Table

SEL <sup>(1)</sup>	/OE <sup>(1)</sup>	Function
X	HIGH	USB and MHL paths both high impedance
LOW	LOW	D+/D- connected to USB+/USB-
HIGH	LOW	D+/D- connected to MHL+/MHL-

**Note:**

- Control inputs should never be left floating or unconnected.

### Pin Configurations

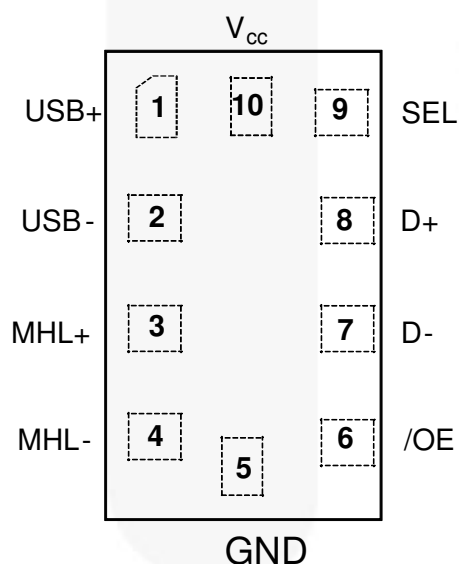

Figure 2. Pin Assignments (Top-Through View)

### Pin Definitions

Pin#	Name	Description
1	USB+	USB Differential Data (Positive)
2	USB-	USB Differential Data (Negative)
3	MHL+	MHL Differential Data (Positive)
4	MHL-	MHL Differential Data (Negative)
5	GND	Ground
6	/OE	Output Enable (Active LOW)
7	D-	Data Switch Output (Negative)
8	D+	Data Switch Output (Positive)
9	SEL	Data Switch Select
10	V <sub>CC</sub>	Supply

## Absolute Maximum Ratings

Stresses exceeding the absolute maximum ratings may damage the device. The device may not function or be operable above the recommended operating conditions and stressing the parts to these levels is not recommended. In addition, extended exposure to stresses above the recommended operating conditions may affect device reliability. The absolute maximum ratings are stress ratings only.

Symbol	Parameter		Min.	Max.	Unit
V <sub>CC</sub>	Supply Voltage		-0.5	5.5	V
V <sub>CNTRL</sub>	DC Input Voltage (SEL, /OE) <sup>(2)</sup>		-0.5	V <sub>CC</sub>	V
V <sub>SW</sub>	DC Switch I/O Voltage <sup>(2,3)</sup>		-0.50	5.25	V
I <sub>IK</sub>	DC Input Diode Current		-50		mA
I <sub>OUT</sub>	DC Output Current			100	mA
T <sub>STG</sub>	Storage Temperature		-65	+150	°C
MSL	Moisture Sensitivity Level (JEDEC J-STD-020A)			1	
ESD	Human Body Model, JEDEC: JESD22-A114	All Pins		3.5	kV
	IEC 61000-4-2, Level 4, for D+/D- and V <sub>CC</sub> Pins <sup>(4)</sup>	Contact		8	
	IEC 61000-4-2, Level 4, for D+/D- and V <sub>CC</sub> Pins <sup>(4)</sup>	Air		15	
	Charged Device Model, JESD22-C101			2	

### Notes:

- The input and output negative ratings may be exceeded if the input and output diode current ratings are observed.
- V<sub>SW</sub> refers to analog data switch paths (USB and MHL).
- Testing performed in a system environment using TVS diodes.

## Recommended Operating Conditions

The Recommended Operating Conditions table defines the conditions for actual device operation. Recommended operating conditions are specified to ensure optimal performance to the datasheet specifications. Fairchild does not recommend exceeding them or designing to Absolute Maximum Ratings.

Symbol	Parameter	Min.	Max.	Unit
V <sub>CC</sub>	Supply Voltage	2.7	4.3	V
t <sub>RAMP(VCC)</sub>	Power Supply Slew Rate	100	1000	μs/V
V <sub>CNTRL</sub>	Control Input Voltage (SEL, /OE) <sup>(5)</sup>	0	4.3	V
θ <sub>JA</sub>	Thermal Resistance		313	C°/W
V <sub>SW(USB)</sub>	Switch I/O Voltage (USB Switch Path)	-0.5	3.6	V
V <sub>SW(MHL)</sub>	Switch I/O Voltage (MHL Switch Path)	1.65	3.45	V
T <sub>A</sub>	Operating Temperature	-40	+85	°C

### Note:

- The control inputs must be held HIGH or LOW; they must not float.

## DC Electrical Characteristics

All typical value are at  $T_A=25^\circ\text{C}$  unless otherwise specified.

Symbol	Parameter	Condition	$V_{CC}$ (V)	$T_A = -40^\circ\text{C}$ to $+85^\circ\text{C}$			Unit
				Min.	Typ.	Max.	
$V_{IK}$	Clamp Diode Voltage	$I_{IN} = -18\text{ mA}$	2.7			-1.2	V
$V_{IH}$	Control Input Voltage High	SEL, /OE	2.7 to 4.3	1.25			V
$V_{IL}$	Control Input Voltage Low	SEL, /OE	2.7 to 4.3			0.6	V
$I_{IN}$	Control Input Leakage	$V_{SW}=0$ to 3.6 V, $V_{CNTRL}=0$ to $V_{CC}$	4.3	-500		500	nA
$I_{OZ(MHL)}$	Off-State Leakage for Open MHLn Data Paths	$V_{SW}=1.65 \leq \text{MHL} \leq 3.45\text{ V}$	4.3	-500		500	nA
$I_{OZ(USB)}$	Off-State Leakage for Open USBn Data Paths	$V_{SW}=0 \leq \text{USB} \leq 3.6\text{ V}$	4.3	-500		500	nA
$I_{CL(MHL)}$	On-State Leakage for Closed MHLn Data Paths <sup>(6)</sup>	$V_{SW}=1.65 \leq \text{MHL} \leq 3.45\text{ V}$	4.3	-500		500	nA
$I_{CL(USB)}$	On-State Leakage for Closed USBn Data Paths <sup>(6)</sup>	$V_{SW}=0 \leq \text{USB} \leq 3.6\text{ V}$	4.3	-500		500	nA
$I_{OFF}$	Power-Off Leakage Current (All I/O Ports)	$V_{SW}=0\text{ V}$ or 3.6 V, Figure 4	0	-500		500	nA
$R_{ON(USB)}$	HS Switch On Resistance (USB to Dn Path)	$V_{SW}=0.4\text{ V}$ , $I_{ON}=-8\text{ mA}$ , Figure 3	2.7		3.5	4.8	$\Omega$
$R_{ON(MHL)}$	HS Switch On Resistance (MHL to Dn Path)	$V_{SW}=V_{CC}-1050\text{ mV}$ , $I_{ON}=-8\text{ mA}$ , Figure 3	2.7		4.7	6.0	$\Omega$
$\Delta R_{ON(MHL)}$	Difference in $R_{ON}$ Between MHL Positive-Negative	$V_{SW}=V_{CC}-1050\text{ mV}$ , $I_{ON}=-8\text{ mA}$ , Figure 3,	2.7		0.03		$\Omega$
$\Delta R_{ON(USB)}$	Difference in $R_{ON}$ Between USB Positive-Negative	$V_{SW}=0.4\text{ V}$ , $I_{ON}=-8\text{ mA}$ , Figure 3	2.7		0.18		$\Omega$
$R_{ONF(MHL)}$	Flatness for $R_{ON}$ MHL Path	$V_{SW}=1.65$ to 3.45 V, $I_{ON}=-8\text{ mA}$ , Figure 3	2.7		0.9		$\Omega$
$I_{CC}$	Quiescent Supply Current	$V_{/OE}=0$ , $V_{SEL}=0$ or $V_{CC}$ , $I_{OUT}=0$	4.3			30	$\mu\text{A}$
$I_{CCZ}$	Quiescent Supply Current (High Impedance)	$V_{SEL}=X$ , $V_{/OE}=V_{CC}$ , $I_{OUT}=0$	4.3			1	$\mu\text{A}$
$I_{CCT}$	Increase in Quiescent Supply Current	$V_{SEL}=X$ , $V_{/OE}=1.65\text{ V}$	4.3		5	10	$\mu\text{A}$

### Note:

6. For this test, the data switch is closed with the respective switch pin floating.

## AC Electrical Characteristics

All typical value are for  $V_{CC}=3.3\text{ V}$  and  $T_A=25^\circ\text{C}$  unless otherwise specified.

Symbol	Parameter	Condition	$V_{CC}$ (V)	$T_A = -40^\circ\text{C}$ to $+85^\circ\text{C}$			Unit
				Min.	Typ.	Max.	
$t_{ON}$	MHL Turn-On Time, SEL to Output	$R_L=50\ \Omega$ , $C_L=5\ \text{pF}$ , $V_{SW(USB)}=0.8\ \text{V}$ , $V_{SW(MHL)}=3.3\ \text{V}$ , Figure 5, Figure 6	2.7 to 3.6 V		350	600	ns
$t_{OFF}$	MHL Turn-Off Time, SEL to Output	$R_L=50\ \Omega$ , $C_L=5\ \text{pF}$ , $V_{SW(USB)}=0.8\ \text{V}$ , $V_{SW(MHL)}=3.3\ \text{V}$ , Figure 5, Figure 6	2.7 to 3.6 V		125	300	ns
$t_{ZHM,ZLM}$	MHL Enable Time, /OE to Output	$R_L=50\ \Omega$ , $C_L=5\ \text{pF}$ , $V_{SW(MHL)}=3.3\ \text{V}$ , Figure 5, Figure 6	2.7 to 3.6 V		60	150	$\mu\text{s}$
$t_{ZHU,ZLU}$	USB Enable Time, /OE to Output	$R_L=50\ \Omega$ , $C_L=5\ \text{pF}$ , $V_{SW(USB)}=0.8\ \text{V}$ , Figure 5, Figure 6	2.7 to 3.6 V		100	300	ns
$t_{LZM,HZM}$	MHL Disable Time, /OE to Output	$R_L=50\ \Omega$ , $C_L=5\ \text{pF}$ , $V_{SW(MHL)}=3.3\ \text{V}$ , Figure 5, Figure 6	2.7 to 3.6 V		35	100	ns
$t_{LZU,HZU}$	USB Disable Time, /OE to Output	$R_L=50\ \Omega$ , $C_L=5\ \text{pF}$ , $V_{SW(USB)}=0.8\ \text{V}$ , Figure 5, Figure 6	2.7 to 3.6 V		35	100	ns
$t_{PD}$	Propagation Delay <sup>(7)</sup>	$C_L=5\ \text{pF}$ , $R_L=50\ \Omega$ , Figure 5, Figure 7	2.7 to 3.6 V		0.25		ns
$t_{BBM}$	Break-Before-Make <sup>(7)</sup>	$R_L=50\ \Omega$ , $C_L=5\ \text{pF}$ , $V_{ID}=V_{MHL}=3.3\ \text{V}$ , $V_{USB}=0.8\ \text{V}$ , Figure 9	2.7 to 3.6 V	2		13	ns
$O_{IRR(MHL)}$	Off Isolation <sup>(7)</sup>	$V_S=1\ \text{V}_{pk-pk}$ , $R_L=50\ \Omega$ , $f=240\ \text{MHz}$ , Figure 11	2.7 to 3.6 V		-55		dB
$O_{IRR(USB)}$		$V_S=400\ \text{mV}_{pk-pk}$ , $R_L=50\ \Omega$ , $f=240\ \text{MHz}$ , Figure 11	2.7 to 3.6 V		-45		dB
$Xtalk_{MHL}$	Non-Adjacent Channel <sup>(7)</sup> Crosstalk	$V_S=1\ \text{V}_{pk-pk}$ , $R=50\ \Omega$ , $f=240\ \text{MHz}$ , Figure 12	2.7 to 3.6 V		-47		dB
$Xtalk_{USB}$		$V_S=400\ \text{mV}_{pk-pk}$ , $R_L=50\ \Omega$ , $f=240\ \text{MHz}$ , Figure 12	2.7 to 3.6 V		-45		dB
BW (Insertion Loss)	Differential -3db Bandwidth <sup>(7)</sup>	$V_{IN}=1\ \text{V}_{pk-pk}$ , MHL Path, $R_L=50\ \Omega$ , $C_L=0\ \text{pF}$ , Figure 10, Figure 15	2.7 to 3.6 V		2.46		GHz
		$V_{IN}=400\ \text{mV}_{pk-pk}$ , USB Path, $R_L=50\ \Omega$ , $C_L=0\ \text{pF}$ , Figure 10, Figure 16			1.22		

**Note:**

7. Guaranteed by characterization.

## USB High-Speed AC Electrical Characteristics

Typical values are for  $V_{CC}=3.3$  V and  $T_A=25^\circ\text{C}$  unless otherwise specified.

Symbol	Parameter	Condition	$V_{CC}$ (V)	Typ.	Unit
$t_{SK(P)}$	Skew of Opposite Transitions of the Same Output <sup>(8)</sup>	$C_L=5$ pF, $R_L=50$ $\Omega$ , Figure 8	3.0 to 3.6	6	ps
$t_J$	Total Jitter <sup>(8)</sup>	$R_L=50$ $\Omega$ , $C_L=5$ pF, $t_R=t_F=500$ ps (10-90%) at 480 Mbps, PN7	3.0 to 3.6	15	ps

**Note:**

8. Guaranteed by characterization.

## MHL AC Electrical Characteristics

Typical values are for  $V_{CC}=3.3$  V and  $T_A=25^\circ\text{C}$  unless otherwise specified.

Symbol	Parameter	Condition	$V_{CC}$ (V)	Typ.	Unit
$t_{SK(P)}$	Skew of Opposite Transitions of the Same Output <sup>(9)</sup>	$R_{PU}=50$ $\Omega$ to $V_{CC}$ , $C_L=0$ pF	3.0 to 3.6 V	6	ps
$t_J$	Total Jitter <sup>(9)</sup>	$f=2.25$ Gbps, PN7, $R_{PU}=50$ $\Omega$ to $V_{CC}$ , $C_L=0$ pF	3.0 to 3.6 V	15	ps

**Note:**

9. Guaranteed by characterization.

## Capacitance

Typical values are for  $V_{CC}=3.3$  V and  $T_A=25^\circ\text{C}$  unless otherwise specified.

Symbol	Parameter	Condition	Typ.	Max.	Unit
$C_{IN}$	Control Pin Input Capacitance <sup>(10)</sup>	$V_{CC}=0$ V, $f=1$ MHz	2.1		pF
$C_{ON(USB)}$	USB Path On Capacitance <sup>(10)</sup>	$V_{CC}=3.3$ V, $f=240$ MHz, Figure 14	4.1	5.0	pF
$C_{OFF(USB)}$	USB Path Off Capacitance <sup>(10)</sup>	$V_{CC}=3.3$ V, $f=240$ MHz, Figure 13	2.8	3.2	pF
$C_{ON(MHL)}$	MHL Path On Capacitance <sup>(10)</sup>	$V_{CC}=3.3$ V, $f=240$ MHz, Figure 14	2.7	3.0	pF
$C_{OFF(MHL)}$	MHL Path Off Capacitance <sup>(10)</sup>	$V_{CC}=3.3$ V, $f=240$ MHz, Figure 13	1.1	1.5	pF

**Note:**

10. Guaranteed by characterization, not production tested.

## Test Diagrams

### Note:

11. HSD refers to the high-speed data on USB or MHL paths.

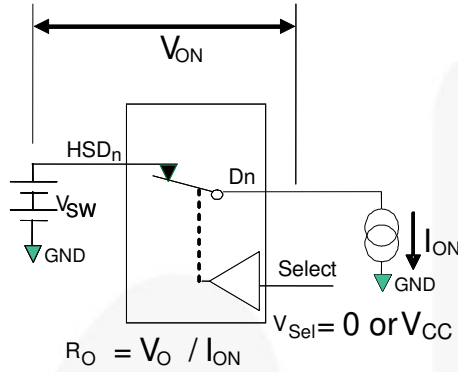
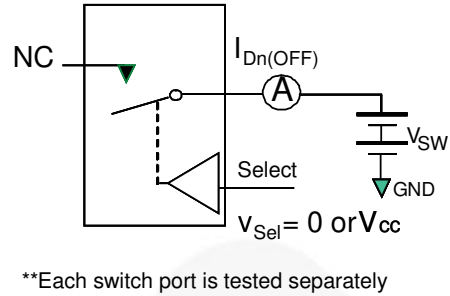
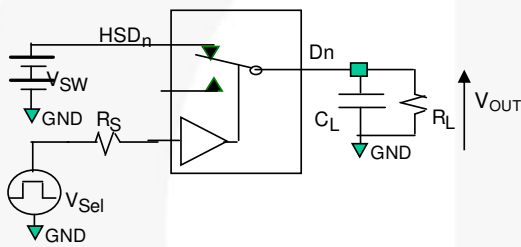

Figure 3. On Resistance



\*\*Each switch port is tested separately

Figure 4. Off Leakage



$R_L$ ,  $R_S$  and  $C_L$  are function of application environment (see AC Tables for specific values)  
 $C_L$  includes test fixture and stray capacitance

Figure 5. AC Test Circuit Load

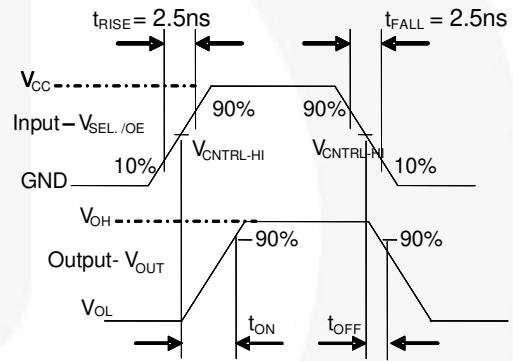

Figure 6. Turn-On / Turn-Off Waveforms

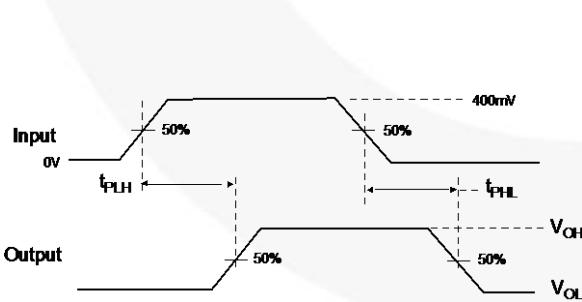

Figure 7. Propagation Delay ( $t_{rF} = 500$  ps)

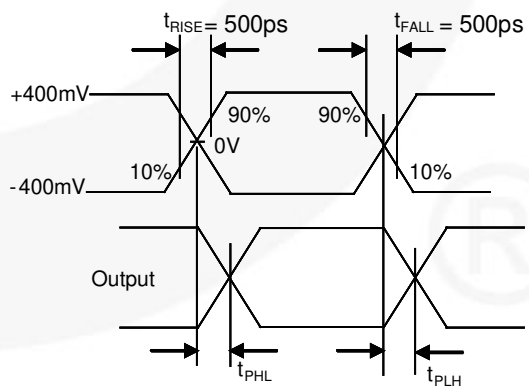
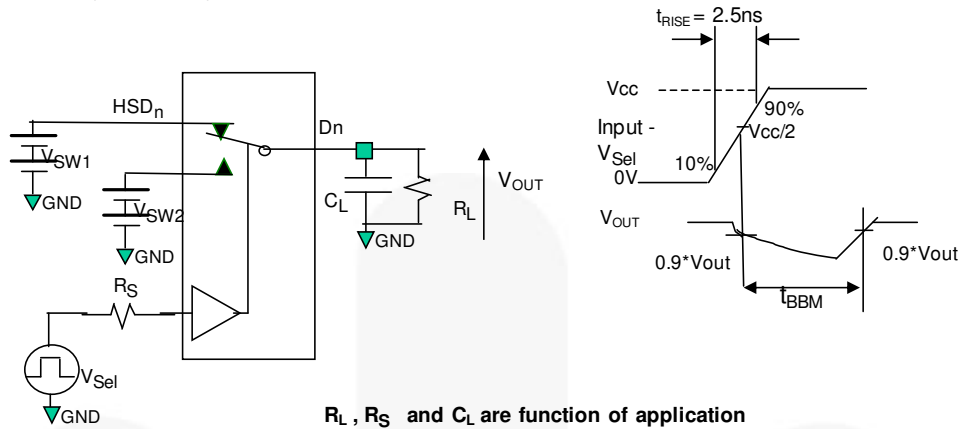

Figure 8. Intra-Pair Skew Test  $t_{SK(P)}$



**Test Diagrams** (Continued)



$R_L$ ,  $R_S$  and  $C_L$  are function of application environment (see AC Tables for specific values)  
 $C_L$  includes test fixture and stray capacitance

**Figure 9. Break-Before-Make Interval Timing**

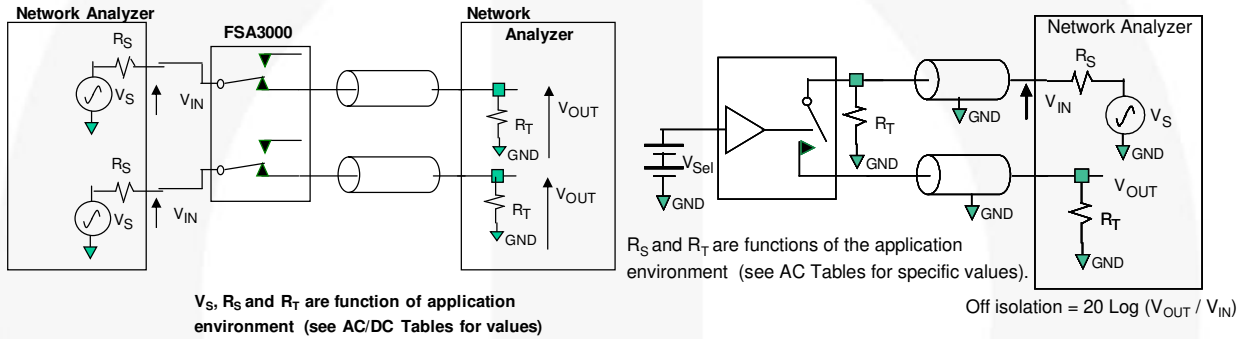

$V_S$ ,  $R_S$  and  $R_T$  are function of application environment (see AC/DC Tables for values)

**Figure 10. Insertion Loss**

$R_S$  and  $R_T$  are functions of the application environment (see AC Tables for specific values).

Off isolation =  $20 \text{ Log } (V_{OUT} / V_{IN})$

**Figure 11. Channel Off Isolation**

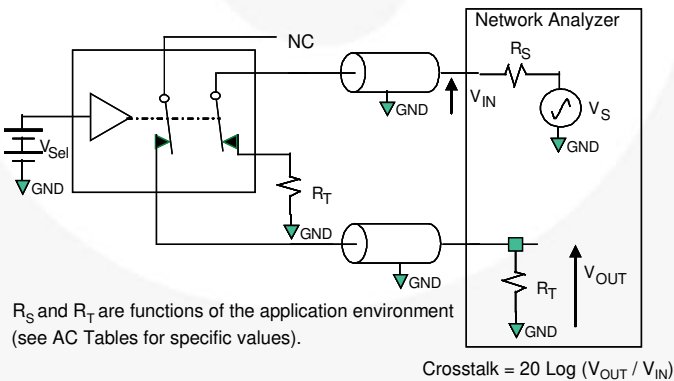

$R_S$  and  $R_T$  are functions of the application environment (see AC Tables for specific values).

Crosstalk =  $20 \text{ Log } (V_{OUT} / V_{IN})$

**Figure 12. Non-Adjacent Channel-to-Channel Crosstalk**

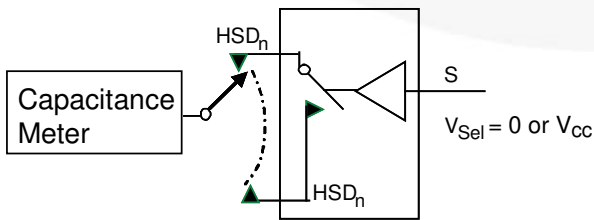

**Figure 13. Channel Off Capacitance**

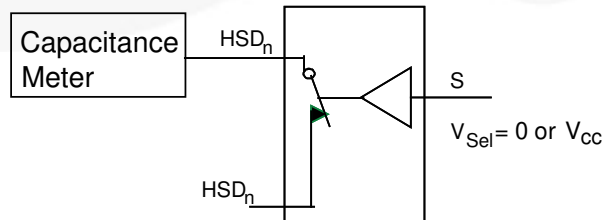

**Figure 14. Channel On Capacitance**

## Insertion Loss

One of the key factors for the FSA3000 in mobile digital video applications is the small amount of insertion loss in the received signal as it passes through the switch. This results in minimal degradation of the received eye. One of the ways to measure the quality of the high data rate channels is using balanced ports and 4-port differential S-parameter analysis, particularly SDD21.

Bandwidth is measured using the S-parameter SDD21 methodology. Figure 15 shows the bandwidth (GHz) for the MHL path and Figure 16 shows the bandwidth curve for the USB path.

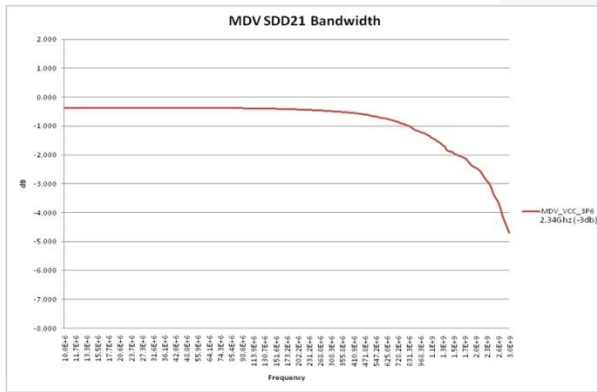

Figure 15. MHL (MDV) Path SDD21 Insertion Loss Curve

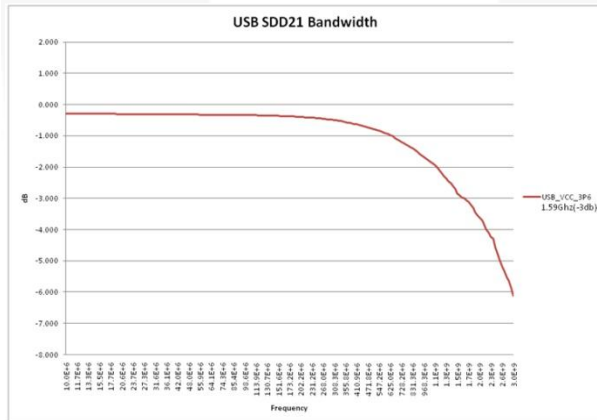

Figure 16. USB Path SDD21 Insertion Loss Curve

## Typical Application

Figure 17 shows a typical mobile application using the FSA3000 for MHL switching. The FSA3157 is used for OTG dual-role device implementations where the CBUS of MHL and the ID pin for USB needs to be switched. The 3M resistor for MHL\_SEL is optional to ensure that on power up the USB switch path is selected as default.

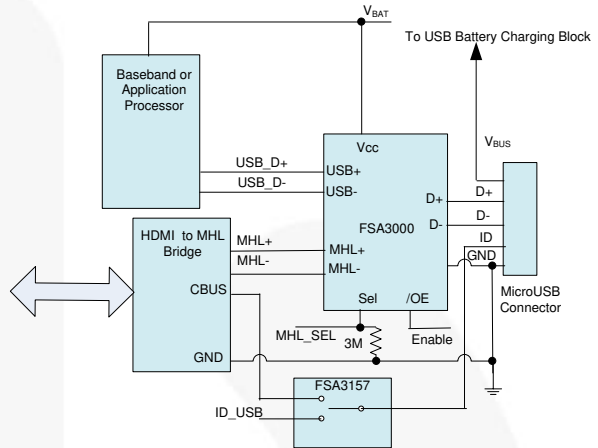

Figure 17. Typical Mobile MHL Application

# Packing Specifications

## MicroPak 1.6x2.1 F131, Packing Drawing



### Packing Description:

MicroPak 1.6x2.1 F131 products are classified under Moisture Sensitive Level 1.

The carrier tape is made from dissipative polystyrene or polycarbonate resin. The cover tape is a multilayer film primarily composed of polyester film, adhesive layer, heat activated sealant, and anti-static sprayed agent. These reeled parts in standard option are shipped with 5000 units per 178 mm diameter reel. Up to three reels are packed in each intermediate box. The reels is made of polystyrene plastic (anti-static coated or intrinsic).

These full reels are individually barcode labeled and placed inside a pizza box made of recyclable corrugated brown paper with a Fairchild logo printing. Up to 3 reels could be packed in the pizza box. And these pizza boxes are placed inside a barcode labeled shipping box which comes in different sizes depending on the number of parts shipped.

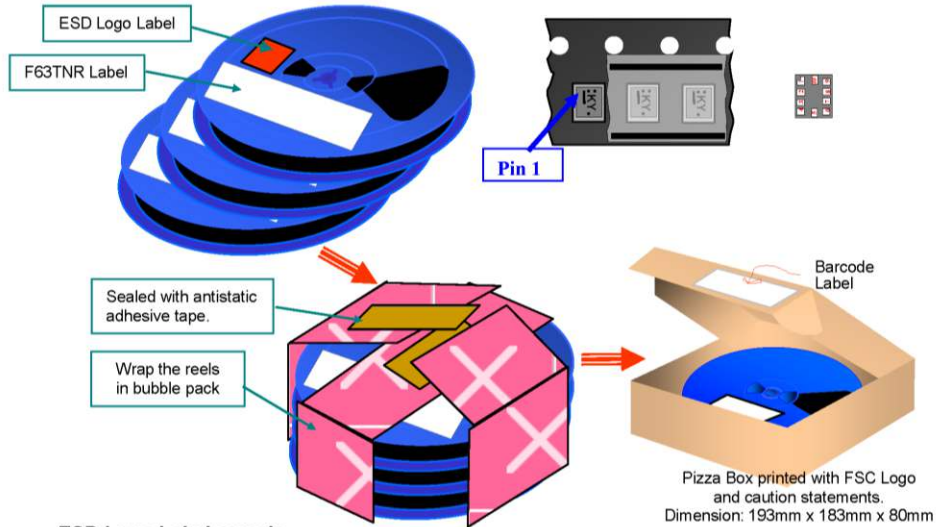

### ESD Logo Label sample



### F63TNR Label sample

LOT: PMH01008888	QTY: 5000
FSID: FSA831L10X	SPEC: F131
D/C1: P1136AA QTY1:	SPEC REV: 2 <sup>nd</sup> Level Interconnect
D/C2: QTY2:	1. Category G4
Green Component	2. Maximum safe temperature 260 deg C
RoHS COMPLIANT	3. MSL 1
	FAIRCHILD SEMICONDUCTOR (F63TNR)0.0

### Tape Leader and Trailer Configuration

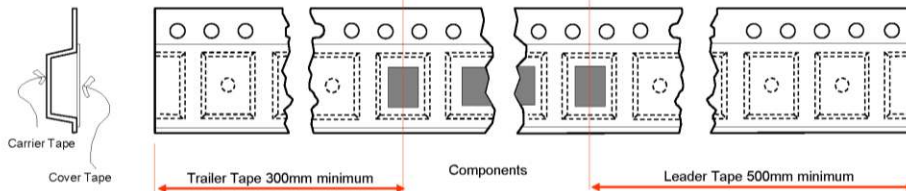
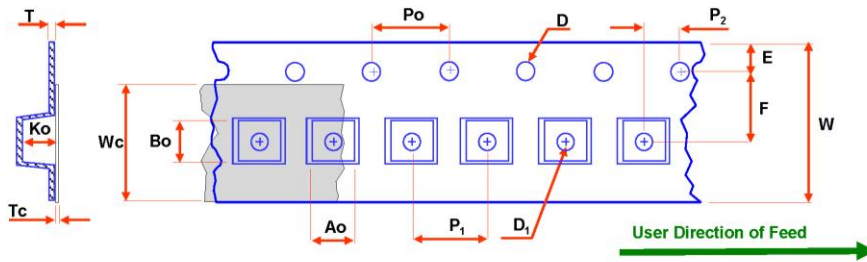

Figure 18. MicroPak™ 1.6 x 2.1 mm, Packing Drawing, Page 1

## Packing Specifications (Continued)

### Embossed Tape Dimension



Dimensions are in millimeters

Package	Ao +/-0.05	Bo +/-0.05	D +/-0.10	D <sub>1</sub> min.	E +/-0.1	F +/-0.1	Ko +/-0.05	P <sub>1</sub> TYP	Po TYP	P <sub>2</sub> +/-0.05	T TYP	Tc +/-0.005	W +/-0.3	Wc TYP
MAC10A	1.83	2.34	1.5	0.5	1.75	3.5	0.65	4	4	2.0	0.254	0.06	8	5.3

Notes: Ao, Bo, and Ko dimensions are determined with respect to the EIA/Jedec RS-481 rotational and lateral movement requirements (see sketches A, B, and C).

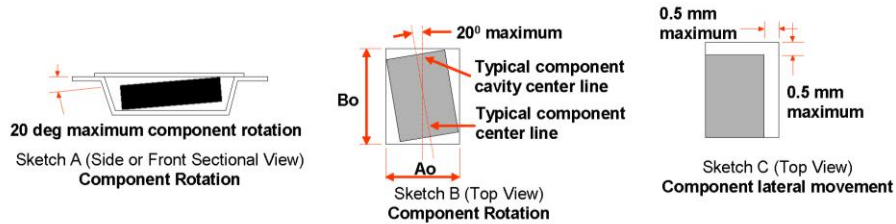

### Shipping Reel Dimension

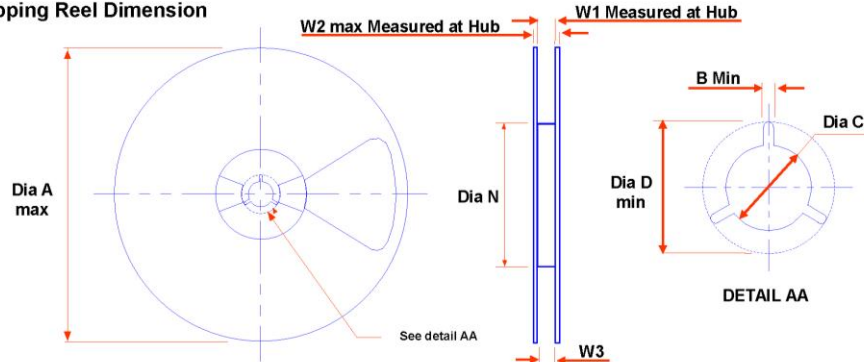

Dimensions are in millimeters

Tape Width	Dia A max	Dim B min	Dia C +5/-2	Dia D min	Dim N min	Dim W1 +2/-0	Dim W2 max	Dim W3 (LSL - USL)
8	178	1.5	13	20.2	55	8.4	14.4	7.9~10.4

APPROVALS	DATE		
DESIGN			
DRG. CHG.			
ENGR. CHG.			
		<b>MicroPak 1.6x2.1 F131</b> Packing Configuration	
SCALE	SIZE	DRAWING NUMBER	REV
1:1	N/A	PKG - MAC10A-F131	1
DO NOT SCALE DRAWING!			SHEET 1 of 1

Figure 19. MicroPak™ 1.6 x 2.1 mm, Packing Drawing, Page 2

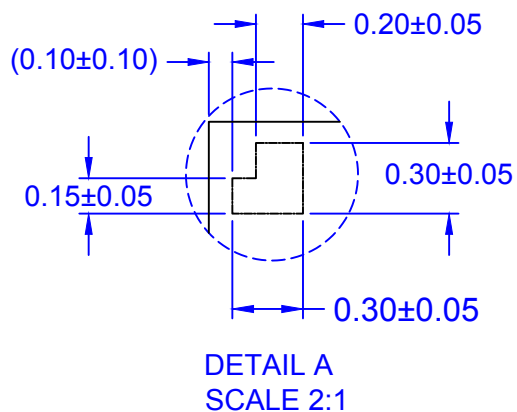
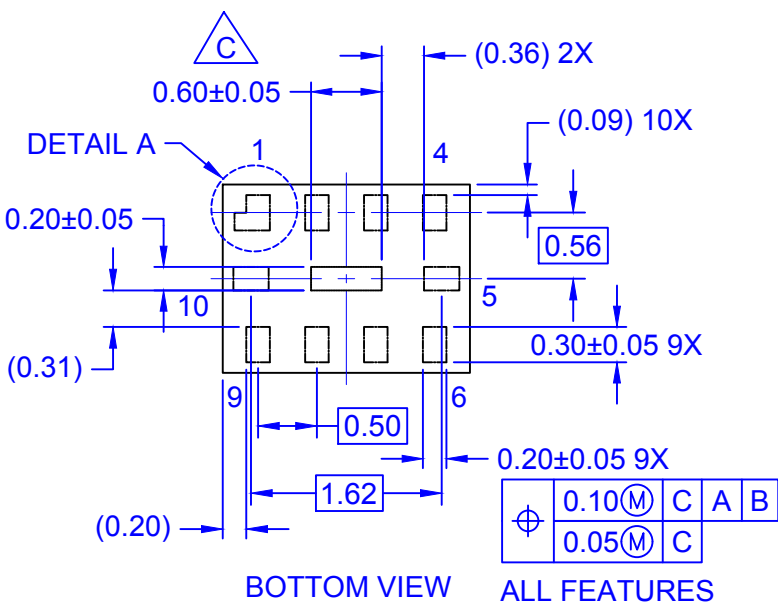
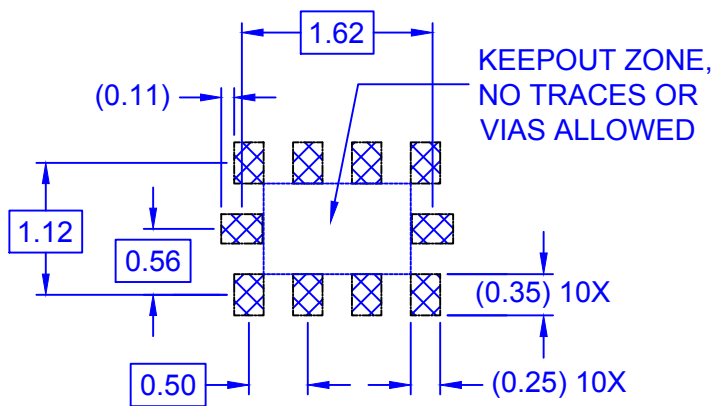
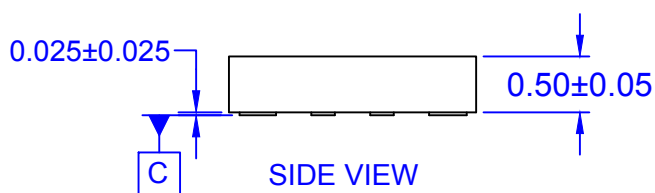
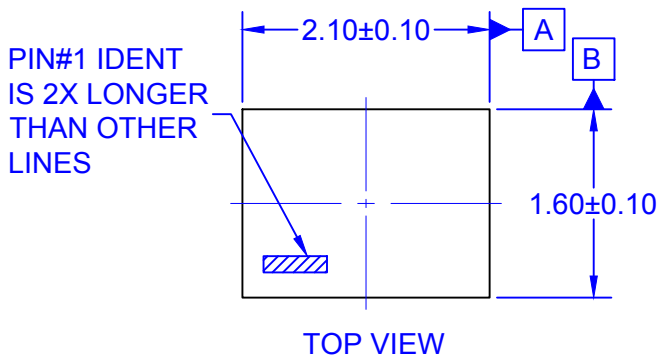

NOTES:

- A. PACKAGE CONFORMS TO JEDEC REGISTRATION MO-255, VARIATION UABD.
- B. DIMENSIONS ARE IN MILLIMETERS.
- C. PRESENCE OF CENTER PAD IS PACKAGE SUPPLIER DEPENDENT. IF PRESENT IT IS NOT INTENDED TO BE SOLDERED AND HAS A BLACK OXIDE FINISH.
- D. DRAWING FILENAME: MKT-MAC10ArevG.
- E. DIMENSIONS WITHIN ( ) ARE UNCONTROLLED.

ON Semiconductor



ON Semiconductor and  are trademarks of Semiconductor Components Industries, LLC dba ON Semiconductor or its subsidiaries in the United States and/or other countries. ON Semiconductor owns the rights to a number of patents, trademarks, copyrights, trade secrets, and other intellectual property. A listing of ON Semiconductor's product/patent coverage may be accessed at [www.onsemi.com/site/pdf/Patent-Marking.pdf](http://www.onsemi.com/site/pdf/Patent-Marking.pdf). ON Semiconductor reserves the right to make changes without further notice to any products herein. ON Semiconductor makes no warranty, representation or guarantee regarding the suitability of its products for any particular purpose, nor does ON Semiconductor assume any liability arising out of the application or use of any product or circuit, and specifically disclaims any and all liability, including without limitation special, consequential or incidental damages. Buyer is responsible for its products and applications using ON Semiconductor products, including compliance with all laws, regulations and safety requirements or standards, regardless of any support or applications information provided by ON Semiconductor. "Typical" parameters which may be provided in ON Semiconductor data sheets and/or specifications can and do vary in different applications and actual performance may vary over time. All operating parameters, including "Typicals" must be validated for each customer application by customer's technical experts. ON Semiconductor does not convey any license under its patent rights nor the rights of others. ON Semiconductor products are not designed, intended, or authorized for use as a critical component in life support systems or any FDA Class 3 medical devices or medical devices with a same or similar classification in a foreign jurisdiction or any devices intended for implantation in the human body. Should Buyer purchase or use ON Semiconductor products for any such unintended or unauthorized application, Buyer shall indemnify and hold ON Semiconductor and its officers, employees, subsidiaries, affiliates, and distributors harmless against all claims, costs, damages, and expenses, and reasonable attorney fees arising out of, directly or indirectly, any claim of personal injury or death associated with such unintended or unauthorized use, even if such claim alleges that ON Semiconductor was negligent regarding the design or manufacture of the part. ON Semiconductor is an Equal Opportunity/Affirmative Action Employer. This literature is subject to all applicable copyright laws and is not for resale in any manner.

## PUBLICATION ORDERING INFORMATION

### LITERATURE FULFILLMENT:

Literature Distribution Center for ON Semiconductor  
19521 E. 32nd Pkwy, Aurora, Colorado 80011 USA  
**Phone:** 303-675-2175 or 800-344-3860 Toll Free USA/Canada  
**Fax:** 303-675-2176 or 800-344-3867 Toll Free USA/Canada  
**Email:** [orderlit@onsemi.com](mailto:orderlit@onsemi.com)

**N. American Technical Support:** 800-282-9855 Toll Free  
USA/Canada  
**Europe, Middle East and Africa Technical Support:**  
Phone: 421 33 790 2910  
**Japan Customer Focus Center**  
Phone: 81-3-5817-1050

**ON Semiconductor Website:** [www.onsemi.com](http://www.onsemi.com)  
**Order Literature:** <http://www.onsemi.com/orderlit>  
For additional information, please contact your local  
Sales Representative