

DESCRIPTION

The CNW135, CNW136 and CNW4502 are fast-switching optocouplers, consisting of an AlGaAs LED optically coupled to a high speed photodetector transistor in a wide 8-pin dual-in-line (DIL) plastic envelope.

The CNW4502 provides the same electrical switching and isolation performances as the CNW136, and increased ESD protection due to a non-connected base.

FEATURES

- Wide body DIL encapsulation, with a pin distance of 10.16 mm
- Minimum clearance of 9.6 mm and minimum creepage of 10 mm
- 11 MHz bandwidth
- Short propagation delay times
- TTL compatible
- Low saturation voltage
- High transient immunity
- High degree of AC and DC insulation (5000 V (RMS) and 7070 V (DC)) in accordance with UL 1577 and IEC/BSI specifications
- Maximum permissible voltage of 8000 V (peak) and maximum operating isolation voltage of 1000 V (RMS) in accordance with VDE 00884
- UL recognize (File #E90700)

APPLICATIONS

- Video signal isolation
- Feedback element in SMPS
- Line receivers
- High-speed logic ground isolation
- Analog signal ground isolation
- Replace pulse transformers

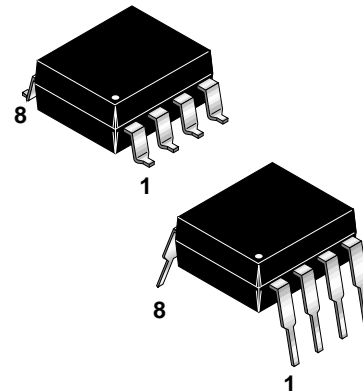
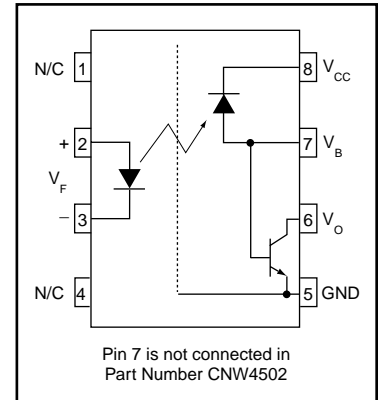

ABSOLUTE MAXIMUM RATINGS ($T_A = 25^\circ\text{C}$ unless otherwise specified)				
Parameters	Symbol	Device	Value	Units
TOTAL DEVICE				
Storage Temperature	T_{STG}	All	-55 to +150	$^\circ\text{C}$
Operating Temperature	T_{OPR}	All	-55 to +85	$^\circ\text{C}$
Lead Solder Temperature	T_{SOL}	All	260 for 10 sec	$^\circ\text{C}$
EMITTER				
Continuous Reverse Voltage (DC)	V_R	All	5	V
Continuous Forward Current	I_F	All	100	mA
Forward Current - Peak ($t_p = 1 \mu\text{s}$, $f = 300 \text{ Hz}$)	$I_F(pk)$	All	1	A
Total Power Dissipation up to 70°C Ambient	P_D	All	250	mW
DETECTOR				
DC Collector Current	I_C	All	10	mA
Supply Voltage (pins 8 & 5)	V_{CC}	All	-0.5 to 30	V
Collector to Emitter Voltage (pins 6 & 5)	V_{CEO}	All	-0.5 to 20	V
Emitter to Base Voltage (pins 7 & 5)	V_{EBO}	CNW135, CNW136	5	V
Total Power Dissipation up to 70°C	P_D	All	100	mW

ELECTRICAL CHARACTERISTICS ($T_A = 25^\circ\text{C}$ Unless otherwise specified)							
INDIVIDUAL COMPONENT CHARACTERISTICS							
Parameter	Test Conditions	Symbol	Device	Min	Typ*	Max	Unit
EMITTER Forward Voltage	$I_F = 16\text{ mA}$	V_F	All	1.25	1.6	1.7	V
	$I_F = 16\text{ mA}, T_A = 0\text{ to }70^\circ\text{C}$		All	1.2		1.8	
Input Reverse Voltage	$V_R = 5\text{ V}$	I_R	All			10	μA
	$V_R = 5\text{ V}, T_A = 0\text{ to }70^\circ\text{C}$		All			100	
Diode Capacitance	$V_D = 0, f = 1\text{ MHz}$	C_d	All		200		pF
DETECTOR							
Collector-Emitter Breakdown Voltage	$I_C = 1.0\text{ mA}$	BV_{CEO}	All	20			V
Emitter-Base Breakdown Voltage	$I_C = 0.1\text{ mA}$	BV_{EBO}	CNW135, CNW136	5			V
Logic High Output Current	$I_F = 0\text{ mA}, V_O = V_{CC} = 5.5\text{ V}$	I_{OH}	All		0.005	0.5	μA
	$I_F = 0\text{ mA}, V_O = V_{CC} = 15\text{ V}$				0.01	1	
	$I_F = 0\text{ mA}, V_O = V_{CC} = 5.5\text{ V}, T_A = 0\text{ to }70^\circ\text{C}$					50	
Logic High Supply Current	$I_F = 0\text{ mA}, I_O = 0, V_{CC} = 15\text{ V}$	I_{CCH}	All		0.001	1	μA
	$I_F = 0\text{ mA}, I_O = 0, V_{CC} = 15\text{ V}, T_A = 0\text{ to }70^\circ\text{C}$					2	
Logic Low Supply Current	$I_F = 16\text{ mA}, I_O = 0, V_{CC} = 15\text{ V}$	I_{CCL}	All		80	200	μA

TRANSFER CHARACTERISTICS ($T_A = 25^\circ\text{C}$ Unless otherwise specified)							
Parameter	Test Conditions	Symbol	Device	Min	Typ*	Max	Unit
TOTAL DEVICE Current Transfer Ratio	$I_F = 16\text{ mA}, V_O = 0.4\text{ V}, V_{CC} = 4.5\text{ V}, T_A = 0\text{ to }25^\circ\text{C}, \text{DC}$	CTR	CNW135	7			%
			CNW136/4502	19			
	$I_F = 16\text{ mA}, V_O = 0.4\text{ V}, V_{CC} = 4.5\text{ V}, T_A = 0\text{ to }70^\circ\text{C}, \text{DC}$		CNW135	5			
			CNW136/4502	15			
Logic Low Output Voltage	$I_F = 16\text{ mA}, I_C = 1.1\text{ mA}, V_{CC} = 4.5\text{ V}$	V_{OL}	CNW135			0.4	V
	$I_F = 16\text{ mA}, I_C = 3\text{ mA}, V_{CC} = 4.5\text{ V}$		CNW136/4502			0.4	
	$I_F = 16\text{ mA}, I_C = 0.8\text{ mA}, V_{CC} = 4.5\text{ V}, T_A = 0\text{ to }25^\circ\text{C}$		CNW135			0.5	
	$I_F = 16\text{ mA}, I_C = 2.4\text{ mA}, V_{CC} = 4.5\text{ V}, T_A = 0\text{ to }70^\circ\text{C}$		CNW136/4502			0.5	
Bandwidth		B	All		11		MHz

SWITCHING CHARACTERISTICS (see Fig. 9) ($T_A = 25^\circ\text{C}$ Unless otherwise specified)							
Parameter	Test Conditions	Symbol	Device	Min	Typ*	Max	Unit
Propagation delay time to logic low at output	$R_L = 4.1\text{ k}\Omega, I_F = 16\text{ mA}, V_{CC} = 5\text{ V}$	T_{PHL}	CNW135		0.5	1.5	μs
	$R_L = 4.1\text{ k}\Omega, I_F = 16\text{ mA}, V_{CC} = 5\text{ V}, 0\text{ to }70^\circ\text{C}$					2.0	
	$R_L = 1.9\text{ k}\Omega, I_F = 16\text{ mA}, V_{CC} = 5\text{ V}$		CNW136/4502		0.55	0.8	
	$R_L = 1.9\text{ k}\Omega, I_F = 16\text{ mA}, V_{CC} = 5\text{ V}, 0\text{ to }70^\circ\text{C}$					1.0	
Propagation delay time to logic high at output	$R_L = 4.1\text{ k}\Omega, I_F = 16\text{ mA}, V_{CC} = 5\text{ V}$	T_{PLH}	CNW135		0.7	1.5	μs
	$R_L = 4.1\text{ k}\Omega, I_F = 16\text{ mA}, V_{CC} = 5\text{ V}, 0\text{ to }70^\circ\text{C}$					2.0	
	$R_L = 1.9\text{ k}\Omega, I_F = 16\text{ mA}, V_{CC} = 5\text{ V}$		CNW136/4502		0.35	0.8	
	$R_L = 1.9\text{ k}\Omega, I_F = 16\text{ mA}, V_{CC} = 5\text{ V}, 0\text{ to }70^\circ\text{C}$					1.0	

* Typical values at $T_A = 25^\circ\text{C}$

CNW135 CNW136 CNW4502

TRANSIENT IMMUNITY (see Fig. 10)							
Parameter	Test Conditions	Symbol	Device	Min	Typ*	Max	Unit
Common mode transient immunity at logic high	$R_L = 4.1\text{ k}\Omega, I_F = 0, V_{CC} = 5\text{ V}, V_{CM} = 10\text{ V}_{(p-p)}$	$ CM_H $	CNW135	1			kV/ μ s
	$R_L = 1.9\text{ k}\Omega, I_F = 0, V_{CC} = 5\text{ V}, V_{CM} = 10\text{ V}_{(p-p)}$		CNW136/4502	1			
Common mode transient immunity at logic low	$R_L = 4.1\text{ k}\Omega, I_F = 16\text{ mA}, V_{CC} = 5\text{ V}, V_{CM} = 10\text{ V}_{(p-p)}$	$ CM_L $	CNW135	-1			kV/ μ s
	$R_L = 1.9\text{ k}\Omega, I_F = 16\text{ mA}, V_{CC} = 5\text{ V}, V_{CM} = 10\text{ V}_{(p-p)}$		CNW136/4502	-1			
Common mode rejection ratio	$R_L = 1\text{ k}\Omega, I_C = 6\text{ mA}, f = 10\text{ kHz}, V_{CC} = 10\text{ V}$	CMRR	All		-80		dB

ISOLATION CHARACTERISTICS							
Characteristic	Test Conditions	Symbol	Min	Typ*	Max	Units	
Maximum Operating Isolation Voltage	RH = 50%, t = 1 min., 25°C	V_{ISO}	5000			V_{RMS}	
Isolation Resistance	$V_{I-O} = 500\text{ V/DC}, 25^\circ\text{C}$	R_{ISO}	10^{12}	10^{13}		Ω	
Isolation Capacitance	$V_{I-O} = 0\text{ V}, f = 1\text{ MHz}$	C_{ISO}		0.4	0.6	pF	

* Typical values at $T_A = 25^\circ\text{C}$

Fig. 1 LED Forward Current vs. Forward Voltage

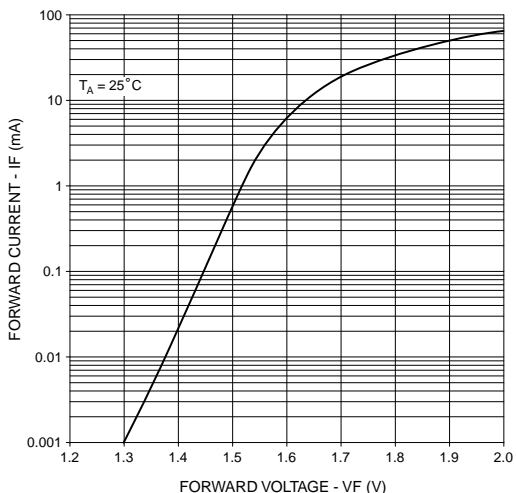

Fig. 2 Normalized CTR vs. Forward Current

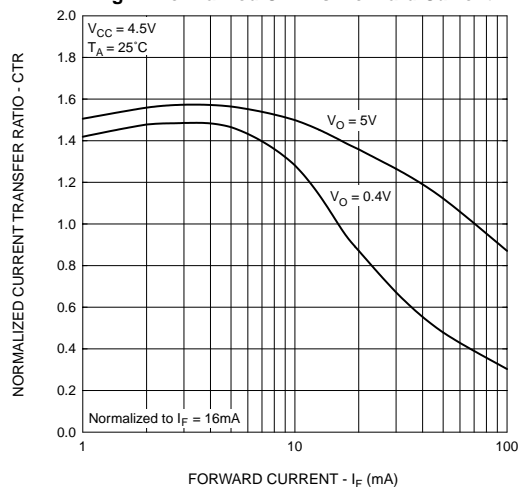

Fig. 3 Normalized CTR vs. Ambient Temperature

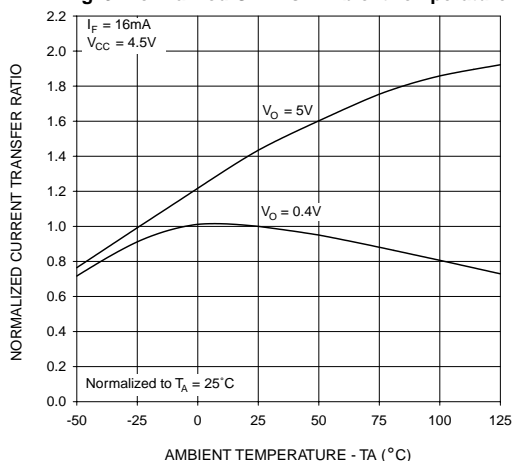

Fig. 4 Output Current vs. Output Voltage

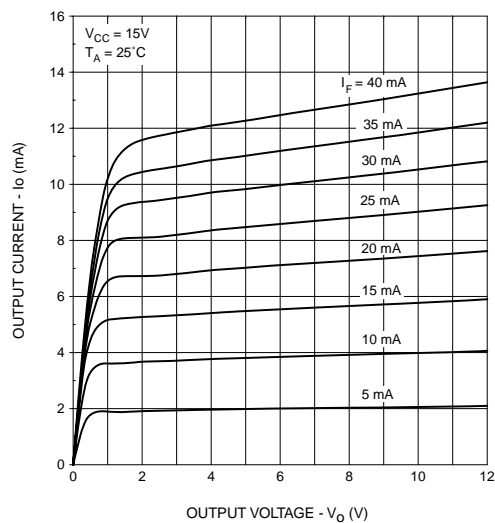

Fig. 5 Logic High Output Current vs. Ambient Temperature

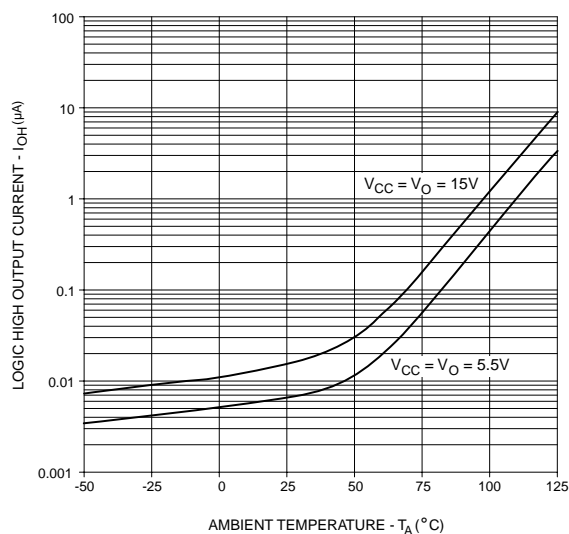

Fig. 6 Propagation Delay vs. Ambient Temperature

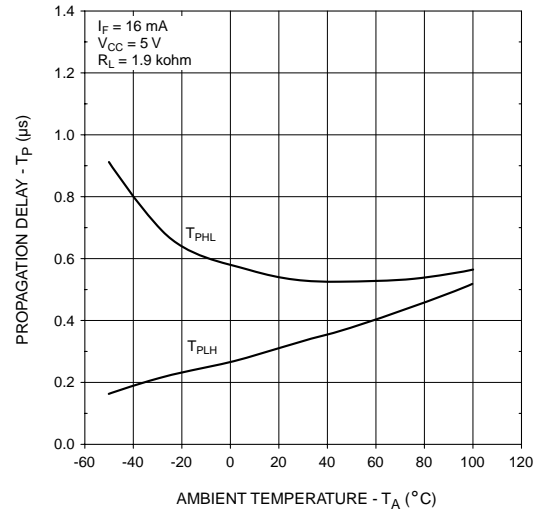
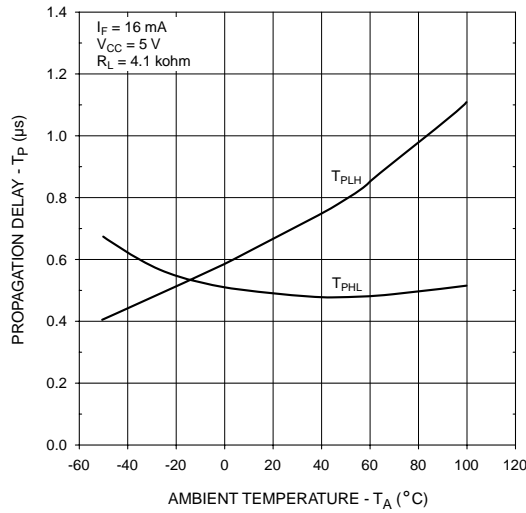

Fig. 7 Logic Low Supply Current vs. Forward Current

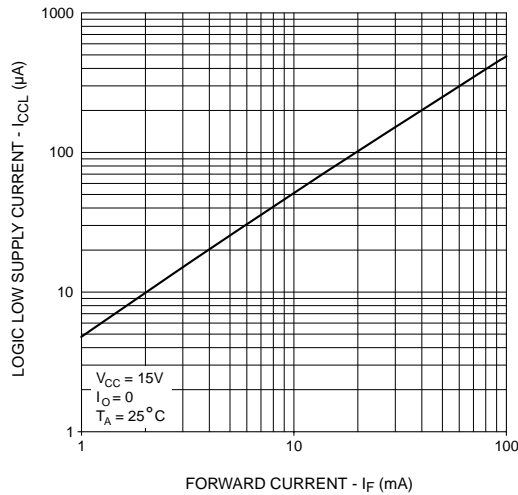
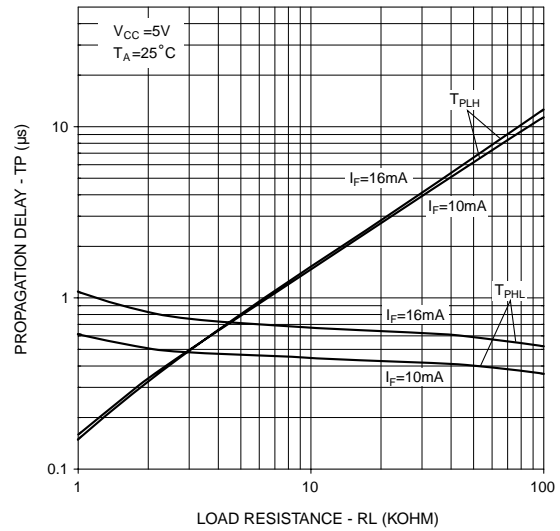

Fig. 8 Propagation Delay vs. Load Resistance



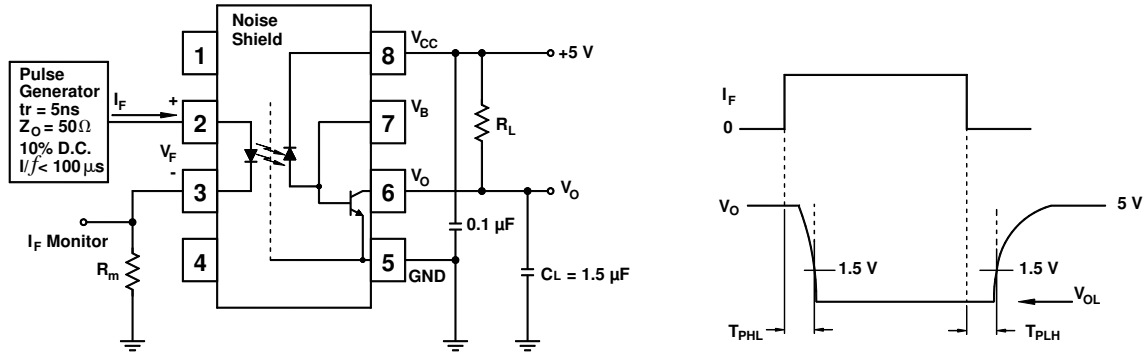

Fig.9 Switching Time Test Circuit

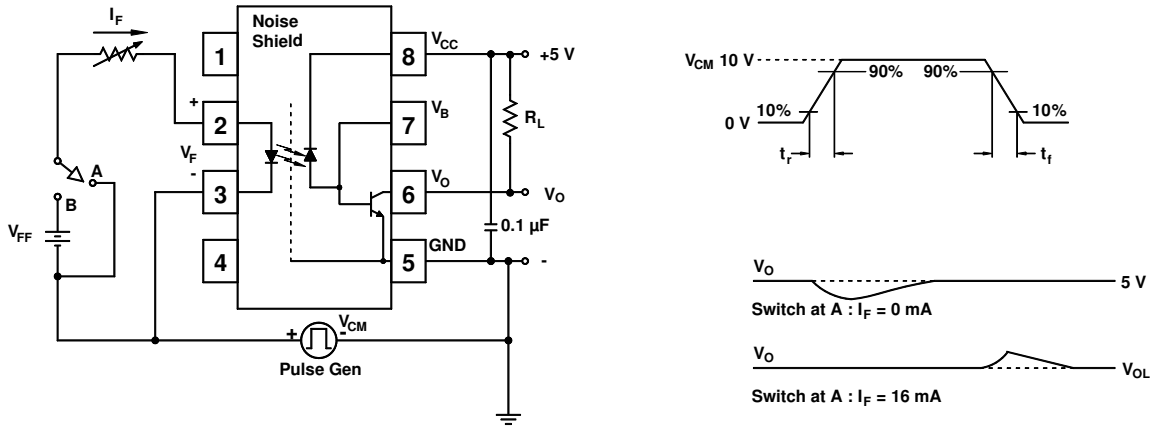
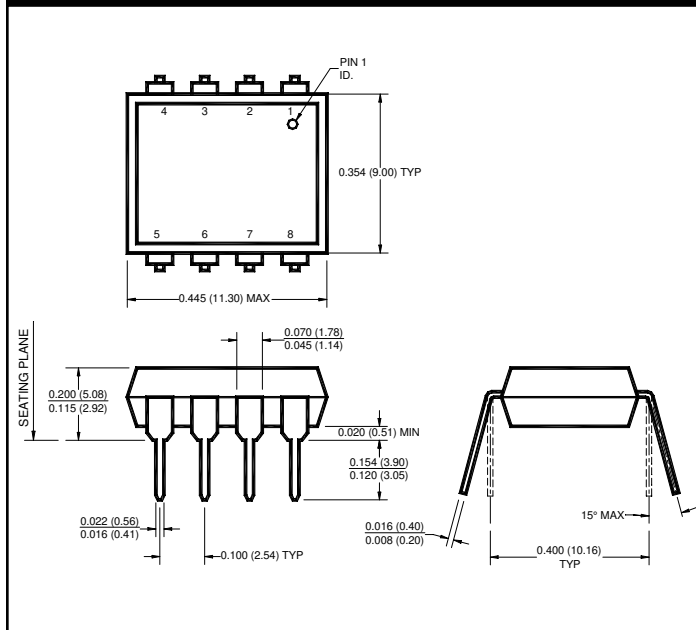
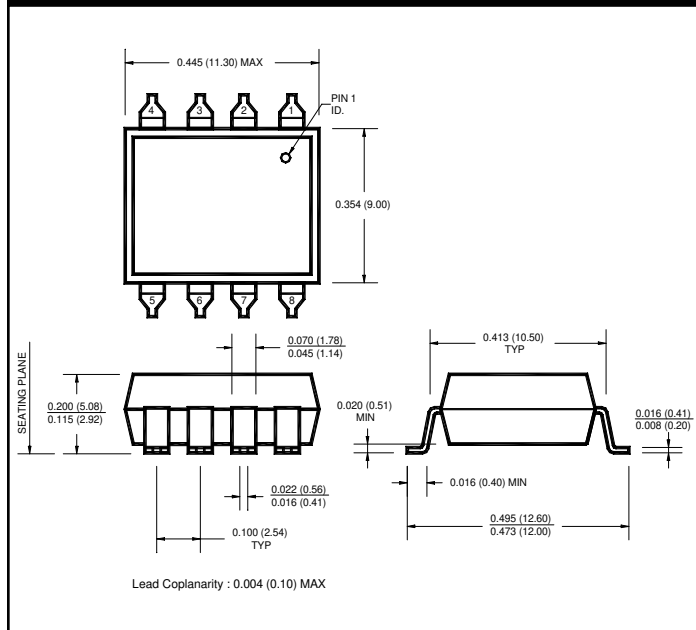

Fig.10 Common Mode Immunity Test Circuit

Package Dimensions (Through Hole)



Package Dimensions (Surface Mount)



NOTE

All dimensions are in inches (millimeters)

ORDERING INFORMATION

Option	Order Entry Identifier	Description
S	.S	Surface Mount Lead Bend
300	.300	VDE 0884

DISCLAIMER

FAIRCHILD SEMICONDUCTOR RESERVES THE THE RIGHT TO MAKE CHANGES WITHOUT FURTHER NOTICE TO ANY PRODUCTS HEREIN TO IMPROVE RELIABILITY, FUNCTION OR DESIGN. FAIRCHILD DOES NOT ASSUME ANY LIABILITY ARISING OUT OF THE APPLICATION OR USE OF ANY PRODUCT OR CIRCUIT DESCRIBED HEREIN; NEITHER DOES IT CONVEY ANY LICENSE UNDER ITS PATENT RIGHTS, NOR THE RIGHTS OF OTHERS.

LIFE SUPPORT POLICY

FAIRCHILD'S PRODUCTS ARE NOT AUTHORIZED FOR USE AS CRITICAL COMPONENTS IN LIFE SUPPORT DEVICES OR SYSTEMS WITHOUT THE EXPRESS WRITTEN APPROVAL OF THE PRESIDENT OF FAIRCHILD SEMICONDUCTOR CORPORATION. As used herein:

1. Life support devices or systems are devices or systems which, (a) are intended for surgical implant into the body, or (b) support or sustain life, and (c) whose failure to perform when properly used in accordance with instructions for use provided in labeling, can be reasonably expected to result in a significant injury of the user.
2. A critical component in any component of a life support device or system whose failure to perform can be reasonably expected to cause the failure of the life support device or system, or to affect its safety or effectiveness.