

ISL78600EVKIT1Z

User's Manual: Evaluation Board

Battery Management

All information contained in these materials, including products and product specifications, represents information on the product at the time of publication and is subject to change by Renesas Electronics Corp. without notice. Please review the latest information published by Renesas Electronics Corp. through various means, including the Renesas Electronics Corp. website (<http://www.renesas.com>).

ISL78600EVKIT1Z

Evaluation Kit

1. Overview

The ISL78600EVKIT1Z is an evaluation kit that facilitates testing of the [ISL78600](#) Li-ion battery pack analog front-end ICs. The ISL78600 monitors cell voltage and temperature. It converts the cell voltages and temperatures to 14-bit digital values, provides cell balance control, and provides significant fault detection. The ISL78600 also contains daisy chain hardware to provide robust, redundant, board-to-board communication.

The evaluation kit can be used as a stand-alone monitor or combined with additional boards to create a daisy chained application. One board, operating alone, allows testing of up to 12-cell series-connected Li-ion battery packs, using a standard USB interface to a PC. Up to 14 boards cascade (with daisy chain communication from board-to-board) to test systems with up to 168 cells.

1.1 Key Features

- Supports both stand-alone and daisy chained configurations
- Daisy chaining with both connector only or wire jumper options
- GUI provided export option for generation of detailed register and/or SPI communications log files
- USB dongle runs HID firmware for driver-less enumeration and communications with Windows platforms
- GUI add-in chart generation tool supports real-time graphing, zoom, and export of captured data
- Software provides checksum requirements associated with daisy chain communications
- Evaluation kit includes a “Battery Emulation” power supply board for cell voltage generation

1.2 Specifications

This board is configured and optimized for the following operating conditions:

- $V_{BAT} = 6V$ to $60V$
- V_{BAT} daisy chain = $10V$ to $60V$
- VC_n (for $n = 1$ to 12) = $V(VC_{n-1})$ to $V(VC_{n-1}) + 5V$
- CB_n (for $n = 1$ to 9) = $V(VC_{n-1})$ to $V(VC_{n-1}) + 9V$
- CB_n (for $n = 10$ to 12) = $V(VC_n) - 9V$ to $V(VC_n)$
- External inputs $ExT1$ to $ExT4 = 0V$ to $2.5V$ (external temperature measurement thermistors on board)

1.3 Ordering Information

Part Number	Description
ISL78600EVKIT1Z	Evaluation Kit for the ISL78600EVAL2Z Rev C

1.4 Related Literature

For a full list of related documents, please visit our website:

- [ISL78600](#) device page

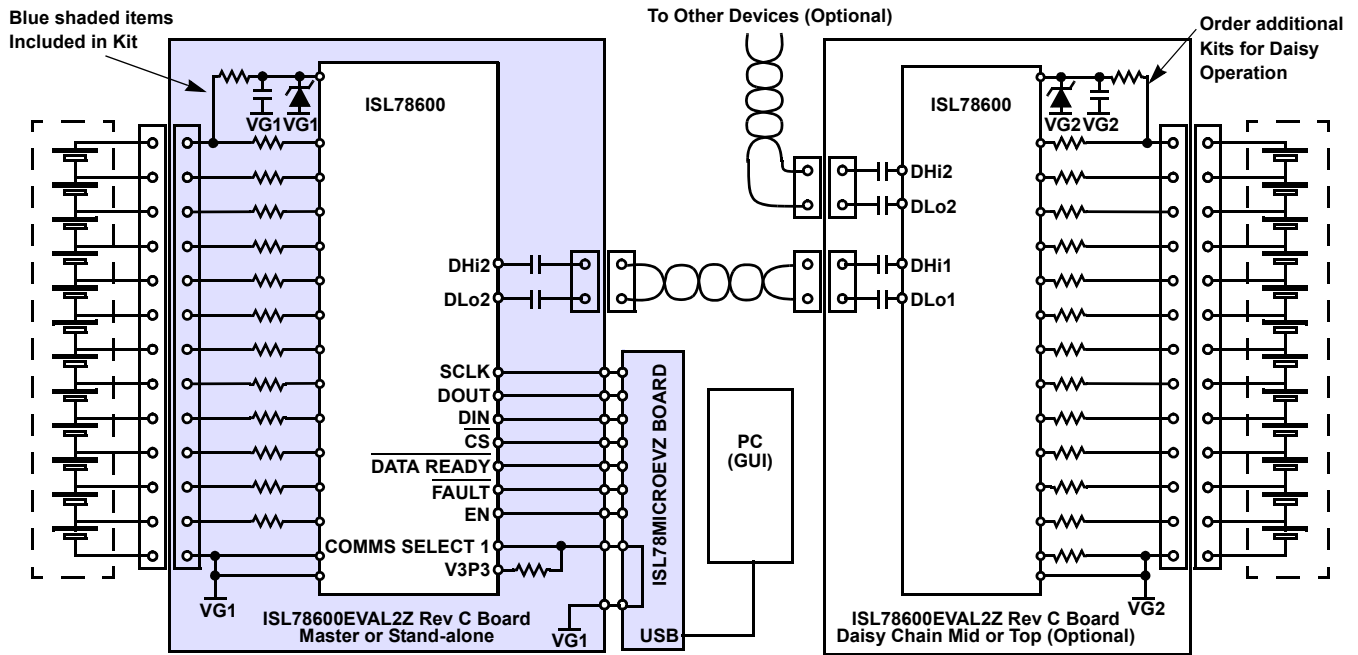

Figure 1. Typical Application

1.5 What is Inside

The ISL78600EVKIT1Z evaluation kit contains the following:

- ISL78600EVAL2Z Rev C evaluation board
- MCB_PS3_Z multicell power supply test board
- ISL78MICROEVZ USB to SPI Microcontroller dongle
- USB cable, which connects PC to evaluation board
- One daisy chain cable
- USB drive with GUI install code and documentation

1.6 What is Needed

The following instruments is needed to perform testing:

- 60V/1A adjustable power supply
- Wires to connect power supply to MCB_PS3_Z board
- Precision multimeter
- Windows computer with USB port
- One (or two) 24V/1A wall power supplies with 2.1mm power jack - connects to GUI. Includes power jack model PJ-102A. The MCB_PS3_Z board can use these for supplies instead of an adjustable supply (optional).
- Oscilloscope (optional)
- Cables and wires (optional)

2. Functional Description

The ISL78600EVKIT1Z evaluation kit, coupled with the associated GUI, provides the means to familiarize yourself with the various instructions capability and operation of the device. A single ISL78600 Li-ion battery manager IC supervises up to 12 series-connected cells. The part provides accurate monitoring, cell balancing, and extensive system diagnostics functions.

The kit enables you to activate and data log voltage and temperature measurements. Cell voltages are supplied using a resistor ladder network in the MCB_PS3_Z multicell power supply test board.

The ISL78600 has three cell balancing modes incorporated: Manual Balance mode, Timed Balance mode, and Auto Balance mode. The Auto Balance mode terminates balancing functions when a charge transfer value specified by the host microcontroller has been met. Note: Cell balancing requires the removal of the MCB_PS3_Z multicell power supply test board and attachment of cell devices that are capable of sourcing and sinking current.

The ISL78600 communicates to a host microcontroller through an SPI interface and to other ISL78600 devices using a robust, two-wire daisy chain system. The primary evaluation board provides configuration options that can be set using switches. These are discussed in detail later in this document.

Connecting multiple Renesas boards allows you to set up communications and measurement capability of many packs and up to 185 battery cells. However, you should review the [“Quick Hardware Setup Guide” on page 5](#). There are safety concerns as voltage levels increase with multiple packs.

2.1 Software Installation

This version of software supports ISL94212, ISL78600, or ISL78610 devices. (For ISL78610 devices, use the ISL78600 setting.) The software has been tested on XP, Win7, and Win8 platforms.

1. Run the *Renesas_ISL786XX_Installer_V301.exe* file. This installs the BMS GUI software to the PC. Depending on your IT department, there are a couple of items to address when performing an installation. Select **Run As Administrator** option when available. Click **Next** to continue and accept the license agreement.

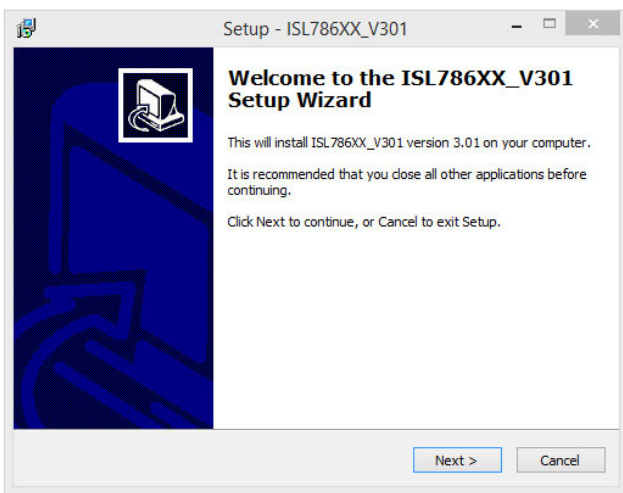

Figure 2. Setup Wizard

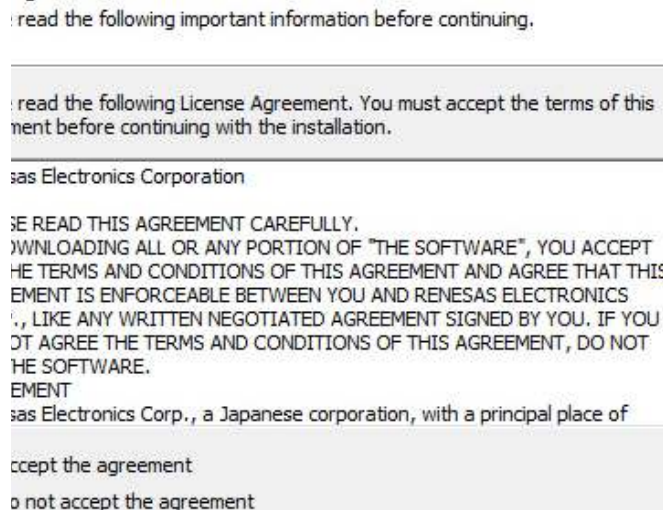

Figure 3. License Agreement

- When setting up the project installation and shortcut paths, to avoid issues with saving to the Programs directory, consider using Users\Public instead of the Programs directory.

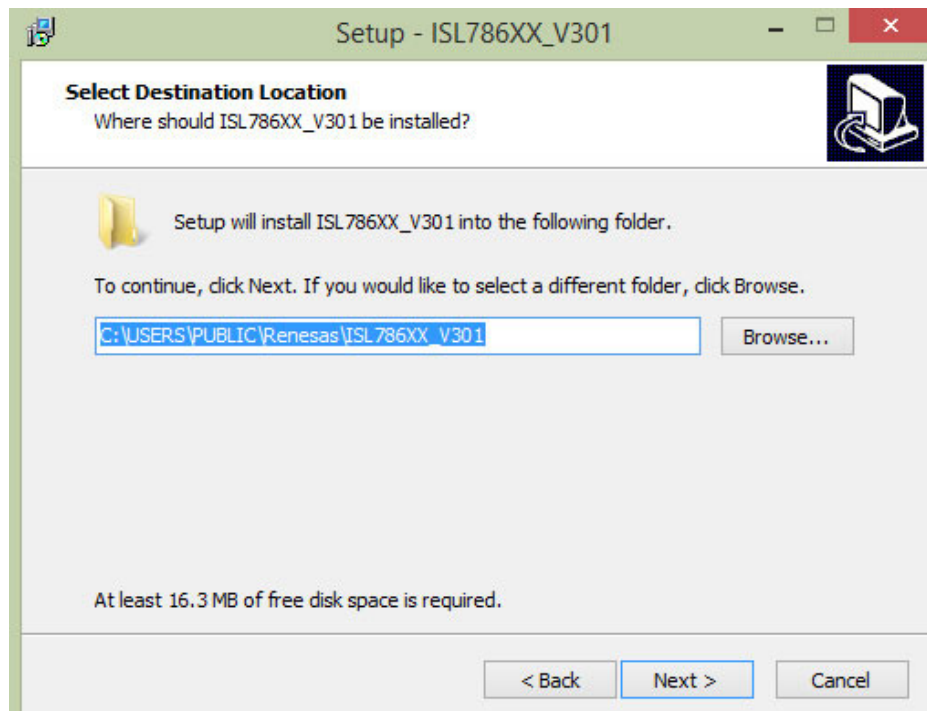

Figure 4. Setup Destination Location

- Connecting the evaluation board results in an automatic USB enumeration under the Human Interface section of the Windows device manager.

2.2 Quick Hardware Setup Guide

2.2.1 Single Board

Complete the following steps to ensure proper setup for a single board configuration.

- Before connecting the power supply to the boards, set the power supply voltage to 39.6V (3.3V per cell). If there are fewer cells being tested, reduce the power supply voltage such that it equals 3.3V times the number of cells.
- Connect and check the power supply to the MCB_PS3_Z board. The positive terminal is J₅/J₁₁ and the negative terminal is J₈/J₁₂. Check that the voltages on the J₂ connector are 3.3V from pin to pin. Ground should be on the pin labeled “0” and “G”. If there is no voltage on J₂, check that the switches are all set to “ON”. Also, make sure that there is a jumper on JP₂ of the MCB_PS3_Z board to select the 12 cell option. This puts the proper voltage on the VBAT pin.
- Turn off the power to the power supply.
- Connect ISL78600EVAL2Z connector J₄ to the MCB_PS3_Z board connector J₁.
- Check the jumpers and switches. Because this is a single board configuration, configure the ISL78600EVAL2Z board as follows:
 - EN, LEDEN should contain jumpers.
 - EN should be set to ENABLE.
 - Place a shunt on the TOP jumper for single board operation.
- Connect the microcontroller board (ISL78MICROEVZ) connector JP₁ to the ISL78600EVAL2Z board connector JP₆ (see [Figure 5 on page 6](#)).

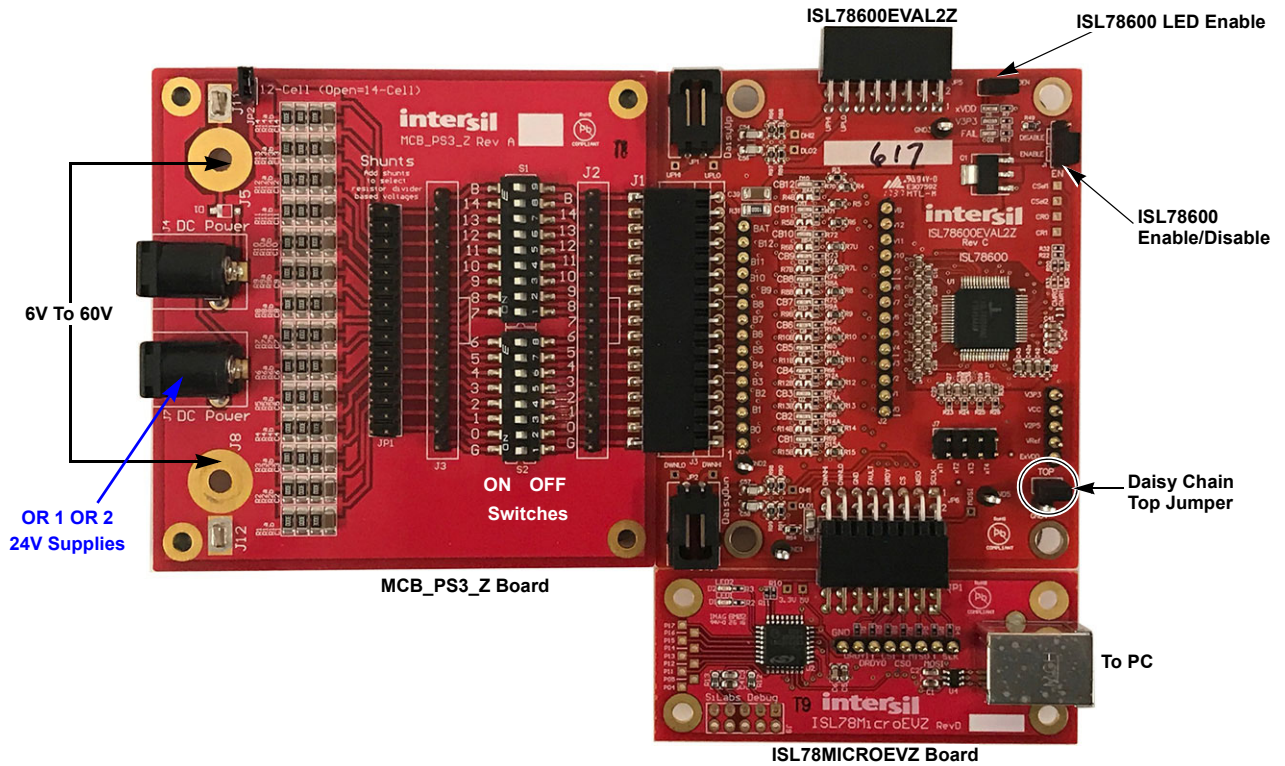

Figure 5. ISL78600EVKIT1Z Rev C Single Board Setup

7. Connect the USB port of the PC to the USB port of the ISL78600EVAL2Z board.
8. Run the GUI. A Startup screen in the GUI indicates whether the USB dongle is connected and waits for you to select the Evaluation board.

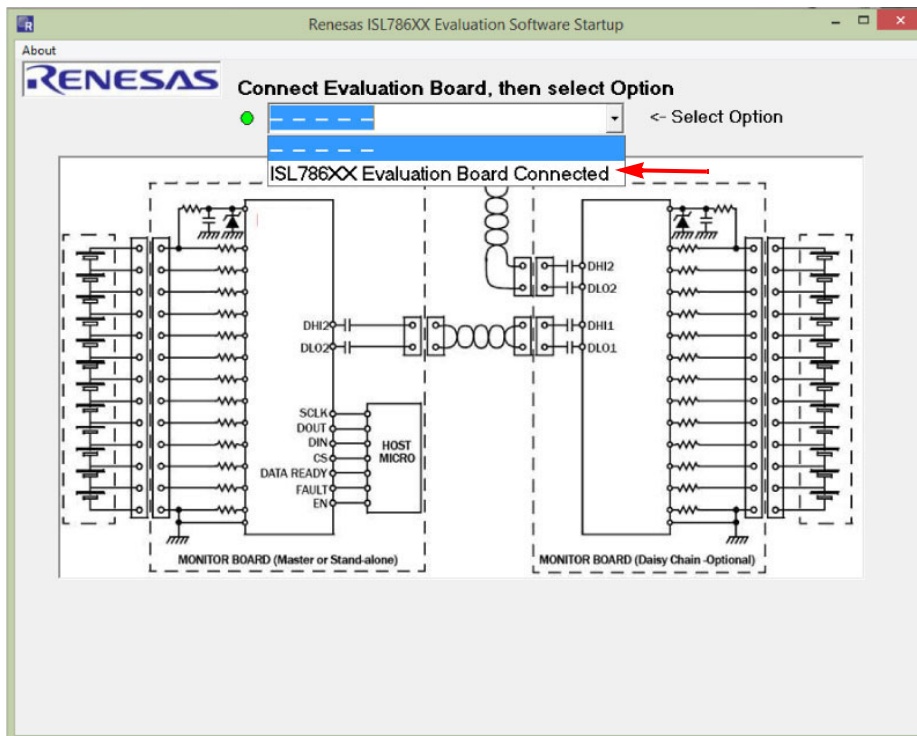

Figure 6. Startup Screen

9. Turn on the power to the supply and notice that there are two green LEDs (xVDD and V3P3), indicating the LDO regulators on the ISL78600 are operating.
10. When powered, the ISL78600EVAL2Z board voltages at various points should be:
 - a. V3P3 = 3.3V \pm 3%
 - b. VCC = \sim 3.3V \pm 5% (a little lower than V3P3)
 - c. V2P5 = 2.5V \pm 2%
 - d. VREF = 2.5005V \pm 0.5mV
11. Use the software to connect the board and read the cell voltages, see [“Quick GUI Setup Guide \(Using the GUI\)” on page 11](#).
12. On the GUI, select **Connect**. This brings up a configuration box. Select **Non-Daisy** and click on **OK**.
13. Compare the voltages at the board input with the readings provided by the GUI. Use a meter to measure each of the cell voltages just after the J₃ connector on the ISL78600EVAL2Z board, because the MCB_PS3_Z board may not accurately divide the voltages into equal 3.3V steps. Also, measure the voltage from cell-to-cell, not cell-to-ground, to get the best accuracy. The meter reading and the GUI readout voltages should closely match (\pm 2.5mV at 3.3V and room temperature).

2.2.2 Daisy Chain

Complete the following steps to ensure proper setup for a daisy chain configuration.

1. Before connecting the power supply to the boards, set the power supply voltage to 39.6V (3.3V per cell). If there are fewer cells being tested, reduce the power supply voltage such that it equals 3.3V times the number of cells.)
2. Connect the power supply to all MCB_PS3_Z boards in parallel. This is not typical of a battery installation, where the ground of one board is the V_{BAT} of another, but it easily facilitates testing of the communication and allows a safer environment for initial testing.
There should be one MCB_PS3_Z board for every evaluation board. The positive terminal of the MCB_PS3_Z board is J₅/J₁₁ and the negative terminal is J₈/J₁₂. Check that the voltages on the J₃ connectors of all boards are 3.3V from pin to pin. Ground should be on the pin labeled “0” or “GND”.



USE CAUTION when connecting the MCB_PS3_Z boards in series, since voltages quickly reach hazardous levels. **BE CAREFUL!**

3. Turn off the power to the power supply.
4. Connect each ISL78600EVAL2Z board connector J₄ to an MCB_PS3_Z board connector J₁.
5. Connect the daisy chain. The daisy chain can be connected together directly or with cables, as shown in [Figures 7 and 8 on page 10](#), or using a combination of direct and cable connections. When using twisted pair cables, connect the wires as shown in [Table 1](#). (Note: The boards are configured to prevent both direct connection and twisted pair cable connection.)

Table 1. Daisy Chain Connection

Daisy Chain Board	ISL78600 DaisyDwn	ISL78600 DaisyUp
Master	NC	Connect to DaisyDwn of board above
Middle	Connect to DaisyUp of board below	Connect to DaisyDwn of board above
Top	Connect to DaisyUp of board below	NC

Note: NC = No connection

6. Check the jumpers and switches on the boards. Because this is a daisy chain configuration, configure each board as follows:
 - a. EN and LEDEN contain jumpers.
 - b. EN should be set to ENABLE.
 - c. Place a shunt on the TOP jumper on the top daisy chain board only. There should not be a shunt on the TOP jumper on the other two boards.
7. Connect the microcontroller board (ISL78MICROEVZ) connector JP₁ to the master ISL78600EVAL2Z board connector JP₆.
8. Connect the USB port of the PC to the USB port of the ISL78MICROEVZ daisy chain master board.
9. Turn on the power to the supply and notice that on each board there are two green LEDs (xVDD and V3P3), indicating the LDO regulators on the ISL78600 are operating.
10. When powered, the ISL78600 voltages at various points (relative to the ground on the board) should be:
 - a. VDD = 3.3V ±3%
 - b. VCC = ~3.3V ±5% (a little lower than VDD)
 - c. V2P5 = 2.5V ±2%
 - d. VREF = 2.5005V ±0.5mV
11. To connect all boards, complete the following. Specify **Daisy Chain** and the number of devices in the chain when the configuration screen appears.
12. On the GUI, select **Connect**. This brings up a configuration box. Select **Daisy Chain** and the number of daisy chain connected boards. Then click on **OK**.
13. See ["Quick GUI Setup Guide \(Using the GUI\)" on page 11](#). Use the software to read the cell voltages.
14. Compare the voltages at the board input with the readings provided by the GUI. Use a meter to measure the voltages after the J₃ connector on the ISL78600EVAL2Z boards, because the MCB_PS3_Z board may not accurately divide the voltages into equal 3.3V steps. Measure the voltage from cell to cell, not cell to ground, to get the best accuracy. The meter reading and the GUI readout voltages should closely match (±2.5mV at 3.3V and room temperature).

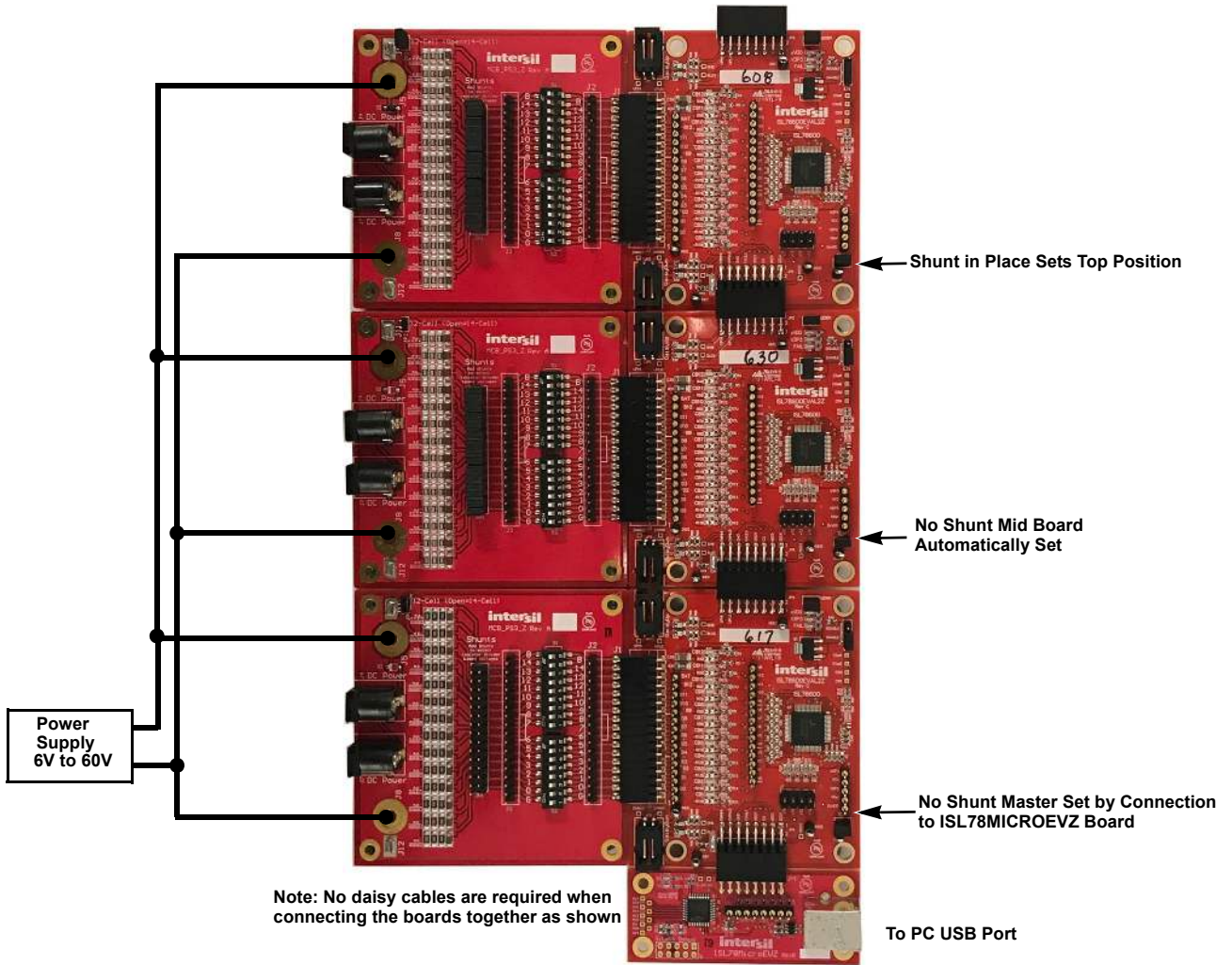

Figure 7. ISL78600EVKIT1Z Rev C in 36-Cell Direct Connect Daisy Chain Configuration

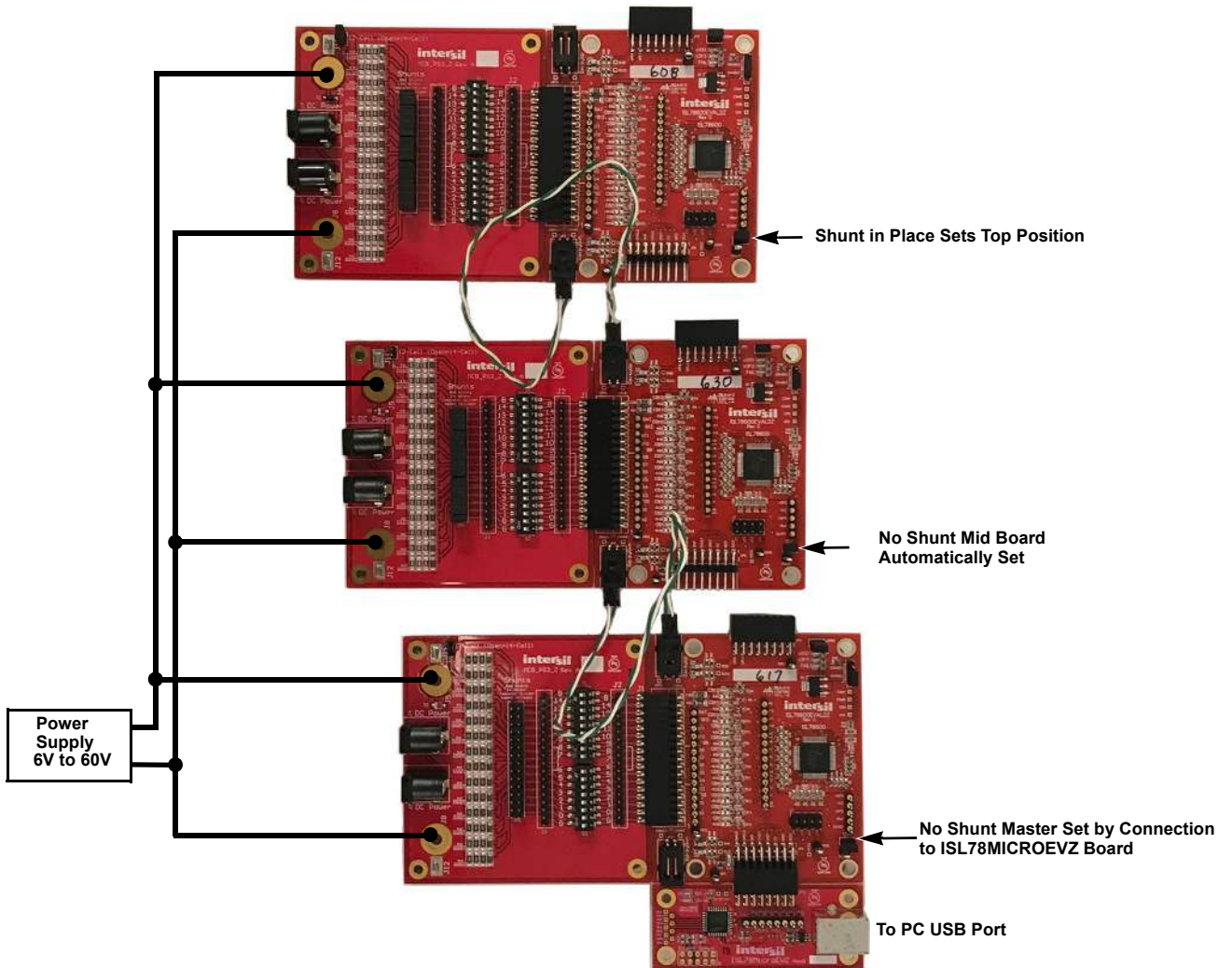

Figure 8. ISL78600EVKIT1Z Rev C in 36-Cell Cable Connect Daisy Chain Configuration

2.3 Quick GUI Setup Guide (Using the GUI)

Complete the following steps to setup and use the GUI.

1. When the board is powered up and connected to the PC through the USB cable, start the GUI program.
2. A Startup screen in the GUI waits for you to select the combo box. Click on **BMS Evaluation Board Connected**.

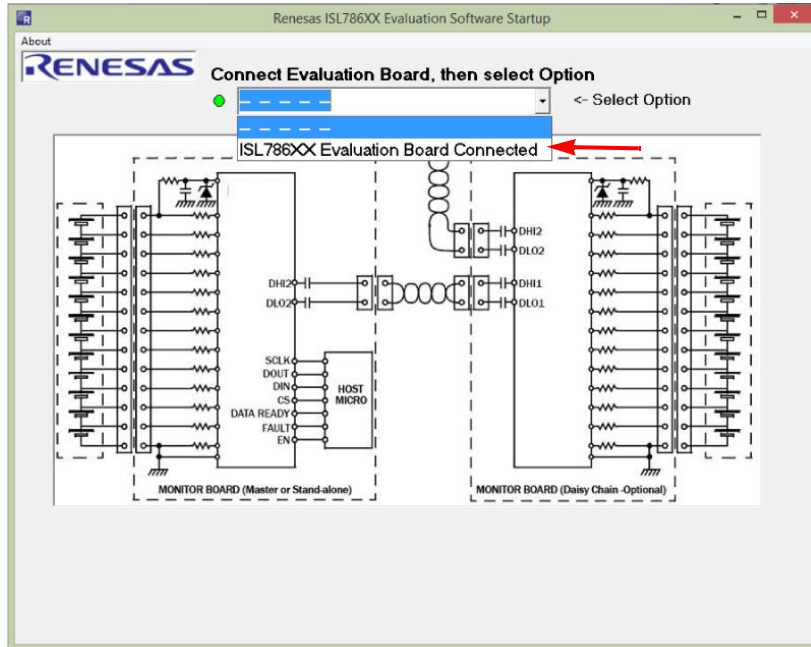

Figure 9. Startup Screen

3. Open the ISL78600 GUI software. From the Startup screen, the software takes you to the Configuration Screen (see Figure 10). For a stand-alone configuration, select **Non-Daisy Chain** in the BMS Configuration box, then click **OK**. For a daisy chain configuration, select **Daisy Chain** in the BMS Configuration box and select the number of devices in the daisy chain, then click **OK**. The GUI returns to the main screen and automatically connects to the system.

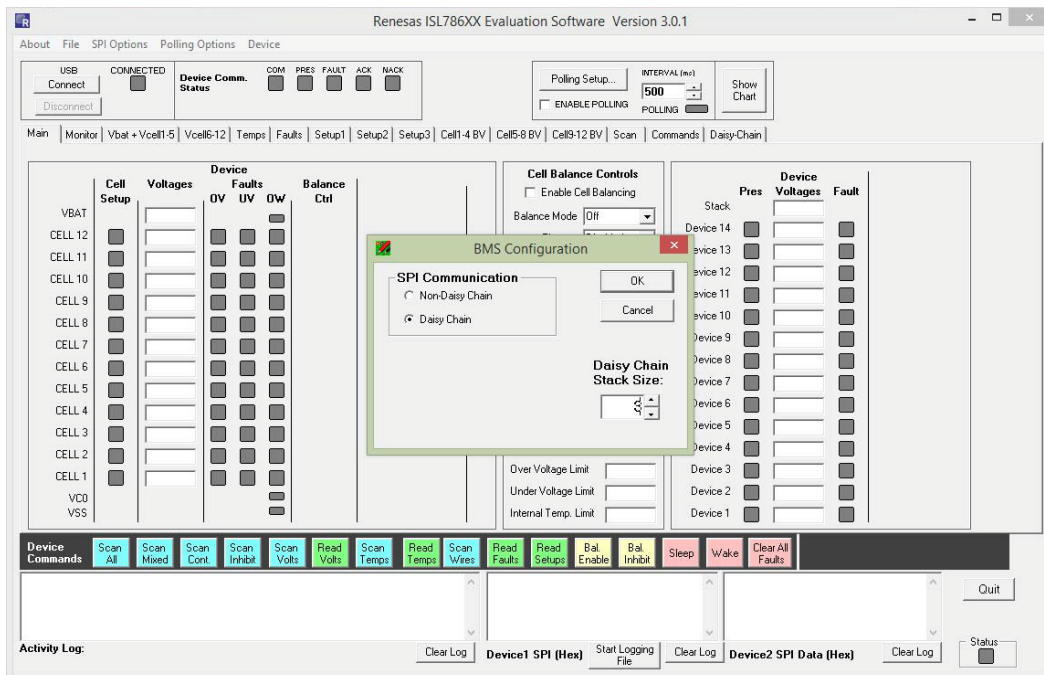

Figure 10. GUI Configuration Select

4. In a daisy chain configuration, the top bar provides an indication of the boards connected and allows selection of any specific device in the daisy chain. Device 15 selects all devices. Device 0 selects devices that are not yet identified. For a single board, these boxes are not shown.
5. Use the various tabs and buttons to monitor and control the operation of the device.
6. The **Device Commands** buttons along the bottom of the main tab are commands sent to all boards in the system. So, selecting **Scan Volts** then **Read Volts** causes all boards to read the cell voltages and temperatures and update the ISL78600 register values and the GUI display boxes. (Note: These buttons send separate commands to each board. It does not send a Scan All or Read All command), see [Figure 11](#).
7. At the bottom of the screen are activity logs showing the USB communications and the SPI communications to the Master board.
8. To clear fault indications, read the register, click on each individual bit to change the setting (or write 0 to the register value), and click on **Write** to send the value to the device. Using the **Read Group** or **Write Group** button sends commands to all registers on the page.
9. Use the **Show Chart** button to view various voltages and status in real time (see [Figure 12 on page 13](#)).

2.3.1 Main Window

The Main window (See [Figure 11](#)) of the GUI provides an overview of the various voltages in the battery pack. The voltages and associated fault indicators shown on the left and the temperature values and limits in the middle reflect results of voltage and temperature scans for the device selected in the Select Daisy Chain Device Number box.

To update the values in the window, click on **Scan Voltages** and/or **Scan Temps** in the Device Commands row at the bottom of the screen. Next, click on **Read Volts** and/or **Read Temps** buttons.

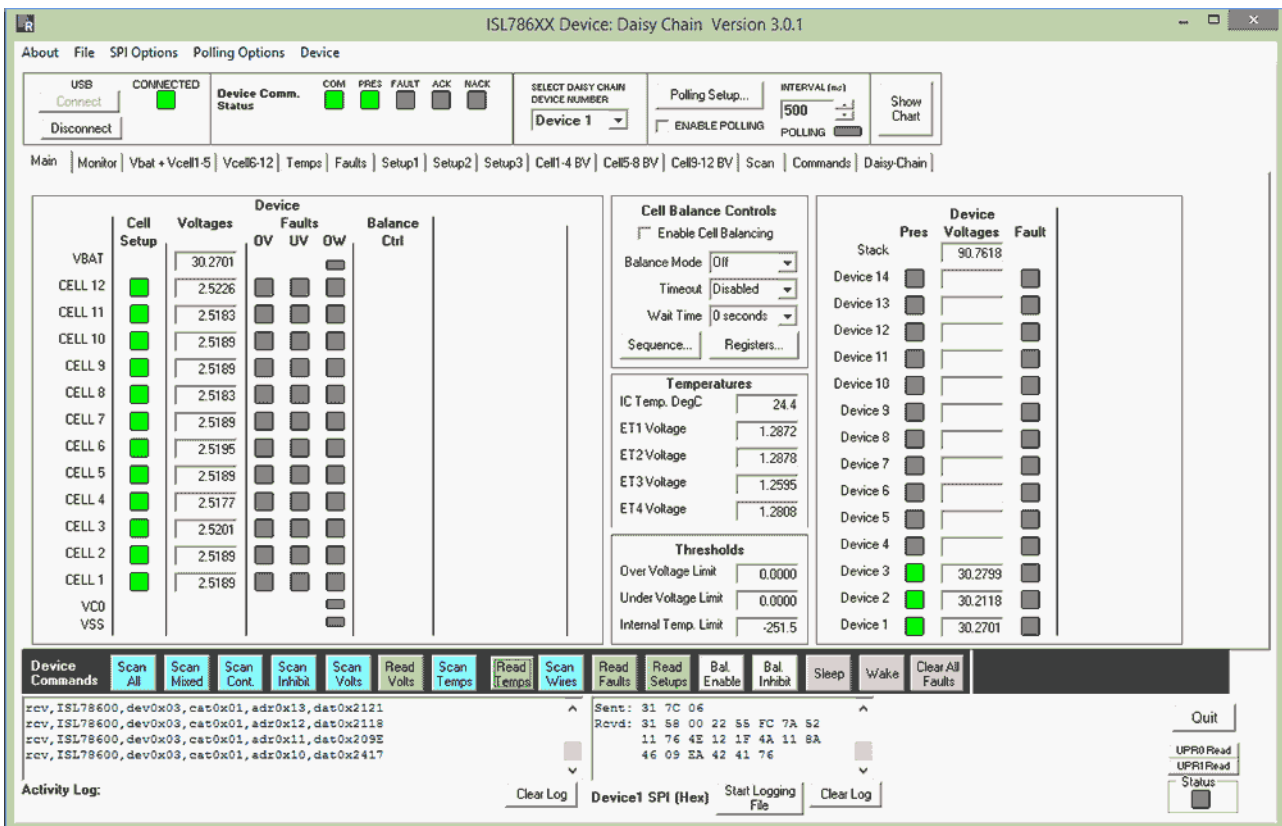

Figure 11. Main GUI Window - Three Cascaded Devices

2.3.2 Chart Window

The charting function of the GUI provides real-time viewing of the critical voltages in the battery pack. The chart updates results as long as the GUI is polling. If the GUI stops polling (or there is a communication interruption), the chart maintains the last valid value.

At the end of a sample period, the captured data can be exported to a file, which can be loaded into Excel for further analysis by clicking on the **Export** button.

Using the controls at the left of the screen, various charts can be turned off, and the specific cells being monitored can be chosen. At this time, the cell voltages of only two boards can be monitored on one screen, and only the temperatures of Board 1 can be monitored.

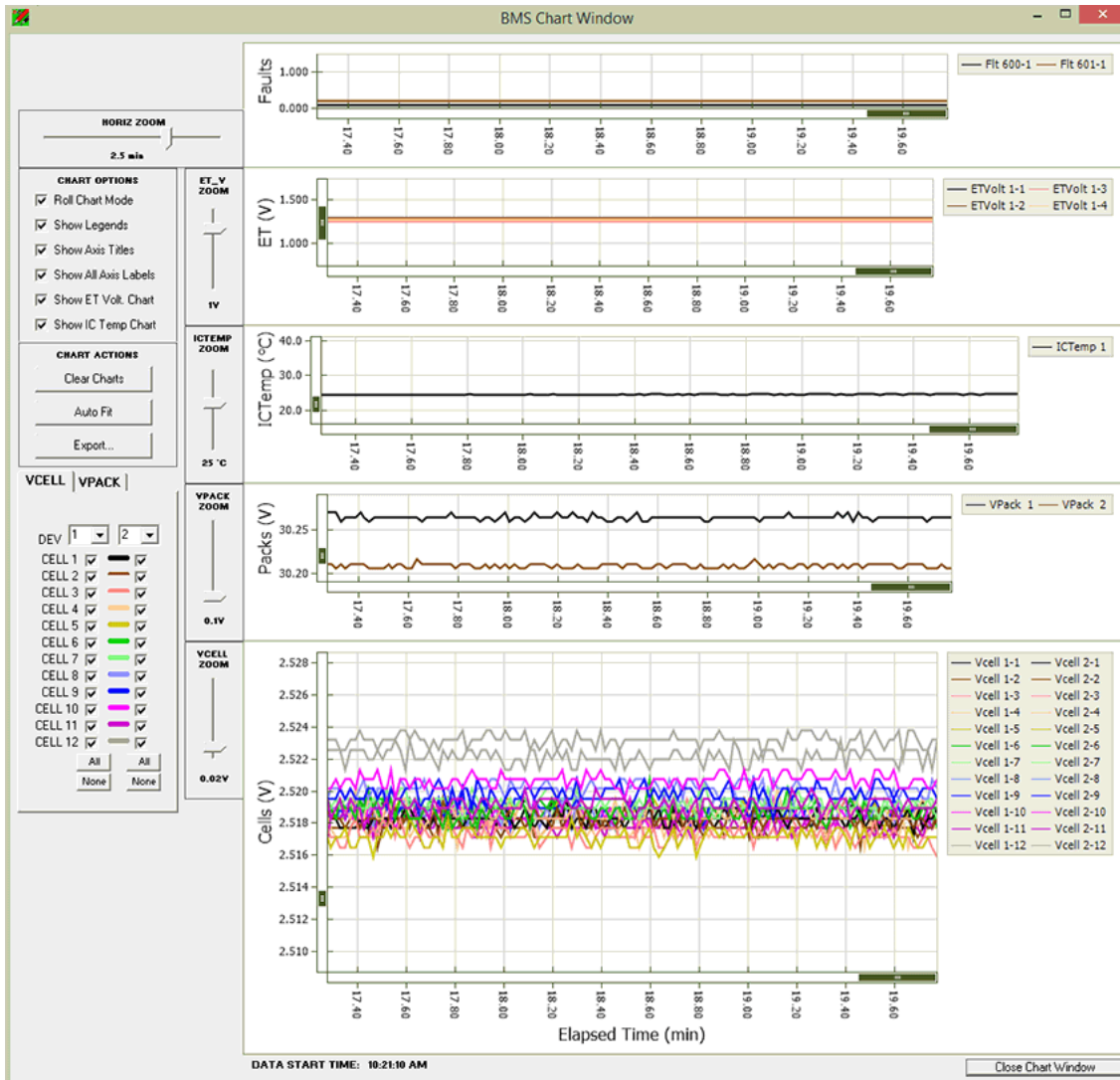

Figure 12. Chart Window

2.3.3 Monitor Tab

The Monitor tab shows the voltages and status of the first four boards in the daisy chain. At this time, it is not possible to select the results for any other boards in the stack. Individual boards can be monitored in the Main window, one board at a time.

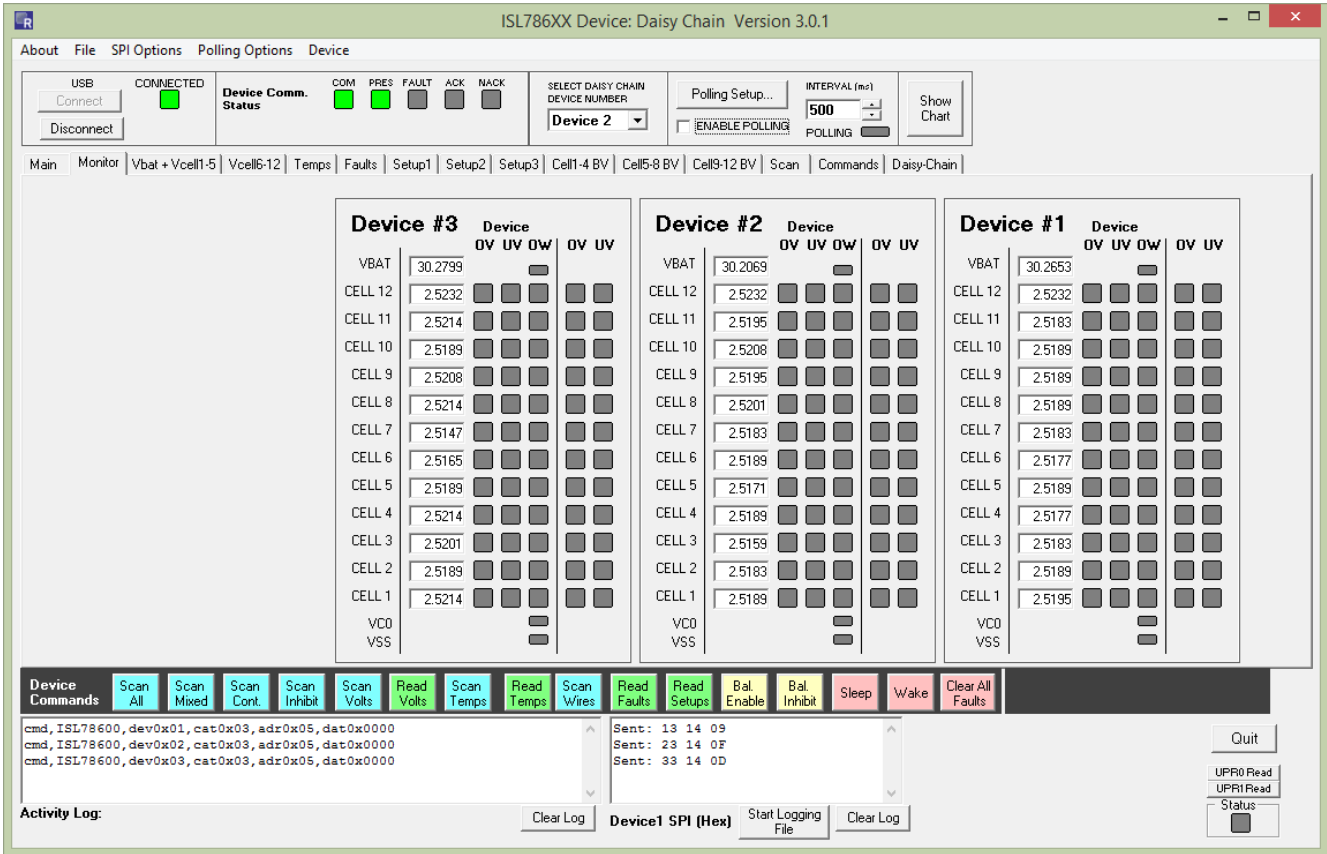

Figure 13. Monitor Tab

2.3.4 Fault Tab

The Fault tab shows the status of the fault register of the selected device. To update the display, click on the individual **Read** buttons at the end of each fault register, or click on the **Read Group** button on the Device Command line (toward the bottom of the window) to read all registers in the Tab.

To clear a bit, click on the bit that is set (or write a 0 in the box at the right to reset all bits.) Next, click on the **Write** button at the end of each fault register, or click on the **Write Group** button on the Device Command line to write to all of the registers in the Tab.

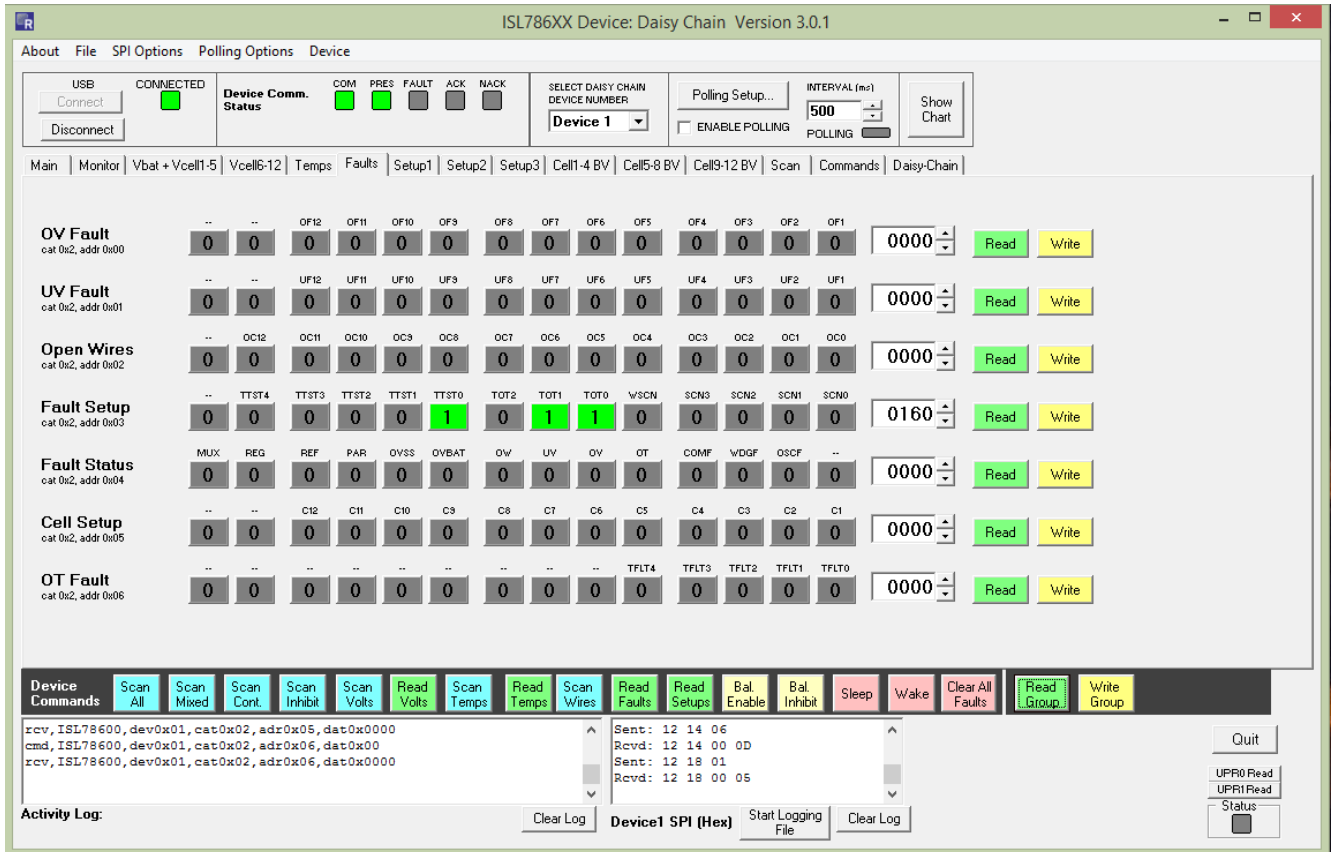

Figure 14. Fault Registers

2.3.5 Command Tab

The Command tab allows individual commands to be sent to any device in the stack (or all devices, if Device 15 is chosen.) This Tab includes a Raw Message Sender and CRC4 calculator. By entering in the Device Address, Data Type, Data Address, and Data the GUI calculates the CRC4 value and shows the resulting Encoded command. This command can then be sent to the chosen device. The image in [Figure 15](#) shows the command for SLEEP.

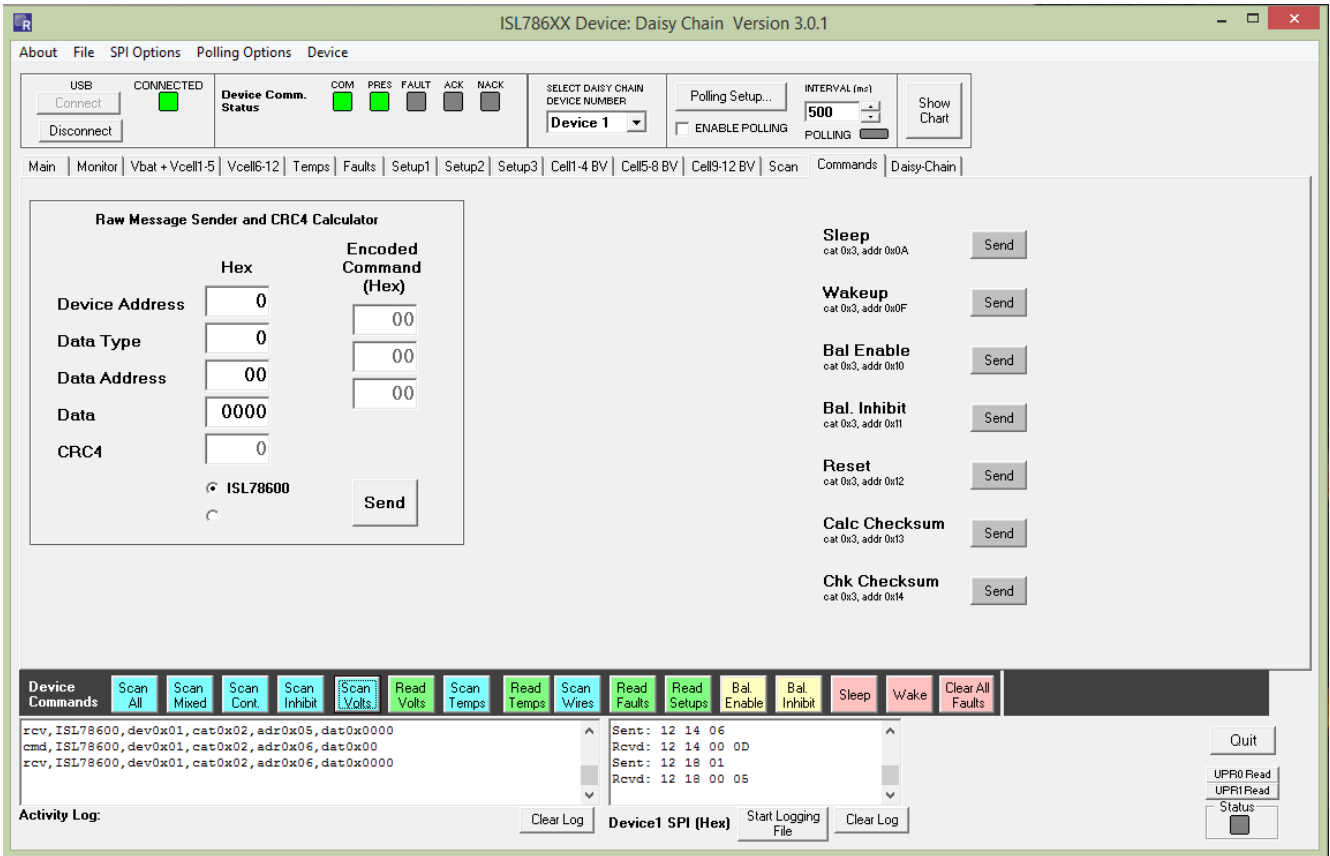

Figure 15. Commands

3. PCB Layout Guidelines

In [Figures 19](#) and [20](#) (battery connection circuits), the first stage of the input filter provides protection against transients and EMI for the cell inputs. They carry the loop currents produced by EMI and should be placed as close to the connector as possible. The ground terminals of the capacitors must be connected directly to a solid ground plane. Do not use vias to connect these capacitors to the input signal path or to ground. Place any vias in line to the signal inputs so that the inductance of these forms a low-pass filter with the grounded capacitors.

In [Figure 21 on page 23](#), the daisy chain components are shown to the top right of the drawing. They are split into two sections. Place the components to the right of this section close to the board connector with the ground terminals of capacitors connected directly to a solid ground plane. This is the same ground plane that serves the cell inputs. Place the components to the left of this section as close to the device as possible.

Place the battery connector and daisy chain connectors close to each other on the same edge of the board to minimize any loop current area.

Two grounds are identified on the circuit diagram. They are referred to as noisy and quiet grounds. The noisy ground, denoted by an “earth” symbol, carries the EMI loop currents and digital ground currents. The quiet ground defines the decoupling voltage for voltage reference and the analog power supply rail. Join the quiet and noisy grounds at the VSS pin. Keep the quiet ground area as small as possible.

The circuits shown at the bottom of [Figure 18 on page 20](#) provide external temperature inputs. These inputs are designed to operate with on-board NTC thermistors. If external thermistors are desired, either remove the on-board thermistors or replace them with 10k resistors.

Each of the external inputs has an internal pull-up resistor, which is connected by a switch to the VCC pin whenever the TEMPREG output is active. This arrangement results in an open input being pulled up to the V_{CC} voltage.

3.1 Component Selection

Certain failures associated with external components can lead to unsafe conditions in electronic modules. A good example of this is a component that is connected between high energy signal sources failing short. Such a condition can easily lead to the component overheating and damaging the board and other components in its proximity.

One area to consider with the external circuits on the ISL78600 is the capacitors connected to the cell monitoring inputs. These capacitors are normally protected by the series protection resistors but could present a safety hazard in the event of a dual point fault where both the capacitor and associated series resistor fail short. Also, a short in one of these capacitors would dissipate the charge in the battery cell if left uncorrected for an extended period of time. Renesas recommends that input capacitors connecting directly to ground are fail-safe or open mode types. An alternative strategy is to replace each of these capacitors with two devices in series, each with double the value of the single capacitor.

A dual point failure in the balancing resistors of [Figure 19 on page 21](#) and associated balancing MOSFET could also give rise to a shorted cell condition. Renesas recommends that the balancing resistor is replaced by two resistors in series.

The layout of the ISL78600EVAL2Z board attempts to accomplish the following:

- Minimize the placement of signals on inner layers that might exceed the voltage limits on the board. Specifically, these include the daisy chain signals on the cable side of the isolation capacitors. Inner layers do not have as much isolation as external layers.
- Minimize the placement on outer layers, the traces carrying signals to and from the ISL78600. This minimizes the effects of radiation-induced voltages on board circuitry.
- Minimize the effect of temperature-induced stress on the IC during flow solder using the absence of a ground plane on the top layer under the IC. However, a middle and bottom layer do contain ground layers to protect the circuits on the board from radiation-induced voltages.

- Allow extra space around the daisy chain signals that might experience higher voltages when the boards are cascaded.

3.2 Evaluation Board Design Details

In the ISL78600EVKIT1Z evaluation kit:

- The microcontroller board is split from the evaluation board. The microcontroller board is designed to automatically select the board connected to it as the master. To do this, the mode select bits CMS1 and CMS2 on the ISL78600EVAL2Z board are pulled up to local V3P3 voltages; therefore, automatically setting them as middle devices (absent any other connection). When an evaluation board connects to the microcontroller board, CMS1 is pulled low through the connector making this evaluation board the Master. The top device is selected by placing a shunt on the TOP jumper, which pulls CMS2 low. This configuration eliminates the switches in the original design. If the system uses an external controller, it is easier to eliminate the Renesas microcontroller. But, when connecting an external microcontroller, remember to connect together Pins 11 and 12 of the ISL78600EVAL2Z board JP₆ connector. This arrangement allows for a smaller evaluation board form factor.
- The CMR1 and CMR0 input are set to “1” by on-board resistors. These set the daisy chain speed to 500kHz. If slower speeds are desired, these resistors need to change. Remember that changing daisy speeds requires changes to the capacitors in the daisy chain link. To switch to slower daisy chain speeds, check the datasheet for changes to the daisy chain capacitor values for the selected changes to the CMR resistors. These changes require removal and replacement of soldered components on the PCB.
- Daisy chain operation can be set with direct board-to-board connection of the daisy chain or with daisy chain cables. These connections use the same circuits.
- The external MCB_PS3_Z board has power switches. These can be used to experiment with open wire conditions.
- The power supply board (MCB_PS3_Z) to evaluation board connection provides direct connection to the ISL78600EVAL12Z board without a cable. If a cable connection between the evaluation board and a battery stack is desired, remove the J₃ connector on the evaluation board and replace it with a different type. One recommended option for cable connection components is shown as follows:
 - Vendor: TE connectivity
 - PCB connector part number: 6-104935-6
 - Mates to cable connector part number: 1-104257-6
 - Cable connector pins part number: 1-104480-7
 - Cable wire: 3M 8124 series
- The MCB_PS3_Z board was designed to allow connection of two 24V regulators. When two regulators connect, the evaluation board is powered by 48V. The connectors used have a “break-before-make” configuration, so removing or adding a second supply causes a power reset.
- If this board is to be used with an external power supply at a voltage greater than 40V and at temperatures higher than 60°C, remove the diode. It cannot handle reverse voltage differential at these higher temperatures.
- In the default configuration, the board monitors the cells after the cell balance resistor.
- In this default condition, turning on a cell balance input pulls the input voltage low, so monitoring that input returns near 0V. This is the preferred configuration for safety coverage, because the system can check this voltage to confirm that the input circuit and cell balance components are working correctly.
- When using the MCB_PS3_Z board, turning on a cell balance output also changes the voltage at the other cells, because the cell balance connects a 100Ω resistor in parallel with the MCB+PS3_Z boards 100Ω series divider resistor.
- If this is not the desired cell connection, the board can be modified to monitor the cells directly at the board input pins. This involves removing some resistors and adding others. To do this, remove resistors R_{4A} to R_{15A} (0Ω) and populate resistors R_{5B} to R_{15B} (100Ω).

- The ISL78600EVAL2Z board has a resistor divider and thermistors on the board for external temperature measurement. The resistor divider is set up for the specific Murata thermistor specified in the BOM. If it is desired to connect thermistors off board, remove thermistors (R₂₇ to R₃₀) or replace them with resistors equal in value to the external thermistors. Also, if the external thermistors differ in room temperature resistance, it might also be necessary to replace the upper resistor in the divider (R₂₃ to R₂₆) with more appropriate valued ones.
- If it is desired to use the EXTn inputs for monitoring a voltage, remove the on-board thermistors (R₂₇ to R₃₀) and the upper divider resistors (R₂₃ to R₂₆) and apply a voltage directly to the pins on J₇. Measurement happens in response to a Scan Temperatures command.

3.3 ISL78600EVAL2Z Evaluation Board

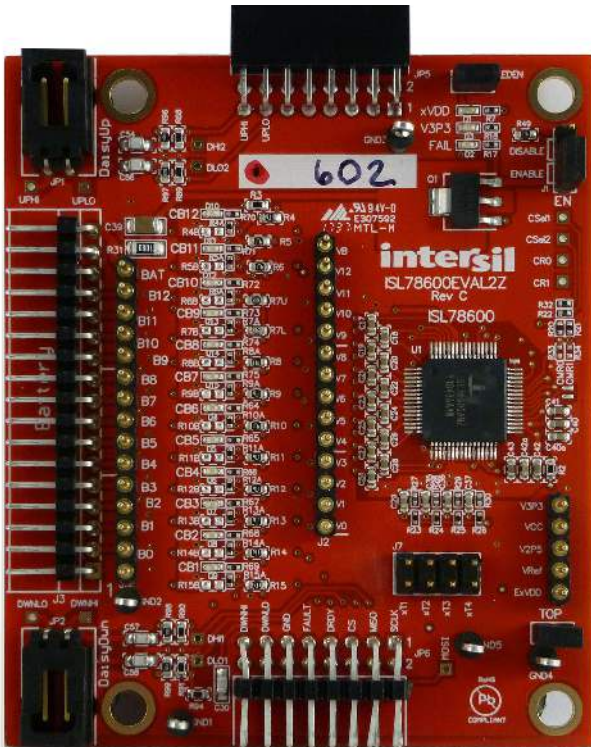

Figure 16. Top View

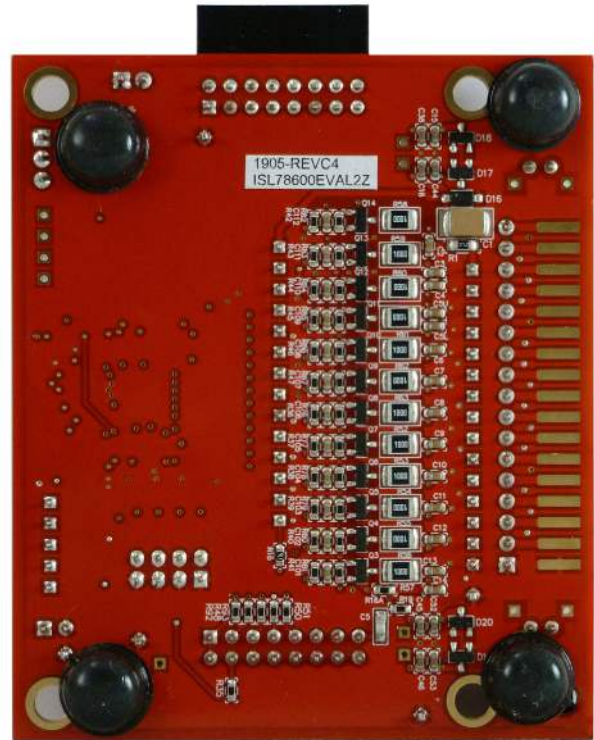

Figure 17. Bottom View

3.4 Schematics

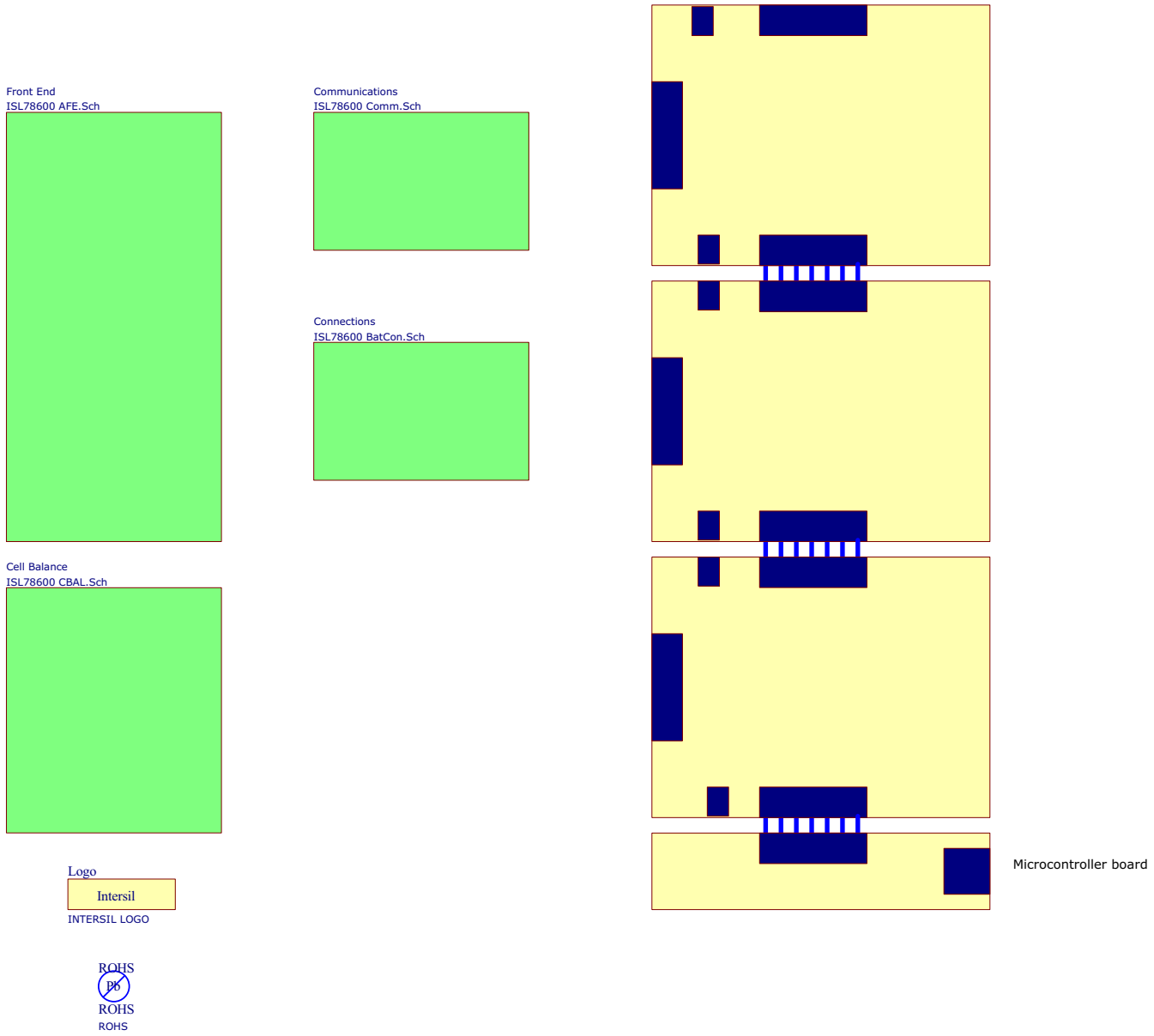
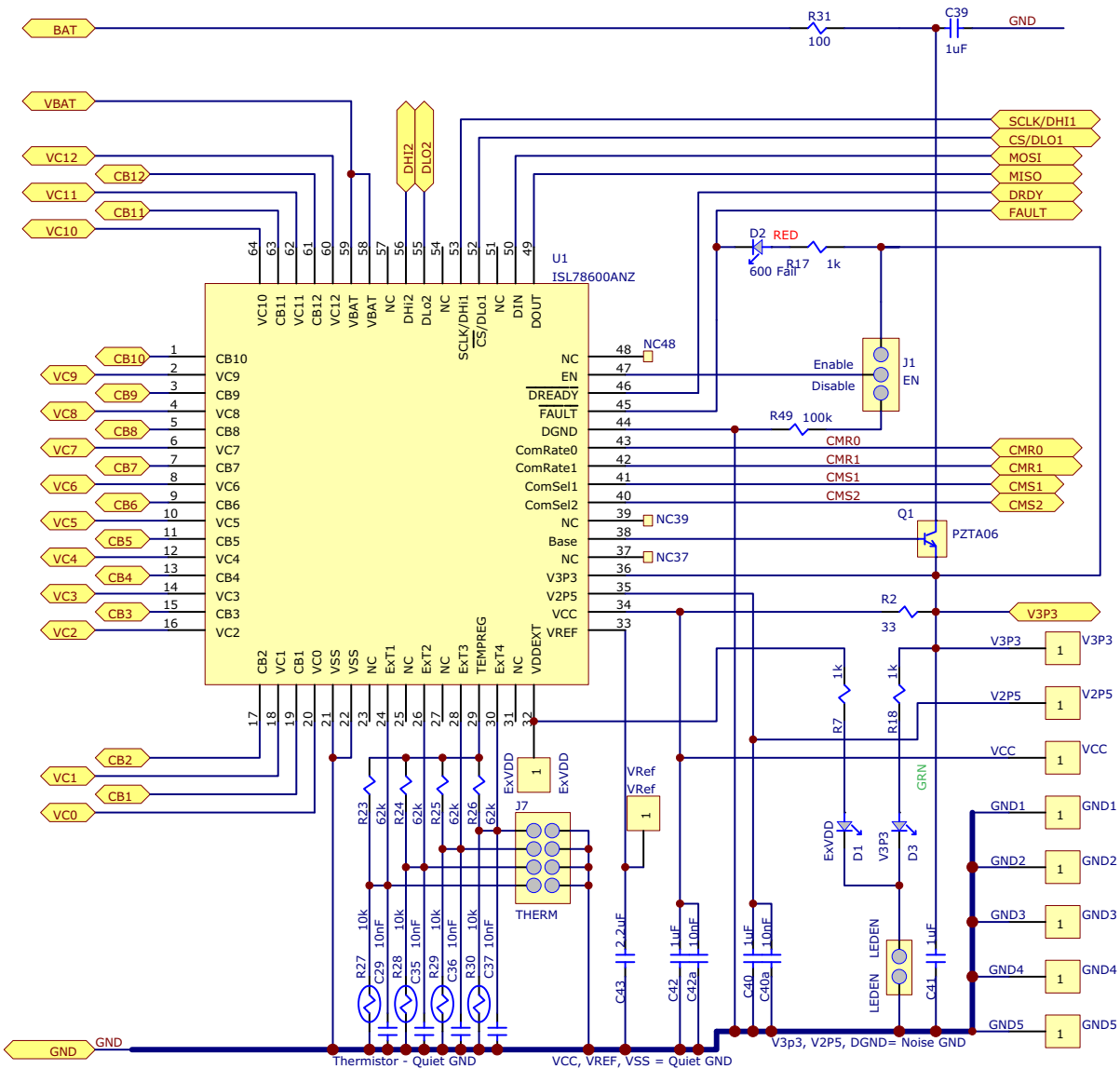

Figure 18. ISL78600EVAL2Z Rev C Board Block Diagram



Changes:
RevB: Added D1 LED and R7 on ExVDD
RevC: Added another ground point

Figure 19. ISL78600EVAL2Z Rev C Board AFE Schematic

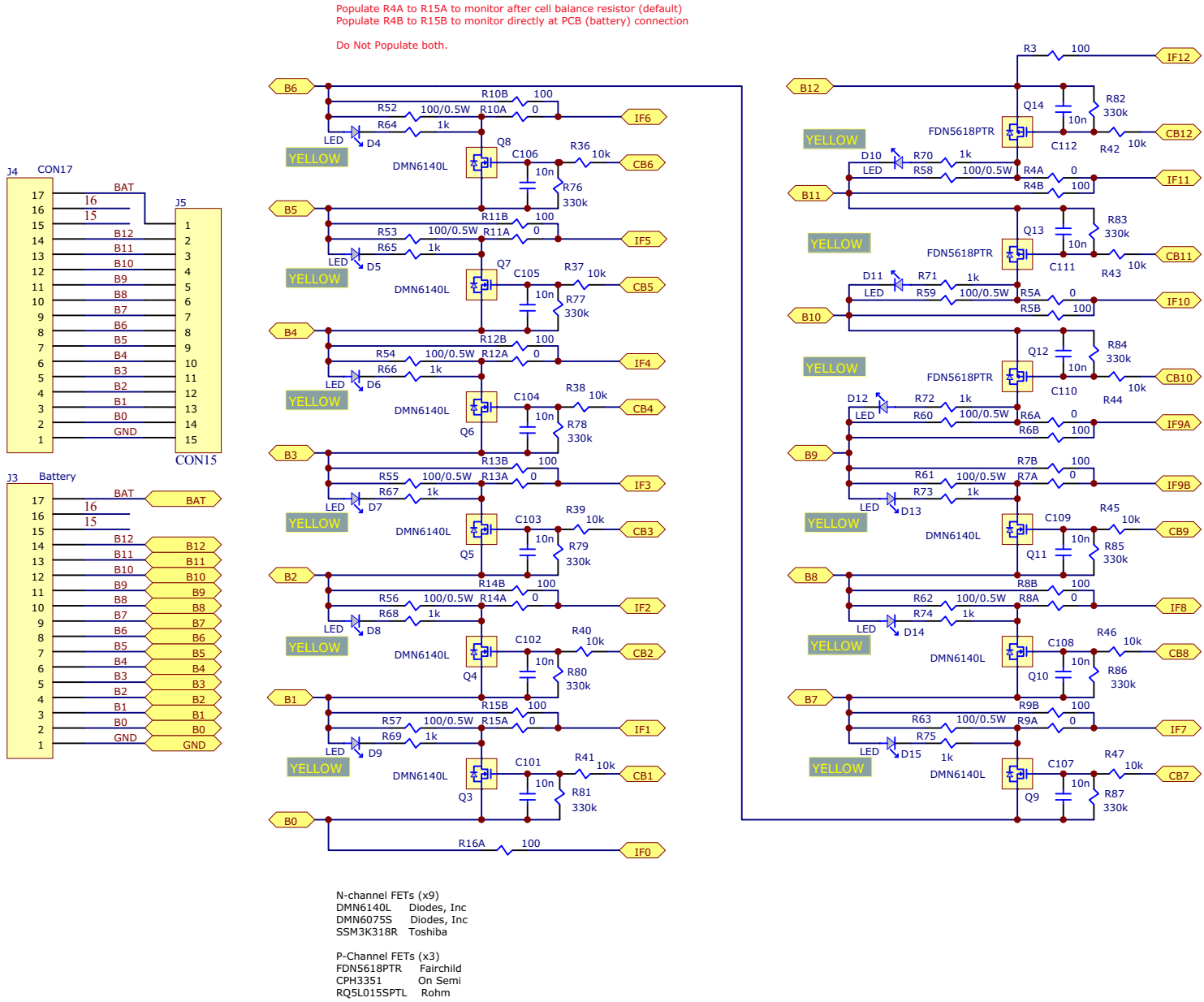

Figure 20. ISL78600EVAL2Z Rev C Board Cell Balance Schematic

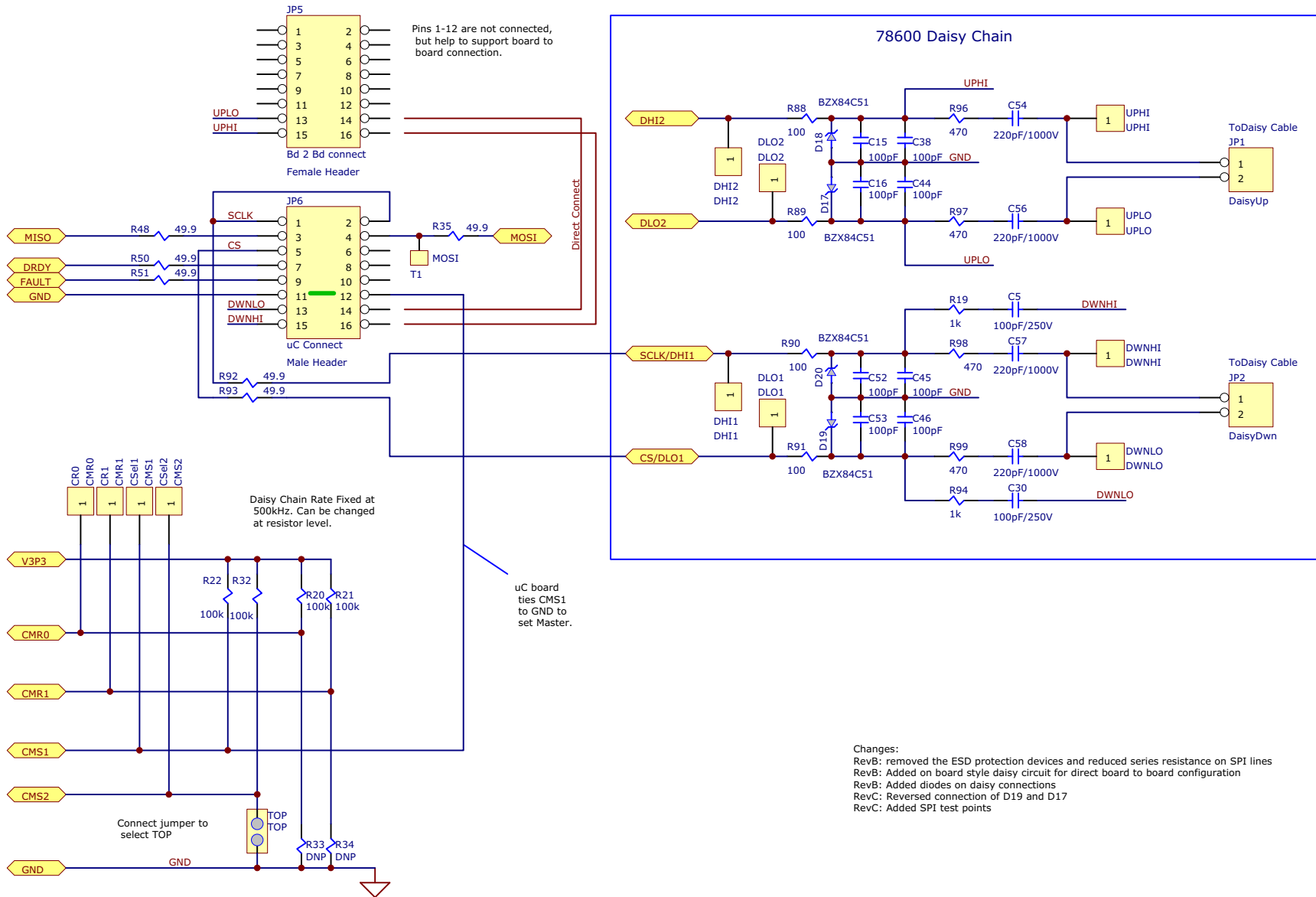
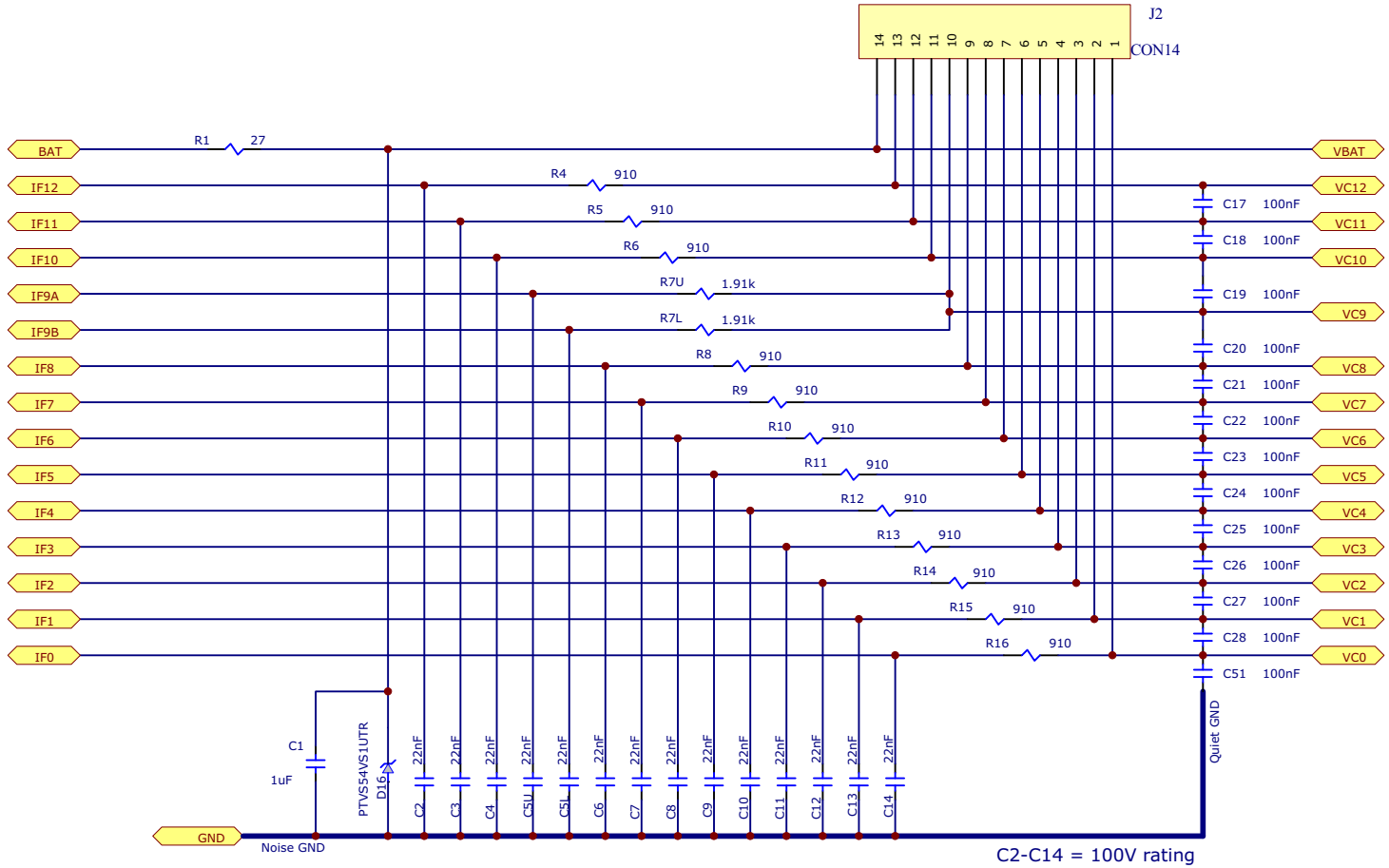

Figure 21. ISL78600EVAL2Z Board Communications Schematic



J3 = Sullins, P/N: STC02SYAN
Mates to PCB Socket, Sullins P/N: NPTC171LGBN-RC
or, Mates to cable connector, Molex P/N: 0050579017
or, Mates to cable connector, TE Connectivity P/N: 3-87499-2

J3 = TE Connectivity (R/A connector), P/N: 6-104935-6
Mates to cable connector: TE Connectivity P/N: 1-104257-6

Cable wire 3M 8124 Series
Cable Pins: TE Connectivity: P/N: 1-104480-7
Cable Pins: Molex: P/N: 0016020086

Changes:
Rev B:
Added C5U (previously missing)
Changed C5 to C5L

Figure 22. ISL78600EVAL2Z Board Battery Connection Schematic

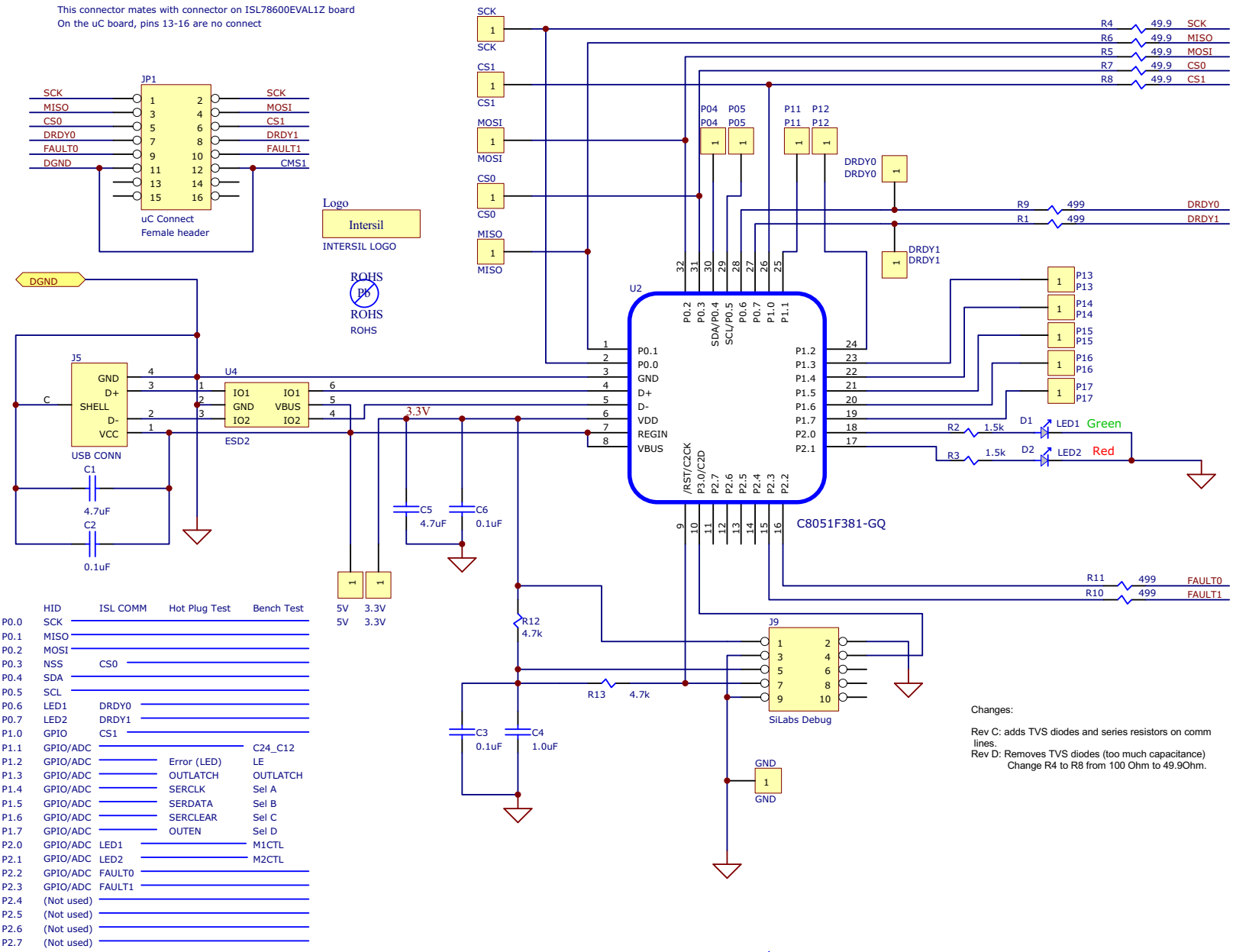

Figure 23. ISL78MICROEVZ REVD Microcontroller Schematic

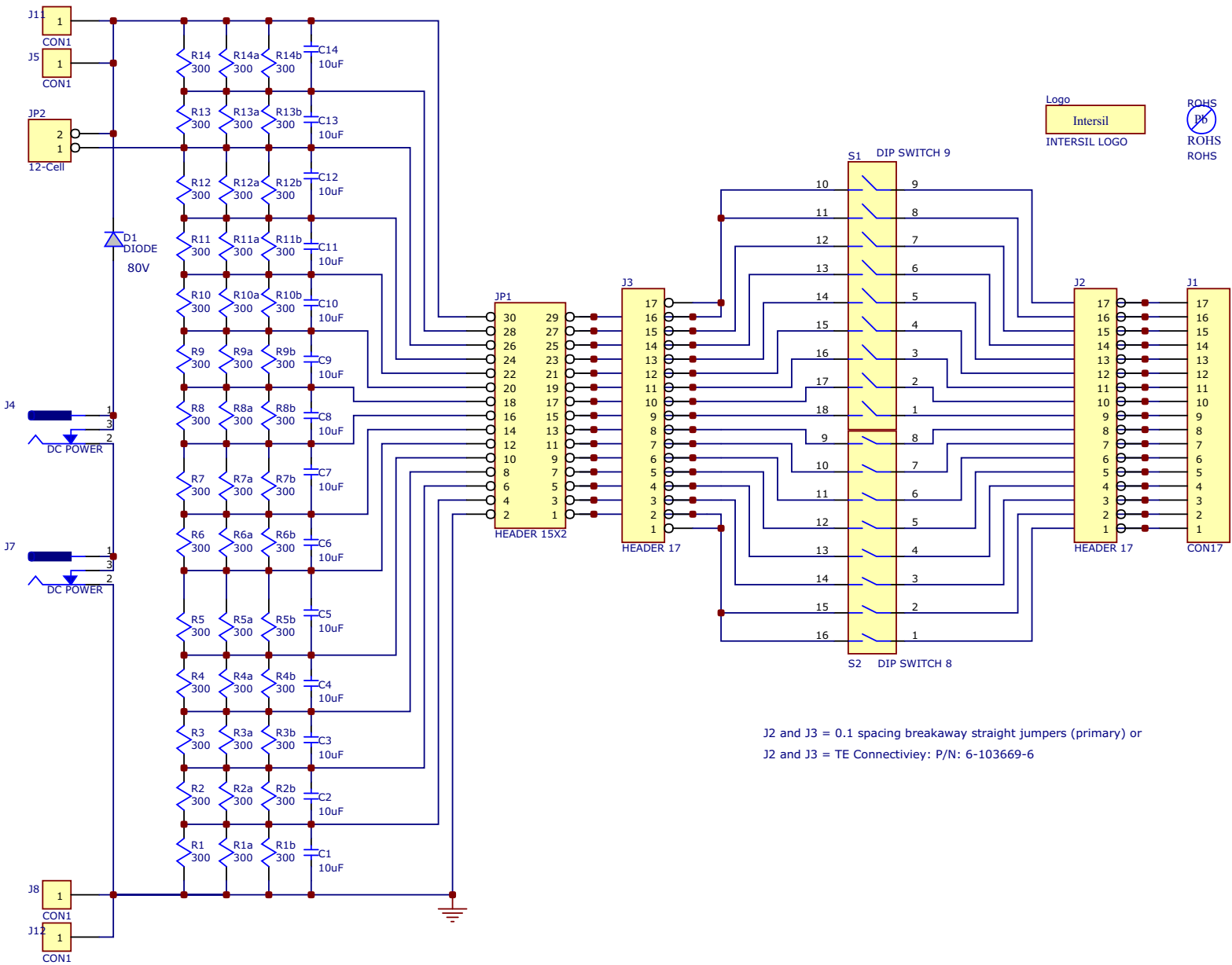

Figure 24. MCB_PS3_Z Power Supply Board Schematic

3.5 Bill of Materials

Qty	Reference Designator	Description	Manufacturer	Manufacturer Part
ISL78600EVAL2Z Rev C Evaluation Board BOM				
1		PWB-PCB, ISL78600EVAL2Z, REVC, ROHS	Shenzhen Multilayer PCB Technology Co., Ltd	ISL78600EVAL2ZREVCPCB
1	C43	CAP, SMD, 0603, 2.2µF, 10V, 10%, X7R, ROHS	Murata	GRM188R71A225KE15D
8	C15, C16, C38, C44, C45, C46, C52, C53	CAP, SMD, 0603, 100pF, 100V, 5%, NP0, ROHS	Panasonic	ECJ-1VC2A101J
18	C29, C35-C37, C40a, C42a, C101-C112	CAP, SMD, 0603, 0.01µF, 16V, 10%, X7R, ROHS	Venkel	C0603X7R160-103KNE
13	C17-C28, C51	CAP, SMD, 0603, 0.1µF, 100V, 10%, X7R, ROHS	Venkel	C0603X7R101-104KNE
3	C40, C41, C42	CAP, SMD, 0603, 1.0µF, 10V, 10%, X7R, ROHS	AVX	0603ZC105KAT2A
14	C2, C3, C4, C6-C14, C5L, C5U	CAP, SMD, 0603, 0.022µF, 100V, 10%, X7R, ROHS	Venkel	C0603X7R101-223KNE
1	C39	CAP, SMD, 1206, 1µF, 100V, 10%, X7R, ROHS	Venkel	C1206X7R101-105KNE
1	C1	CAP, SMD, 1812, 1.0µF, 100V, 10%, X7R, ROHS	Venkel	C1812X7R101-105KNE
2	C5, C30	CAP, SMD, 0805, 100pF, 250V, 5%, NP0, ROHS	Murata Electronics	GRM21A5C2E101JW01D
4	C54, C56, C57, C58	CAP, SMD, 0805, 220pF, 1000V, 5%, C0G, ROHS	Vishay/Vitramon	VJ0805A221JXGAT5Z
5	AGND1-AGND5	CONN-MULTI-PURPOSE TEST PT, BLK, ROHS	Keystone	5011
1	J7	CONN-HEADER, 2x4, BRKAWY- 2x36, 2.54mm, ROHS	BERG/FCI	67996-272HLF
2	LEDEN, TOP	CONN-HEADER, 1x2, BRKAWY 1x36, 2.54mm, ROHS	BERG/FCI	68000-236HLF
1	J1	CONN-HEADER, 1x3, BREAKAWY 1x36, 2.54mm, ROHS	BERG/FCI	68000-236HLF
2	JP1, JP2	CONN-HEADER, SHROUDED, TH, 2POS, 2.54mm, R/A, ROHS	Molex	70555-0036
1	ExVDD-VREF-V2P5-VCC-V3P3	CONN-HEADER, 1x5, BRKAWY 1x64, 2.54mm, 0.195x0.118, ROHS	Mill-max	800-10-064-10-001000
1	J2	CONN-HDR, 1x14, BRKAWY 1x64, 2.54mm, 0.195x0.118.ROHS	Mill-max	800-10-064-10-001000
1	J5	CONN-HDR, 1x15, BRKAWY 1x64, 2.54mm, 0.195x0.118.ROHS	Mill-max	800-10-064-10-001000
1	JP6	CONN-HEADER, 2x8, BRKAWY 2x36, R/A, 2.54mm, GOLD, ROHS	Sullins	PEC36DBAN
1	J3	CONN-HEADER, 1x17, BRKAWY 1x36, R/A, 2.54mm, GOLD, ROHS	Sullins	PEC36SBAN
1	JP5	CONN-SOCKET, TH, 16P, 2x8, R/A, INSULATED, 2.54mm, ROHS	Sullins	PPTC082LJBN-RC
3	LEDEN, EN (Enable), TOP	CONN-JUMPER, SHORTING, 2PIN, BLACK, GOLD, ROHS	Sullins	SPC02SYAN
4	D17, D18, D19, D20	DIODE-ZENER, 51V, 6%, 225mW, SMD, 3P, SOT23, ROHS	On Semiconductor	BZX84C51LT1G
1	D16	TVS-AEC-Q101, ZENER DIODE, SMD, SOD-123W, 54V, 4.6A, ROHS	NXP Semiconductor	PTVS54VS1UTR, 115
2	D1, D3	LED-SMART, SMD, 0603, GREEN, 1.7V, 2mA, 570nm, 3.9mcd, ROHS	Osram	LGL29K-G2J1-24-Z
1	D2	LED-SMART, SMD, 0603, 2P, RED, 1.8V, 2mA, 630nm, 4.5mcd, ROHS	OSRAM	LSL29K-G1J2-1-0-2-R18-Z
12	D4-D15	LED-SMART, SMD, 0603, YELLOW, 1.8V, 2mA, 587nm, 7.9mcd, ROHS	OSRAM	LY L29K-J1K2-26-Z

Qty	Reference Designator	Description	Manufacturer	Manufacturer Part
1	U1	IC-LI-ON BATTERY MANAGER, 64P, TQFP, ROHS	Renesas	ISL78600ANZ
4	R27-R30	THERMISTOR-NTC, SMD, 0402, 10K, 1/10W, 5%, ROHS	Murata	NCP15XH103J03RC
1	Q1	TRANSISTOR, NPN, 4P, SOT-223, 80V, 1A, 1W, ROHS	Diodes, Inc.	DCP56-16-13
9	Q3-Q11	TRANSISTOR-MOS, N-CHANNEL, SMD, SOT23, 60V, 1.6A, ROHS	Diodes Inc.	DMN6140L-7
3	Q12, Q13, Q14	TRANSISTOR-MOS, P-CHANNEL, SMD, SSOT3, -60V, -1.2A, ROHS	Fairchild	FDN5618P
12	R4A-R15A	RES, SMD, 0402, 0Ω, 1/16W, 5%, TF, ROHS	Venkel	CR0402-16W-00T
15	R7, R17, R18, R64-R75	RES, SMD, 0402, 1k, 1/16W, 1%, TF, ROHS	Venkel	CR0402-16W-1001FT
4	R23-R26	RES, SMD, 0402, 10k, 1/16W, 1%, TF, ROHS	Panasonic	ERJ-2RKF1002X
4	R20, R21, R22, R32	RES, SMD, 0402, 100k, 1/16W, 1%, TF, ROHS	Panasonic	ERJ2RKF1003
0	R33, R34	RES, SMD, 0402, DNP, DNP, DNP, TF, ROHS		
1	R2	RES, SMD, 0603, 33Ω, 1/10W, 1%, TF, ROHS	Venkel	CR0603-10W-33R0FT
6	R3, R16A, R88, R89, R90, R91	RES, SMD, 0603, 100Ω, 1/10W, 1%, TF, ROHS	Venkel	CR0603-10W-1000FT
2	R19, R94	RES, SMD, 0603, 1k, 1/10W, 1%, TF, ROHS	Panasonic	ERJ-3EKF1001V
12	R36-R47	RES, SMD, 0603, 10k, 1/10W, 1%, TF, ROHS	Venkel	CR0603-10W-1002FT
1	R49	RES, SMD, 0603, 100k, 1/10W, 1%, TF, ROHS	Venkel	CR0603-10W-1003FT
2	R7L, R7U	RES, SMD, 0603, 1.82k, 1/10W, 1%, TF, ROHS	Panasonic	ERJ-3EKF1821V
12	R76-R87	RES, SMD, 0603, 330k, 1/10W, 1%, TF, ROHS	Yageo	RC0603FR-07330KL
4	R96, R97, R98, R99	RES, SMD, 0603, 470Ω, 1/10W, 1%, TF, ROHS	Rohm	MCR03EZPFX4700
6	R35, R48, R50, R51, R92, R93	RES, SMD, 0603, 49.9Ω, 1/10W, 1%, TF, ROHS	Venkel	CR0603-10W-49R9FT
12	R4, R5, R6, R8-R16	RES, SMD, 0603, 910Ω, 1/10W, 1%, TF, ROHS	Yageo	RC0603FR-07910RL
0	R4B-R15B	RES, SMD, 0603, DNP-PLACE HOLDER, ROHS		
1	R1	RES, SMD, 0805, 27Ω, 1/8W, 1%, TF, ROHS	Panasonic	ERJ-6ENF27R0V
1	R31	RES, SMD, 1206, 100Ω, 1/4W, 1%, TF, ROHS	Stackpole	RMC1/8 100R 1% T/R
12	R52-R63	RES, SMD, 1210, 100Ω, 1/2W, 1%, TF, ROHS	Panasonic	ERJ-14NF1000U
0	CR0-CR1-CSEL1-CSEL2, DHI1-DLO1,	DO NOT POPULATE OR PURCHASE		
0	DHI2-DLO2, UPHI, UPLO, DWNHI,	DO NOT POPULATE OR PURCHASE		
0	DWNLO (800-10-064-10-001000)	DO NOT POPULATE OR PURCHASE		
ISL78MICROEVZ REVD Microcontroller Board Bom				
1		PWB-PCB, MCB_MICRO_EVZ, REVD, ROHS	Imagineering Inc	MCB_MICRO_EVZREVDPCB
3	C2, C3, C6	CAP, SMD, 0603, 0.1μF, 16V, 10%, X7R, ROHS	Murata	GRM39X7R104K016AD
1	C4	CAP, SMD, 0603, 1.0μF, 10V, 10%, X7R, ROHS	AVX	0603ZC105KAT2A

Qty	Reference Designator	Description	Manufacturer	Manufacturer Part
2	C1, C5	CAP, SMD, 0603, 4.7µF, 10V, 10%, X5R, ROHS	Venkel	C0603X5R100-475KNE
1	J5	CONN-USB TYPE B, RECEPTACLE, PCB MNT, R/A, ROHS	Assmann Electronics Inc	AU-Y1007-R
1	JP1	CONN-RECEPTACLE, TH, 2x8, 2.54mm, R/A, TIN, ROHS	Sullins	PPPC082LJBN-RC
1	U2	IC-USB uCONTROLLER, 78600-V7.2 PROGRAM, 32P, LQFP, ROHS	Silicon Laboratories	C8051F381-GQ
1	U4	IC-TVS, ESD PROTECTOR, SMD, 6P, SOT-23-6L, 3pF, 6V, ROHS	Stmicroelectronics	USBLC6-2SC6
4	R1, R9, R10, R11	RES, SMD, 0402, 499Ω, 1/16W, 1%, TF, ROHS	Venkel	CR0402-16W-4990FT
2	R12, R13	RES, SMD, 0603, 4.7k, 1/10W, 1%, TF, ROHS	Yageo	9C06031A4701FKHFT
2	R2, R3	RES, SMD, 0402, 1.5k, 1/10W, 1%, TF, ROHS	Panasonic	ERJ-2RKF1501X
6	R4-R8	RES, SMD, 0402, 49.9, 1/10W, 1%, TF, ROHS	Yageo	RC0402FR-0749R9L
1	D1	LED-SMART, SMD, 0603, GREEN, 1.7V, 2mA, 570nm, 3.9mcd, ROHS	Osram	LGL29K-G2J1-24-Z
1	D2	LED-SMART, SMD, 0603, 2P, RED, 1.8V, 2mA, 630nm, 4.5mcd, ROHS	Osram	LSL29K-G1J2-1-0-2-R18-Z
0	Do Not Populate (J9)	CONN-HEADER, 2x4, BRKAWY-2x36, 2.54mm, ROHS	BERG/FCI	67996-272HLF
0	Do Not Populate (5V, 3.3V, GND, DRDY1, DRDY0, CS0, CS1, MISO, MOSI, SCK, P04, P05, P11, P12, P15-P17)	CONN-HEADER, 1x1, BRKAWY 1x64, 2.54mm, 0.195x0.118, ROHS	Mill-max	800-10-064-10-001000
MCB_PS3_Z Power Supply Board BOM				
1		PWB-PCB, MCB_PS3_Z, REVA, ROHS		MCB_PS3_ZREVAPCB
42	R1-R14, R1a-R14a, R1b-R14b	RES, SMD, 1206, 300Ω, 0.33W, 1%, TF, ROHS	Vishay/dale	CRCW2513300RFKEG
14	C1-C14	CAP, SMD, 1206, 10µF, 16V, X7R, ROHS	Venkel	C1206X5R160-106KNE
1	D1	Diode, Schottky, 80V, 0.5A SOD123	Micro Commercial	MBR0580-TP
1	S1	SWITCH-DIP, SPST, SMD, 9POS, TOP ACTUATE, ROHS	E-switch	KAE09LGGT
1	S2	SWITCH-DIP, SPST, SMD, 8POS, TOP ACTUATE, ROHS	E-switch	KAE08LGGT
3	J11, J12	CONN-COMPACT TEST POINT, SMD, ROHS	Keystone	5016
1	JP1	CONN-HEADER, 2x15, BRKAWY 2x36, 2.54mm, ROHS	BERG/FCI	67996-272HLF
1	JP2	CONN-HEADER, 1x2, BRKAWY 1x36, 2.54mm, ROHS	BERG/FCI	68000-236HLF
2	J2, J3	CONN-HEADER, 1x17, BREAKAWY 1x36, 2.54mm, ROHS	BERG/FCI	68000-236HLF
1	J1	CONN-RECEPTACLE, TH, 1x17, 2.54mm, R/A, TIN, ROHS	Sullins	PPTC131LGBN-RC
2	J4, J7	CONN JACK POWER 2.1mm PCB	CUI, Inc.	PJ-102A
16	JP1-Pos 1-15, JP2	CONN-JUMPER, SHORTING, 2PIN, BLACK, GOLD, ROHS	Sullins	SPC02SYAN
0	DO NOT POPULATE: J5	CONN-GEN, BIND, POST, INSUL-RED, THMBNUT-GND	Johnson Components	111-0702-001
0	DO NOT POPULATE: J8	CONN-GEN, BIND, POST, INSUL-BLK, THMBNUT-GND	Johnson Components	111-0703-001

3.6 PCB Layout

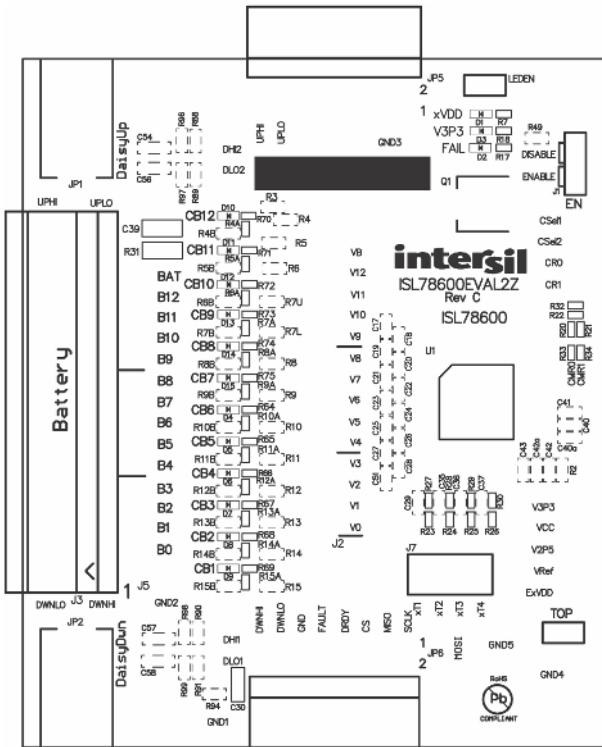

Figure 25. ISL78600EVAL2Z Rev C Top Overlay

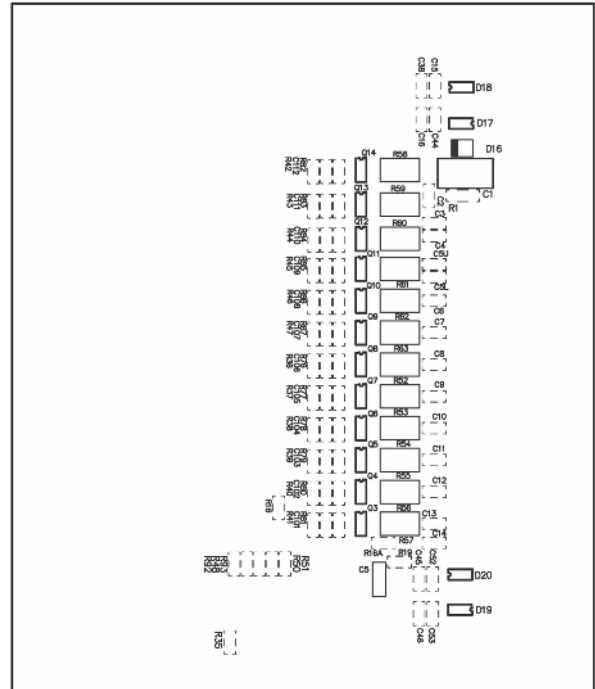

Figure 26. ISL78600EVAL2Z Rev C Bottom Overlay

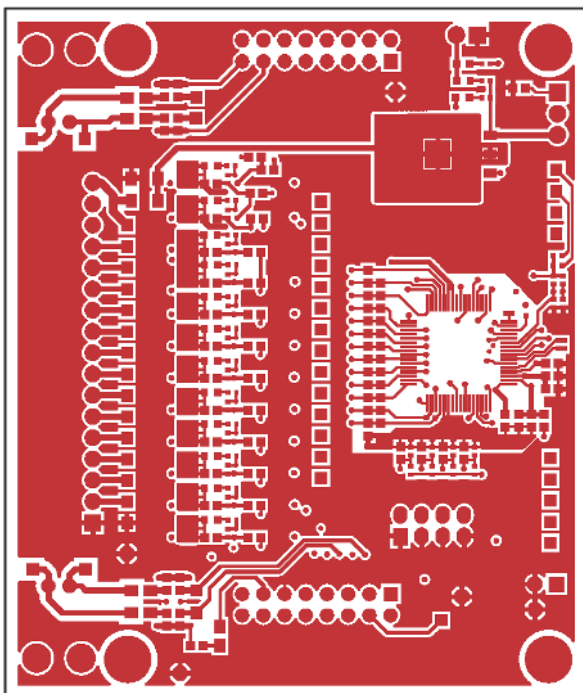

Figure 27. ISL78600EVAL2Z Rev C Top Layer

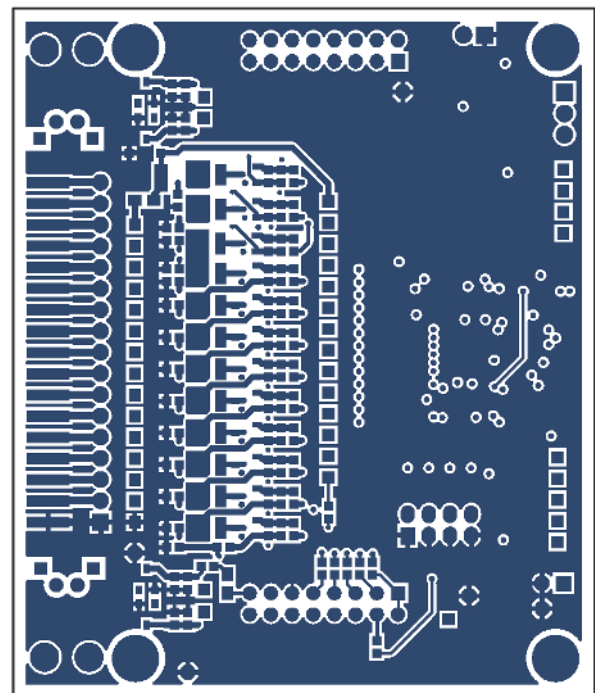

Figure 28. ISL78600EVAL2Z Rev C Bottom Layer

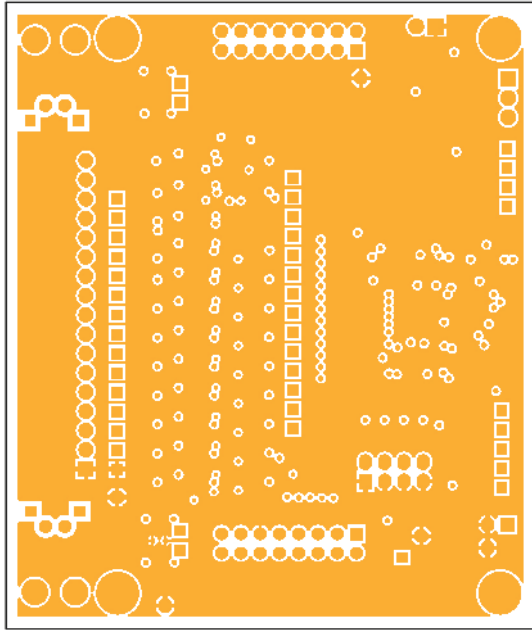

Figure 29. ISL78600EVAL2Z Rev C Mid1 Layer

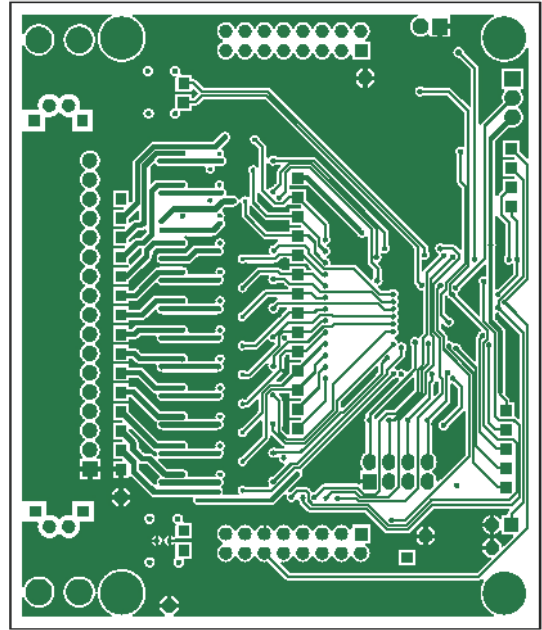

Figure 30. ISL78600EVAL2Z Rev C Mid2 Layer

4. Questions and Answers

The following are common questions we received from customers along with our responses.

Q: When I click start the GUI, nothing happens, I cannot connect to the boards.

A: The most common problem encountered when setting up the boards is a connection error. This is seen after clicking on the Connect button and Device Present “PRES” indicators do not turn Green. The Activity Log at the bottom of the screen also indicates that one or more of the devices cannot be found. If this happens, check that all of the cables are connected properly. The following are other items that you should check:

- For a stand-alone configuration, make sure that there is a shunt on the TOP jumper.
- For a daisy chain configuration, make sure the TOP jumpers are populated, as shown in [Figure 7 on page 9](#). That is, only the top board should have a shunt on the TOP jumper.
- Make sure that the daisy chain cables are connected to the proper device. That is, the DaisyUp connects to DaisyDwn. Make sure that the connections look like those in [Figure 7](#).
- Check that the USB cable is plugged in and that the PC detects the USB connection.
- Check that the V_{BAT} voltages are all within specified limits.
- Check that the ISL78600 enable jumper is in place.
- Inspect the LEDs to identify if all boards are powered properly. If the V3P3 LED is on, but the xVDD LED is off, the device is most likely in a sleep state. If both LEDs are off, the part is not powered or disabled. However, it would be a good idea, if there is a communication problem not solved by the above, to check the voltage on the V3P3 and VREF pins. V3P3 should be 3.3V and the VREF should be 2.5V. If they are not, then there could be a board problem and you should contact your Renesas representative.
- You could try placing the TOP jumper on a lower board (starting from the master) and moving it up, board by board, until communication fails. This requires restarting the GUI, but it indicates if there is a daisy chain hardware component failure or bad cable.

Q: When I enable Polling, the voltages do not update.

A: When the GUI starts, there are no items selected for polling. Click on the “Polling Setup” button and click on the “Quick Setup” button. This enables the most common measurement operations.

Q: When I check an open-wire condition on VC1, VC2, or VC3 by using the switches on the board, the open-wire condition is not detected.

A: When the ISL78600 powers up, the open wire current is set to 100 μ A by default. This current is not high enough to discharge the input capacitors on these three inputs in the time allowed. For the proper open-wire operation on the ISL78600EVAL2Z board, it is necessary to set the ISCN bit to “1”. This bit is found in the “Dev. Setup” register on the “Setup2” tab.

Q: I directly connected two ISL78600EVAL2Z boards together in a daisy chain configuration and I cannot get the daisy chain communication working.

A: Make sure that you are not connecting an ISL78600EVAL2Z RevA board to an ISL78600EVAL2Z RevB or RevC board. The RevA and RevB/RevC boards are not compatible in the direct connect daisy chain configuration. On the RevA board, the circuit for direct connection was the same as for cable connection. As such, it has a series capacitor on both sides of the connection. This is important when a cable isolates the wire if there is a break in the wire or a short to the chassis. However, an on-board connection between two devices does not need both sides to be the same. So, the RevB and RevC boards removed the capacitor and resistor from one side of the connection. The new series capacitor is 100pF, instead of the previous 220pF, and the new series resistor is 1k Ω instead of 470 Ω . To get communication working between a RevA and RevB/RevC board, try using the cable connection.

Note: When contacting Renesas support with questions, click on the About menu item, click on **Read Firmware Version**, and send the GUI and firmware version with your question. See [Figure 31](#).

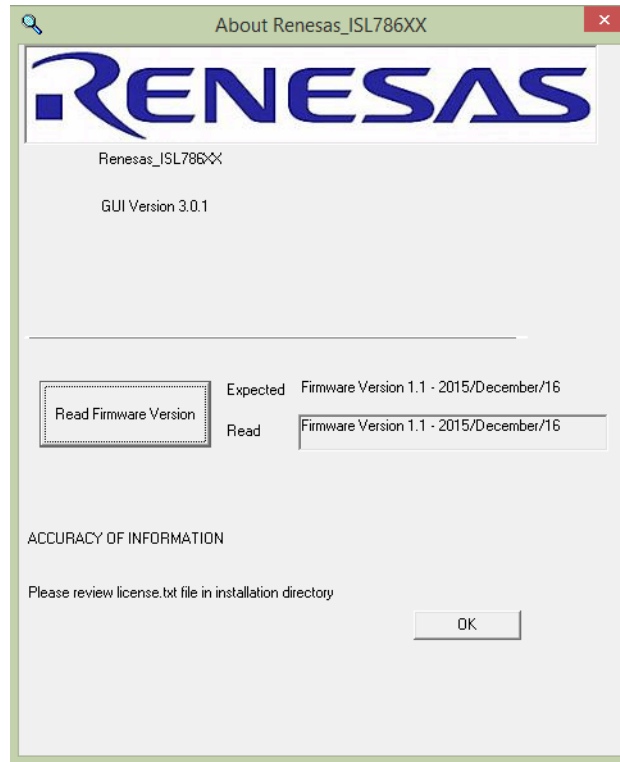

Figure 31. GUI About screen

5. Errata

5.0.1 GUI

When performing an ISL78600 “Read Group” or a Read “Cells in Balance” register, the GUI returns a NACK response. This is normal because the ISL78600 “Cells in Balance” Register was not implemented correctly, so it does not know how to handle the request. Please ignore this fault. [Figure 31 on page 33](#) shows the expected Firmware version of 1.1. However, this release of the evaluation kit only supports firmware version 1.0, which is supplied with the kit.

5.0.2 Evaluation Board

At the time of release, there are no known errors in the design of the evaluation board.

6. Typical Performance Curves

Unless noted: V_{BAT} 24V or 48V as designated, $T_A = +25^\circ\text{C}$. Curves provided below are based on exported data from the ISL78610 GUI software. Measurements are captured from three ISL78600 devices operating in daisy chain mode. Charts are based on either 24V or 48V battery voltage. Measurements are taken with time being the x-axis. This provides information regarding typical subsystem reading variation. Some graphs provide device to device comparisons as well.

6.1 Voltage Readings

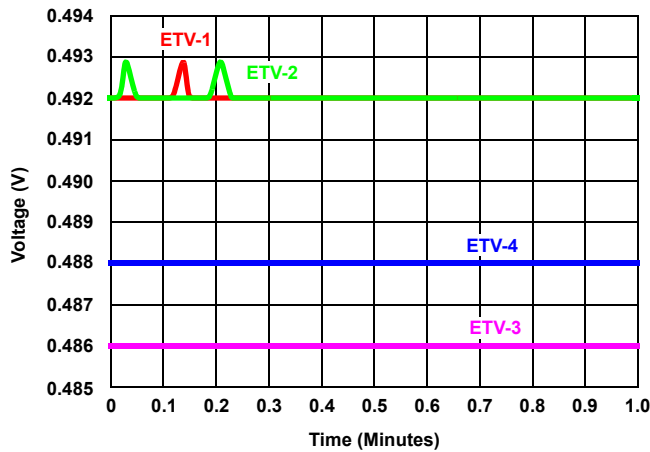

Figure 32. ETV1-4 Device 1 48V

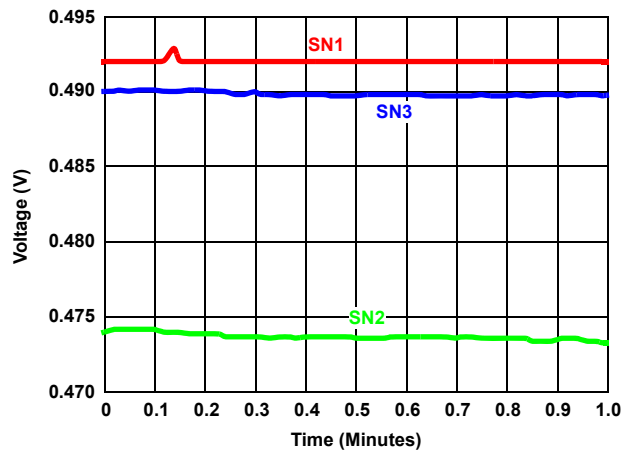

Figure 33. ETV1 Device to Device Spread 48V

6.2 Internal Temperature

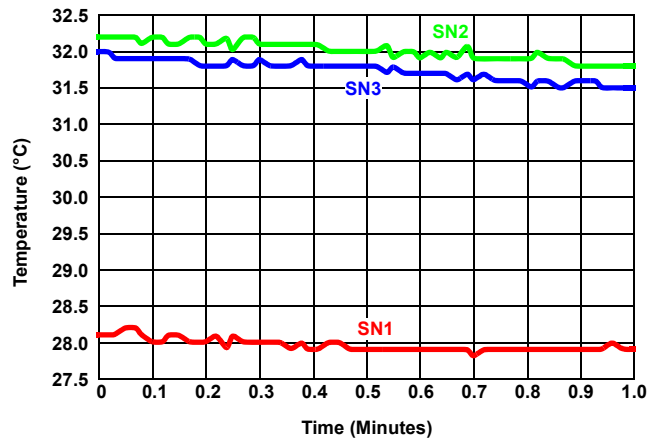

Figure 34. Internal Temperature Device to Device Spread 24V

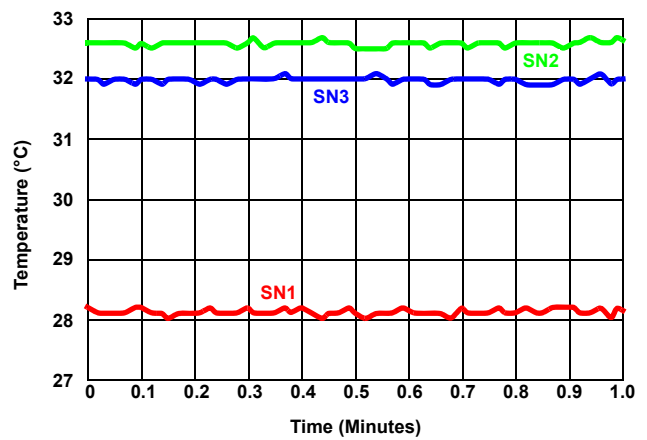

Figure 35. Internal Temperature Device to Device Spread 48V

7. Revision History

Rev.	Date	Description
2.0	Mar.18.19	Applied new format standards and template. Updated links throughout document. Updated ISL7860EVAL2Z information with new Rev C data throughout.
1.0	Oct.19.16	Replaced Figures 2, 3, 10, 11, 12, 14, 15, 16, 18, 19, 20, 21, 22, and 23. Added new figure 4. Text in Step 9 on page 4 to include second LED. Please also change Step 9 on page 5 from, "...notice that there is one green LED (600On)..." to "notice that there are two green LEDs (xVDD and V3P3)..." Text in Step 5 on page 4 includes reference to new Figure 4. New BOM for ISL78600EVAL2Z REVB and ISL78MICROEVZ REVD. Added Q5 in Q&A section on page 27. Changed Errata for EVALUATION BOARD on page 27. Removing old information and adding new. Changes to add RevB to drawings and text. Other minor grammar changes.
0.0	May.24.16	Initial Release

Notice

1. Descriptions of circuits, software and other related information in this document are provided only to illustrate the operation of semiconductor products and application examples. You are fully responsible for the incorporation or any other use of the circuits, software, and information in the design of your product or system. Renesas Electronics disclaims any and all liability for any losses and damages incurred by you or third parties arising from the use of these circuits, software, or information.
2. Renesas Electronics hereby expressly disclaims any warranties against and liability for infringement or any other claims involving patents, copyrights, or other intellectual property rights of third parties, by or arising from the use of Renesas Electronics products or technical information described in this document, including but not limited to, the product data, drawings, charts, programs, algorithms, and application examples.
3. No license, express, implied or otherwise, is granted hereby under any patents, copyrights or other intellectual property rights of Renesas Electronics or others.
4. You shall not alter, modify, copy, or reverse engineer any Renesas Electronics product, whether in whole or in part. Renesas Electronics disclaims any and all liability for any losses or damages incurred by you or third parties arising from such alteration, modification, copying or reverse engineering.
5. Renesas Electronics products are classified according to the following two quality grades: "Standard" and "High Quality". The intended applications for each Renesas Electronics product depends on the product's quality grade, as indicated below.

"Standard": Computers; office equipment; communications equipment; test and measurement equipment; audio and visual equipment; home electronic appliances; machine tools; personal electronic equipment; industrial robots; etc.

"High Quality": Transportation equipment (automobiles, trains, ships, etc.); traffic control (traffic lights); large-scale communication equipment; key financial terminal systems; safety control equipment; etc.

Unless expressly designated as a high reliability product or a product for harsh environments in a Renesas Electronics data sheet or other Renesas Electronics document, Renesas Electronics products are not intended or authorized for use in products or systems that may pose a direct threat to human life or bodily injury (artificial life support devices or systems; surgical implantations; etc.), or may cause serious property damage (space system; undersea repeaters; nuclear power control systems; aircraft control systems; key plant systems; military equipment; etc.). Renesas Electronics disclaims any and all liability for any damages or losses incurred by you or any third parties arising from the use of any Renesas Electronics product that is inconsistent with any Renesas Electronics data sheet, user's manual or other Renesas Electronics document.
6. When using Renesas Electronics products, refer to the latest product information (data sheets, user's manuals, application notes, "General Notes for Handling and Using Semiconductor Devices" in the reliability handbook, etc.), and ensure that usage conditions are within the ranges specified by Renesas Electronics with respect to maximum ratings, operating power supply voltage range, heat dissipation characteristics, installation, etc. Renesas Electronics disclaims any and all liability for any malfunctions, failure or accident arising out of the use of Renesas Electronics products outside of such specified ranges.
7. Although Renesas Electronics endeavors to improve the quality and reliability of Renesas Electronics products, semiconductor products have specific characteristics, such as the occurrence of failure at a certain rate and malfunctions under certain use conditions. Unless designated as a high reliability product or a product for harsh environments in a Renesas Electronics data sheet or other Renesas Electronics document, Renesas Electronics products are not subject to radiation resistance design. You are responsible for implementing safety measures to guard against the possibility of bodily injury, injury or damage caused by fire, and/or danger to the public in the event of a failure or malfunction of Renesas Electronics products, such as safety design for hardware and software, including but not limited to redundancy, fire control and malfunction prevention, appropriate treatment for aging degradation or any other appropriate measures. Because the evaluation of microcomputer software alone is very difficult and impractical, you are responsible for evaluating the safety of the final products or systems manufactured by you.
8. Please contact a Renesas Electronics sales office for details as to environmental matters such as the environmental compatibility of each Renesas Electronics product. You are responsible for carefully and sufficiently investigating applicable laws and regulations that regulate the inclusion or use of controlled substances, including without limitation, the EU RoHS Directive, and using Renesas Electronics products in compliance with all these applicable laws and regulations. Renesas Electronics disclaims any and all liability for damages or losses occurring as a result of your noncompliance with applicable laws and regulations.
9. Renesas Electronics products and technologies shall not be used for or incorporated into any products or systems whose manufacture, use, or sale is prohibited under any applicable domestic or foreign laws or regulations. You shall comply with any applicable export control laws and regulations promulgated and administered by the governments of any countries asserting jurisdiction over the parties or transactions.
10. It is the responsibility of the buyer or distributor of Renesas Electronics products, or any other party who distributes, disposes of, or otherwise sells or transfers the product to a third party, to notify such third party in advance of the contents and conditions set forth in this document.
11. This document shall not be reprinted, reproduced or duplicated in any form, in whole or in part, without prior written consent of Renesas Electronics.
12. Please contact a Renesas Electronics sales office if you have any questions regarding the information contained in this document or Renesas Electronics products.

(Note1) "Renesas Electronics" as used in this document means Renesas Electronics Corporation and also includes its directly or indirectly controlled subsidiaries.

(Note2) "Renesas Electronics product(s)" means any product developed or manufactured by or for Renesas Electronics.

(Rev.4.0-1 November 2017)

Corporate Headquarters

TOYOSU FORESIA, 3-2-24 Toyosu,
Koto-ku, Tokyo 135-0061, Japan
www.renesas.com

Contact Information

For further information on a product, technology, the most up-to-date version of a document, or your nearest sales office, please visit:
www.renesas.com/contact/

Trademarks

Renesas and the Renesas logo are trademarks of Renesas Electronics Corporation. All trademarks and registered trademarks are the property of their respective owners.

ISL78600EVKIT1Z