





CRIMP DATA (TE TERMINAL)					
TERMINAL NAME	SOCKET CONTACT 180 DEG., 50SQMM, WIRE CRIMP				
CRIMP	SIZE	TYPE		RANGE	
WIRE	COROPLAST		50 mm ²		
INSUL					
WIRE STRIP LENGHT	20+/-1	APPLICATOR INSTRUCTION			
TERMINAL APPL SPEC 114-94125	PRODUCT SPECIFICATION		FEED		
TERMINALS APPLIED			SEALS		
2177592-1	-	-	-	-	-
-	-	-	-	-	-
-	-	-	-	-	-
-	-	-	-	-	-
-	-	-	-	-	-
-	-	-	-	-	-
WIRE SIZE (mm ² AWG)	CRIMP HEIGHT		REF SETTING		
50	9,7+/-0,1				
-	-		-		
-	-		-		
-	-		-		
-	-		-		
-	-		-		
-	-		-		
-	-		-		
REMARK: Applicator only used in combination with Coroplast (LV 216-2).					
TYPE: Applicator for loose piece terminals.					
TERMINATOR: HV CRIMPING MACHINE 528008-4					

P	LTR	REVISION RECORD	DATE	DWN	APVD	PRINTED	DWN	26SEP16	CHK	APVD
-	B1	SEE SHEET1	13FEB13	RG	GS	26SEP16	C.WITT	-	-	-
-	C	SEE SHEET1	-	-	-	WEIGHT	DIMENSION (mm)	MATERIAL	HT TR	-
-	D	SEE SHEET1	-	-	-	-	-	-	-	-
-	E	SEE SHEET4	26SEP16	CW	GS	 TOLERANCES UNLESS OTHERWISE SPECIFIED -		 tyco Electronics AMP GmbH D-64625 Bensheim SPARE AND WEAR PARTS LIST		
THIS DRAWING IS A CONTROLLED DOCUMENT FOR TYCO ELECTRONICS CORPORATION. IT IS SUBJECT TO CHANGE AND THE CONTROLLING ENGINEERING ORGANIZATION SHOULD BE CONTACTED FOR THE LATEST REVISION. DIESES ZEICHNUNGSDOKUMENT WIRD DURCH TYCO ELECTRONICS CORPORATION KONTROLLIERT. ÄNDERUNGEN DIE DEM TECHNISCHEN FORTSCHRITT DIENEN, SIND VORBEHALTEN. DEN JEWEILS LETZTGÜLTIGEN ÄNDERUNGSSTAND ERFAHREN SIE AUF ANFRAGE						NAME APPLICATOR HV, 180AK, CAT2, 50SQ.MM				RESTRICTED TO
SCALE		SIZE	DRAWING NO		SHEET	REV				
-		A4	C-541863-2		1 / 4	E				

POS	QTY	TE/PN	DESCRIPTION		S=Spear Parts W=Wear Parts	S	W
1	1	7-0519714-7	BASE PLATE	GRUNDPLATTE		<input checked="" type="checkbox"/>	<input type="checkbox"/>
2	1	0-0519720-1	TOP PLATE	KOPFPLATTE		<input checked="" type="checkbox"/>	<input type="checkbox"/>
3	1	2-0519715-6	HOLDER	HALTER		<input checked="" type="checkbox"/>	<input type="checkbox"/>
4	1	5-0519709-2	CRIMPER LOCATOR	CRIMPERAUFNAHME		<input checked="" type="checkbox"/>	<input type="checkbox"/>
8	1	8-1579009-9	DIE SET HV, 180-AK, 50SQ.MM			<input checked="" type="checkbox"/>	<input checked="" type="checkbox"/>
13	1	7-0519714-8	PLATE	PLATTE		<input checked="" type="checkbox"/>	<input type="checkbox"/>
15	1	2-0519715-7	HOLDER	HALTER		<input checked="" type="checkbox"/>	<input type="checkbox"/>
17	1	2-0519715-8	HOLDER	HALTER		<input checked="" type="checkbox"/>	<input type="checkbox"/>
18	1	8-0519714-0	PLATE	PLATTE		<input checked="" type="checkbox"/>	<input checked="" type="checkbox"/>
19	1	5-0519564-3	HOUSING	GEHÄUSE		<input checked="" type="checkbox"/>	<input type="checkbox"/>
20	1	8-0519714-1	PLATE	PLATTE		<input checked="" type="checkbox"/>	<input type="checkbox"/>
21	1	8-0519714-2	STOP PLATE	ANSCHLAGPLATTE		<input checked="" type="checkbox"/>	<input checked="" type="checkbox"/>
23	1	6-0519514-1	RAM	STÖSSEL		<input checked="" type="checkbox"/>	<input type="checkbox"/>
24	1	2-0519703-8	PIN	STIFT		<input checked="" type="checkbox"/>	<input type="checkbox"/>
25	2	0-2079970-1	GUIDE BUSHING, BALL FÜHRUNGSBUCHSE			<input checked="" type="checkbox"/>	<input type="checkbox"/>
26	2	0-2079969-1	GUIDE PILLAR, SHOULDER FUEHRUNGSSAEULE MIT SCHULT			<input checked="" type="checkbox"/>	<input type="checkbox"/>
31	2	9-0519051-1	ZYL.-STIFT 6M6*30 DIN 6325 -ST			<input checked="" type="checkbox"/>	<input type="checkbox"/>
32	4	3-0519000-2	SCREW, CAP, SOCKET HD, METRIC			<input checked="" type="checkbox"/>	<input type="checkbox"/>
33	1	5-0519585-3	TONGUE	LASCHE		<input checked="" type="checkbox"/>	<input type="checkbox"/>
34	1	0-2079833-1	HANDLE, BOW, OVAL			<input checked="" type="checkbox"/>	<input type="checkbox"/>
35	1	6-0519000-8	SCREW, CAP, SOCKET HD, METRIC			<input checked="" type="checkbox"/>	<input type="checkbox"/>
39	2	3-0519000-7	SCREW, CAP, SOCKET HD, METRIC			<input checked="" type="checkbox"/>	<input type="checkbox"/>
40	1	4-0519000-1	SCREW, CAP, SOCKET HD, METRIC			<input checked="" type="checkbox"/>	<input type="checkbox"/>
41	2	4-0519000-2	SCREW, CAP, SOCKET HD, METRIC			<input checked="" type="checkbox"/>	<input type="checkbox"/>

REMARKS: APPLICATOR HV-180° AK CAT2 NUR ZUR VERARBEITUNG VON 50 MM²										USED ON					
P	LTR	REVISION RECORD			DATE	DWN	APVD	PRINTED	DWN	26SEP16	CHK	APVD			
-	B1	SEE SHEET1			13FEB13	RG	GS	26SEP16	C.WITT	-	-	-			
-	C	SEE SHEET1			-	-	-	WEIGHT	DIMENSION (mm)	MATERIAL	HT TR	-			
-	D	SEE SHEET1			-	-	-	-	-	-	-	-			
-	E	SEE SHEET4			-	-	-	 TOLERANCES UNLESS OTHERWISE SPECIFIED		 tyco Electronics AMP GmbH D-64625 Bensheim SPARE AND WEAR PARTS LIST					
THIS DRAWING IS A CONTROLLED DOCUMENT FOR TYCO ELECTRONICS CORPORATION. IT IS SUBJECT TO CHANGE AND THE CONTROLLING ENGINEERING ORGANIZATION SHOULD BE CONTACTED FOR THE LATEST REVISION. DIESES ZEICHNUNGSDOKUMENT WIRD DURCH TYCO ELECTRONICS CORPORATION KONTROLLIERT. ÄNDERUNGEN DIE DEM TECHNISCHEN FORTSCHRITT DIENEN, SIND VORBEHALTEN. DEN JEWEILS LETZTGÜLTIGEN ÄNDERUNGSSTAND ERFAHREN SIE AUF ANFRAGE								NAME			APPLICATOR HV, 180AK, CAT2, 50SQ.MM			RESTRICTED TO	
SCALE		SIZE		DRAWING NO		SHEET		REV							
-		A4		C-541863-2		2 / 4		E							

THIS DRAWING IS UNPUBLISHED. RELEASED FOR PUBLICATION 2012
 © COPYRIGHT 2012 Tyco Electronics AMP GmbH ALL RIGHTS RESERVED.

LOC		DIST		REVISIONS			
P	LTR	DESCRIPTION	DATE	DWN	APVD		
B		INITIAL REVISION	25APR2012	BM	GS		
B1		ECR-13-002665	14FEB13	RG	GS		
C		ECR-15-012456	21AUG2015	GH	GS		
D		ECR-16-011226	04AUG2016	GH	GS		
E		ECR-16-012972	22SEP2016	CW	GS		

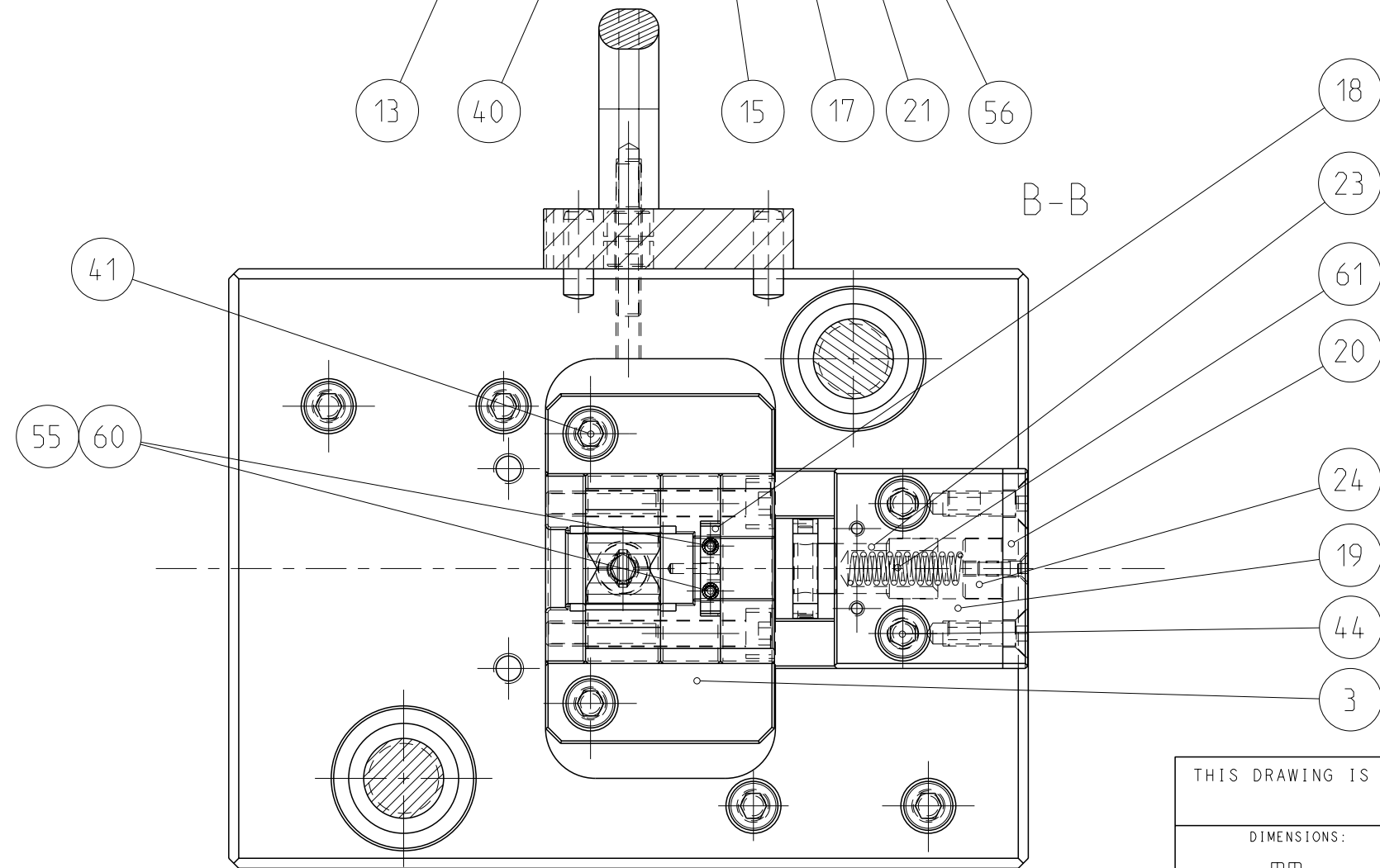
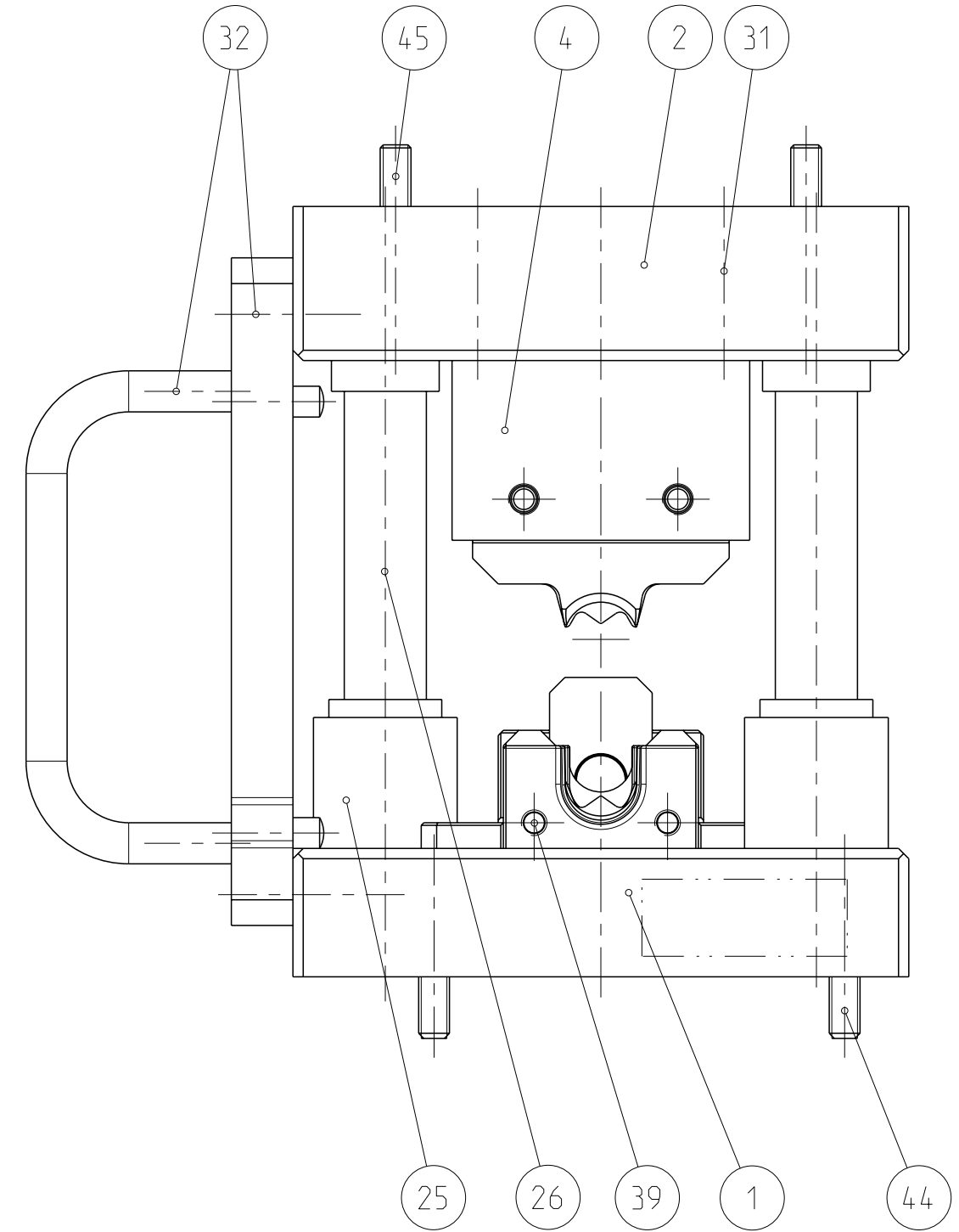
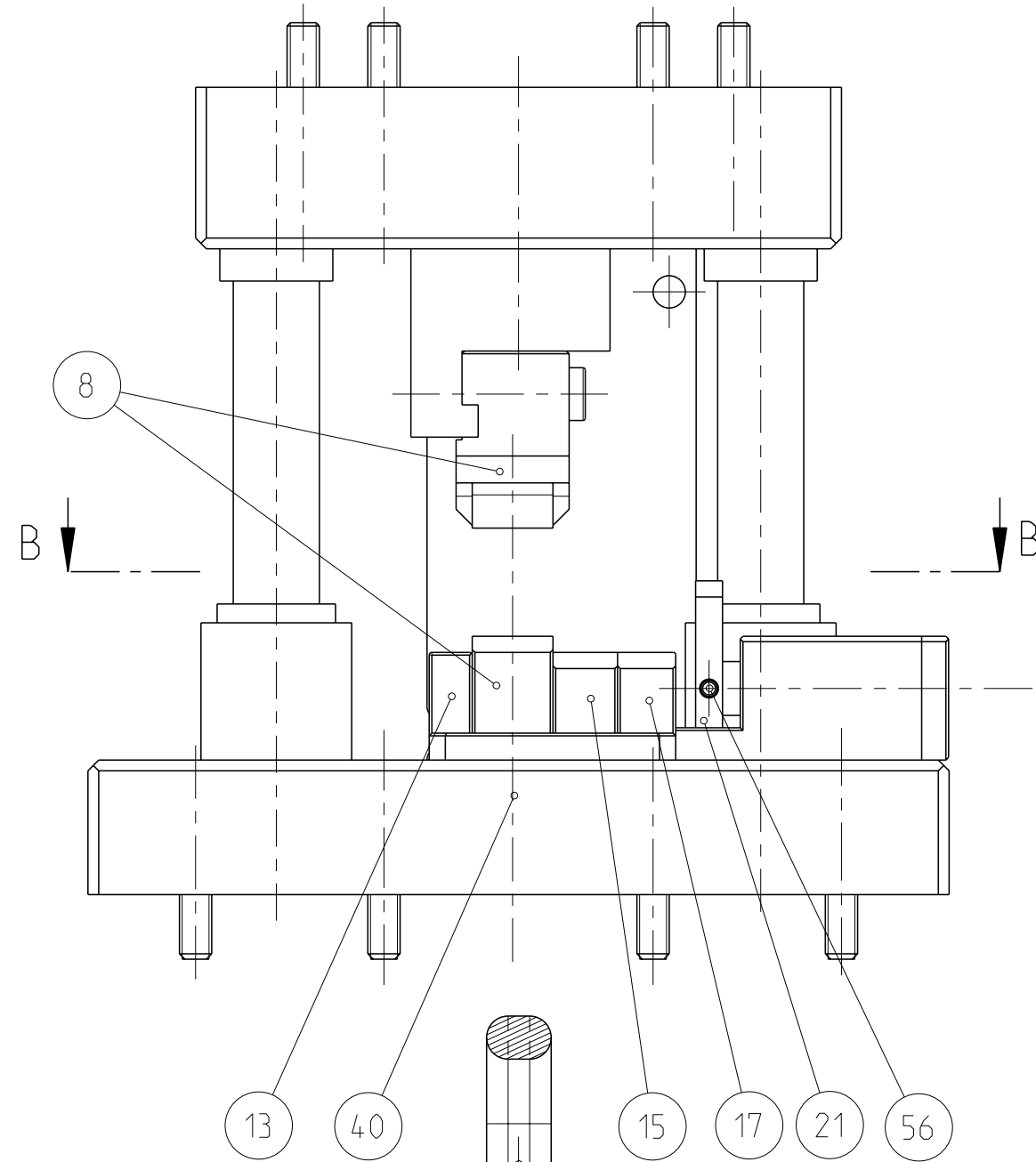
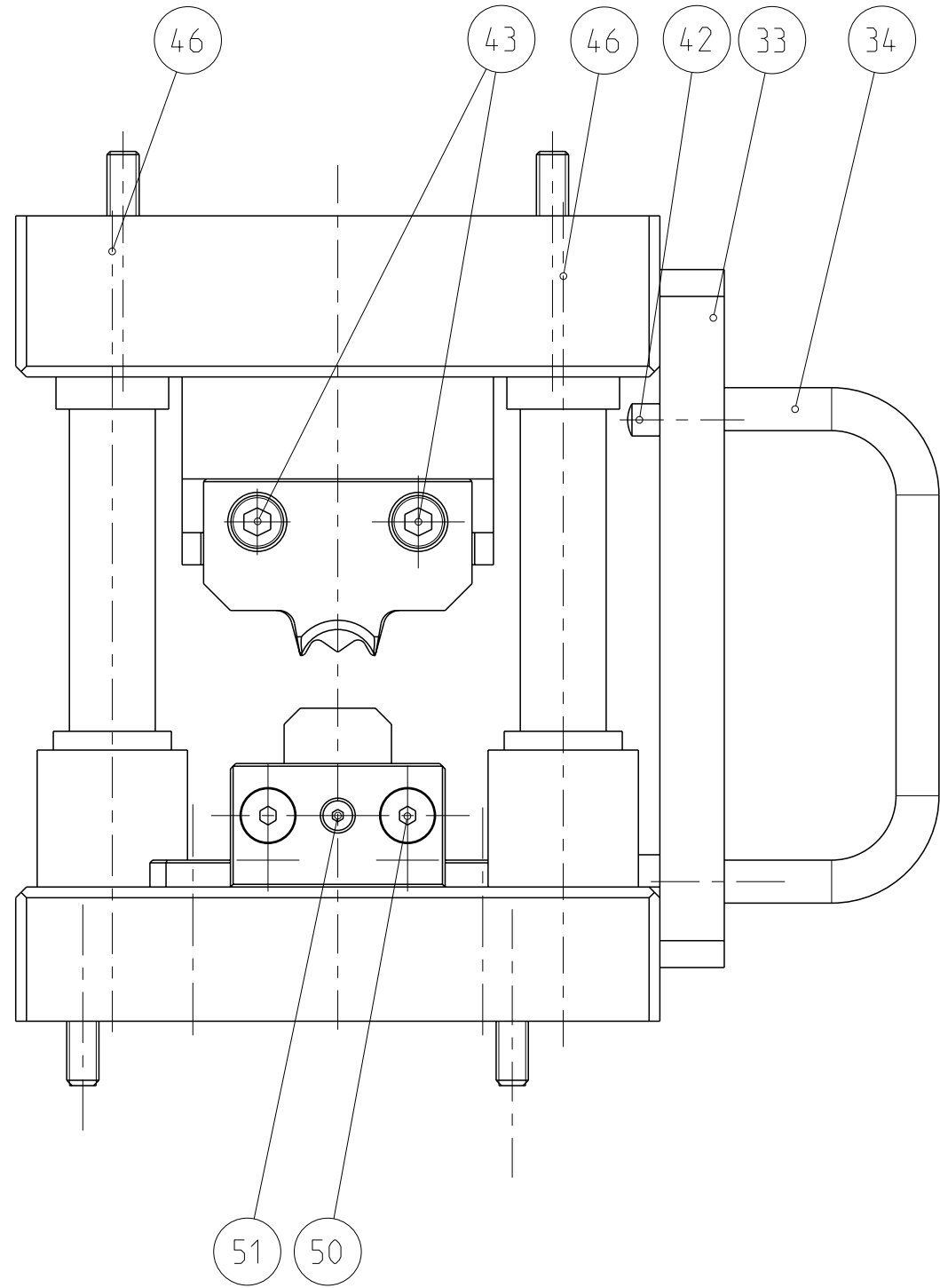

THIS DRAWING IS A CONTROLLED DOCUMENT.		DWN	C. Witt	30MAY2011	 TE Connectivity
DIMENSIONS: mm		CHK	C. Witt	30MAY2011	
TOLERANCES UNLESS OTHERWISE SPECIFIED:		APVD	C. Witt	30MAY2011	
0 PLC ± 1 PLC ± 2 PLC ± 3 PLC ± 4 PLC ± ANGLES ±° FINISH		PRODUCT SPEC	NAME		
MATERIAL		APPLICATION SPEC		APPLICATOR HV, 180AK, CAT2, 50SQ.MM	
		WEIGHT		SIZE CAGE CODE DRAWING NO RESTRICTED TO	
		Customer Drawing		A2 00779 C-541863-2	
		SCALE 1:1		SHEET 4 OF 4 REV E	