

REVISIONS					
REV	ECO	DESCRIPTION	DATE	BY	APPR
A1		RELEASE NEW DRAWING	26DEC17	SULLEN	TOMMY
A2		CHANGE 230 TO 300	09JUL21	MILO	TOMMY

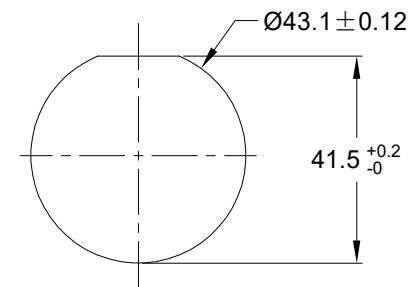
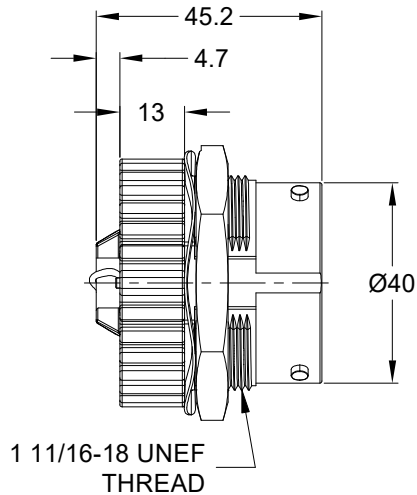
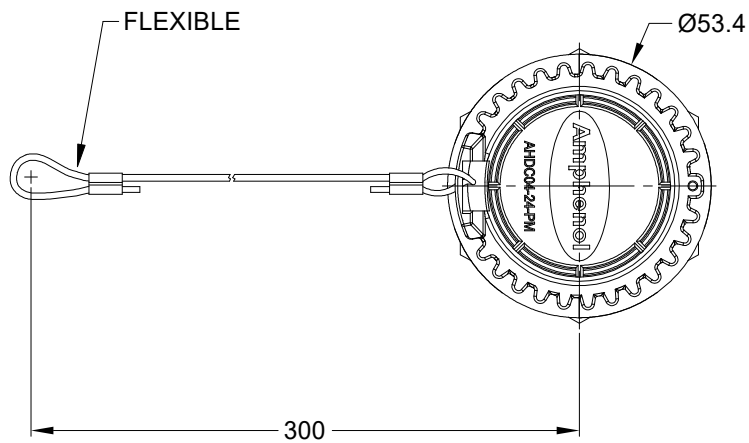

RECOMMENDED PANEL MOUNTING HOLE
RECOMMENDED PANEL THICKNESS: 1.6 TO 4.7MM

NOTES: UNLESS OTHERWISE SPECIFIED

- MATERIAL:
SHELL: THERMOPLASTIC
NUT: THERMOPLASTIC
SEAL: SILICONE RUBBER
CORD: NYLON
LOCK WASHER: STEEL
- COLORS: BLACK
- RoHS COMPLIANT
- COMPATIBLE WITH ALL SIZE 24 AHDP SERIES PLUG.
- ALL DIMENSIONS ARE FOR REFERENCE USE ONLY.

AHDC04-24-PMT					
PART NUMBER		DESCRIPTION		ITEM	
QUANTITY	MATERIALS LIST				
UNLESS OTHERWISE SPECIFIED 1) All dimensions are in metric (mm). 2) Tolerances are as follows: 1 PL DEC ±0.30 2 PL DEC ±0.15 3 PL DEC ±0.08 Fractions ±1/64 Angles ±1° 3) Note reference =		SIGNATURES DRAWN: MILO.DONG CHECKED: SULLEN.ZHANG ENGINEER: APPROVAL: TOMMY.XIE CUSTOMER:		DATE 09JUL21 12JUL21 13JUL21	
MATERIAL SPECIFICATIONS:		THIS DRAWING IS SUPPLIED FOR INFORMATION ONLY. DESIGN FEATURES, SPECIFICATIONS AND PERFORMANCE DATA SHOWN HEREON ARE THE PROPERTY OF THE AMPHENOL CORPORATION. NO RIGHTS OF REPRODUCTION ARE IMPLIED. ALL DIMENSIONS ARE SUBJECT TO NORMAL MANUFACTURING VARIATIONS.		Sine Systems - www.amphenol-sine.com 44724 Morley Drive Clinton Township, MI 48036	
PROCESS SPECIFICATIONS:		SIZE: A C- SCALE: NONE		DWG NO: AHDC04-24-PMT REVISION: A2	
NEXT ASSY:		SHEET 1 OF 1			