

### DESCRIPTION

The MP3304 is a monolithic step-up converter designed for driving arrays of WLEDs from 5V input or a single cell Lithium Ion battery. The MP3304 uses current mode, fixed frequency architecture to regulate the LED current, which is measured through an external current sense resistor. Its low 200mV feedback voltage reduces power loss and improves efficiency.

The MP3304 features up to 50kHz true PWM dimming, which allows the flexible control of the backlighting luminance under wide range of the ambient brightness, and also avoids the possibility of PWM dimming audible noise.

The MP3304 is turned off if an over-voltage condition is present due to an open circuit condition. MP3304 also includes under-voltage lockout, current limiting and thermal overload protection preventing damage in the event of an output overload.

The MP3304 is available in small 8-pin QFN 2x3mm package.

### FEATURES

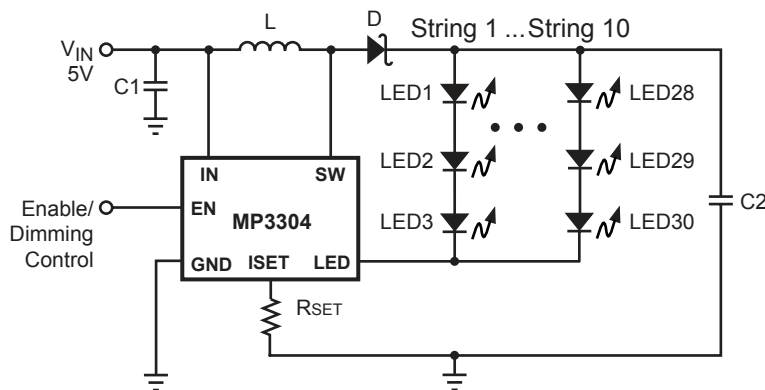
- Internal Power MOSFET
- Drives up to 10 Series White LEDs
- Up to 88% Efficiency
- PWM Dimming Frequency from 250Hz to 50kHz
- 2.2MHz Fixed Switching Frequency
- Open Load Shutdown
- Low 200mV Feedback Voltage
- UVLO, Thermal Shutdown
- Internal 1.3A Current Limit
- Available in 2x3mm QFN8 Package

### APPLICATIONS

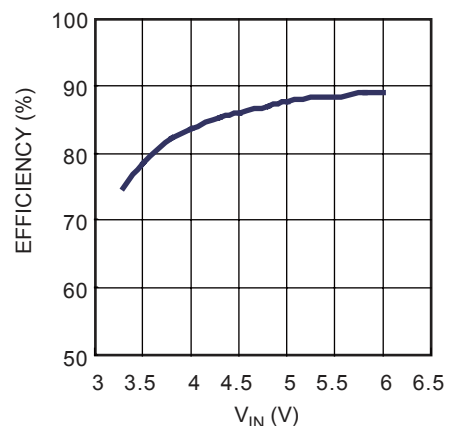
- LCD Panels
- Digital Picture Frames
- Handheld Computers and PDAs
- Digital Still Cameras
- Small LCD Displays

"Monolithic Power Systems", "MPS", and "The Future of Analog IC Technology" are Registered Trademarks of Monolithic Power Systems, Inc.

### TYPICAL APPLICATION



**V<sub>IN</sub> vs. Efficiency**



### ORDERING INFORMATION

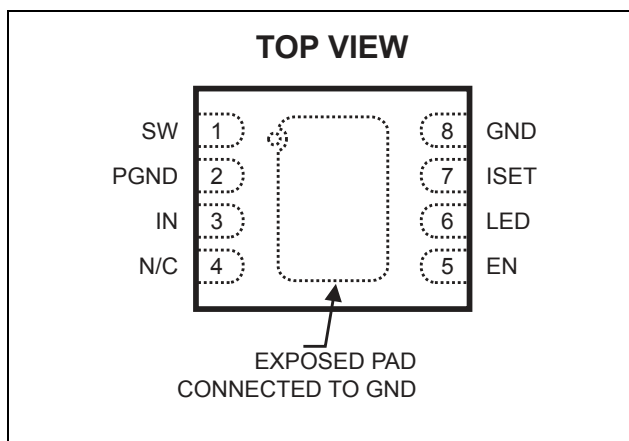
Part Number*	Over Voltage Protection	Package	Top Marking	Free Air Temperature (T <sub>A</sub> )
MP3304ADD**	38V	QFN8(2x 3mm)	5Q	-40°C to +85°C
MP3304BDD**	26V	QFN8(2x 3mm)	6R	-40°C to +85°C
MP3304CDD	20V	QFN8(2x 3mm)	2G	-40°C to +85°C

\*For Tape & Reel, add suffix -Z (eg. MP3304 x DD-Z).

For RoHS compliant packaging, add suffix -LF (eg. MP3304 xDD-LF-Z)

\*\*Contact Factory for Availability

### PACKAGE REFERENCE



#### ABSOLUTE MAXIMUM RATINGS <sup>(1)</sup>

SW Pin, LED Pin.....	-0.5V to +42V
All Other Pins.....	-0.3V to +6.5V
Storage Temperature.....	-55°C to +150°C
Continuous Power Dissipation (T <sub>A</sub> = +25°C) <sup>(2)</sup>	1.9W

#### Recommended Operating Conditions <sup>(3)</sup>

IN Supply Voltage.....	3V to 6V
SW Pin	
MP3304ADD.....	V <sub>IN</sub> to +36V
MP3304BDD.....	V <sub>IN</sub> to +24V
MP3304CDD.....	V <sub>IN</sub> to +18V
Operating Junct. Temp (T <sub>J</sub> ).....	-40°C to +125°C

<b>Thermal Resistance <sup>(4)</sup></b>	<b>θ<sub>JA</sub></b>	<b>θ<sub>JC</sub></b>
QFN8 2x3mm.....	65	13... °C/W

**Notes:**

- 1) Exceeding these ratings may damage the device.
- 2) The maximum allowable power dissipation is a function of the maximum junction temperature T<sub>J (MAX)</sub>, the junction-to-ambient thermal resistance θ<sub>JA</sub>, and the ambient temperature T<sub>A</sub>. The maximum allowable continuous power dissipation at any ambient temperature is calculated by PD<sub>(MAX)</sub> = (T<sub>J (MAX)</sub> - T<sub>A</sub>) / θ<sub>JA</sub>. Exceeding the maximum allowable power dissipation will cause excessive die temperature, and the regulator will go into thermal shutdown. Internal thermal shutdown circuitry protects the device from permanent damage.
- 3) The device is not guaranteed to function outside of its operating conditions.
- 4) Measured on JESD51-7, 4-layer PCB.

## ELECTRICAL CHARACTERISTICS

$V_{IN} = V_{EN} = 5V$ ,  $T_A = +25^{\circ}C$ , unless otherwise noted.

Parameters	Symbol	Condition	Min	Typ	Max	Units
Operating Input Voltage	$V_{IN}$		2.5		6	V
Supply Current (Shutdown)	$I_{IN\_SD}$	$V_{EN} = 0V$		1	2	$\mu A$
Supply Current (Quiescent)	$I_{IN\_QS}$	$V_{ISET}=0.3V$		690	850	$\mu A$
Switching Frequency	$F_{SW}$		1.7	2.2	2.7	MHz
Maximum Duty Cycle	$D_{MAX}$	$V_{ISET} = 0V$	90			%
<b>Under Voltage Lockout</b>						
IN Under Voltage Lockout	$V_{UVLO}$	$V_{IN}$ Rising		2.25	2.45	V
Under Voltage Lockout Hysteresis				92		mV
Open Lamp Shutdown Threshold	$V_{OVP}$	$V_{OV}$ Rising, MP3304ADD		38		V
		$V_{OV}$ Rising, MP3304BDD		26		V
		$V_{OV}$ Rising, MP3304CDD		20		V
<b>Enable</b>						
EN OFF Threshold	$V_{EN\_LOW}$	$V_{EN}$ Falling	0.4			V
EN ON Threshold	$V_{EN\_HIGH}$	$V_{EN}$ Rising			1.8	V
Disable Timer				5		ms
<b>Feedback</b>						
ISET Voltage	$V_{ISET}$	$V_{EN} > 2V$	185	200	215	mV
ISET Input Bias Current		$V_{ISET} = 0.2V$	-600	-300		nA
<b>Output Switch</b>						
SW On-Resistance	$R_{ON}$			0.4		$\Omega$
SW Current Limit		Duty Cycle = 60%		1.33		A
Thermal Shutdown				150		$^{\circ}C$
LED Switch(M2, refer block diagram) On Resistance				0.8		$\Omega$

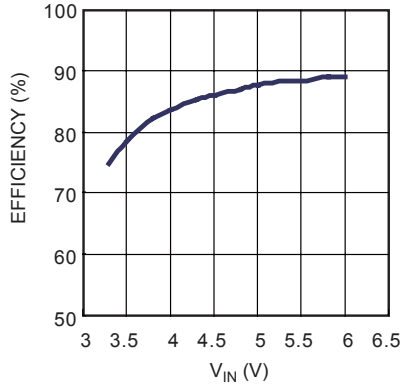
## PIN FUNCTIONS

Pin #	Name	Pin Function
1	SW	Power Switch Output. SW is the drain of the internal MOSFET switch. Connect the power inductor and output rectifier to SW. SW can swing between GND and 36V (MP3304A), 24V (MP3304B) or 18V (MP3304C).
2	PGND	Power Ground.
3	IN	Input Supply Pin. Must be locally bypassed.
4	N/C	No Connect.
5	EN	ON/OFF Control and Dimming Command Input. Holding EN pin low for more than 5ms will turn the part off. To use PWM dimming, add a 250Hz to 50KHz square wave signal to this pin.
6	LED	LED Current Input. This pin is the open-drain output of an internal dimming control switch. Connect the LED cathode to this pin.
7	ISET	LED Current Set. This pin is the source output of an internal dimming control switch. The MP3304 regulates the voltage across the current setting resistor. Tie a current setting resistor from this pin to ground. The regulation voltage is 200mV.
8	GND, Exposed Pad	Ground. Connect Exposed Pad to GND plane for optimal thermal performance.

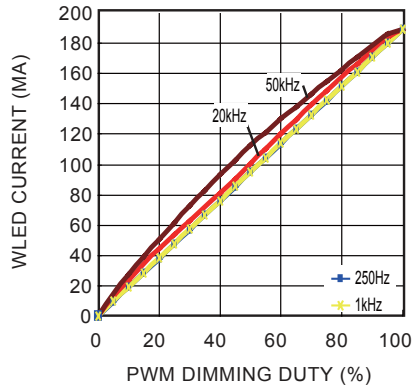
## TYPICAL PERFORMANCE CHARACTERISTICS

$V_{IN} = 5V$ ,  $I_{LED} = 200mA$ , 3WLEDs 10Strings, unless otherwise noted.

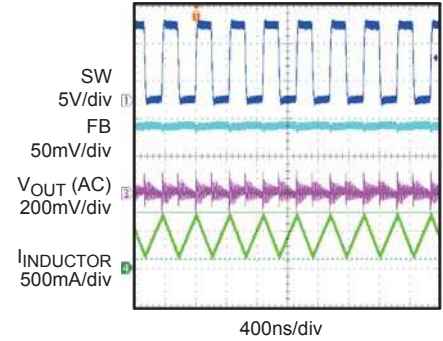
**$V_{IN}$  vs. Efficiency**



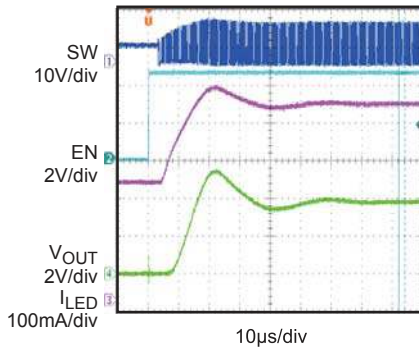
**PWM Dimming Duty vs. WLED Current**



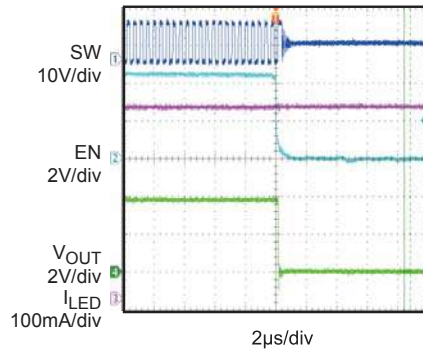
**Steady State Operation**



**Enable Startup**

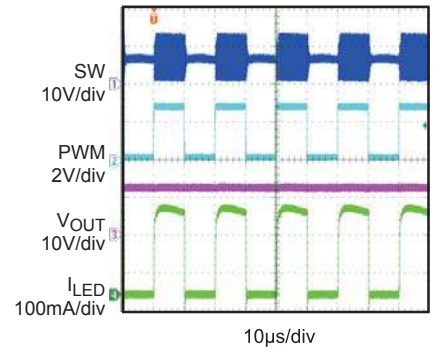


**Enable Shutdown**

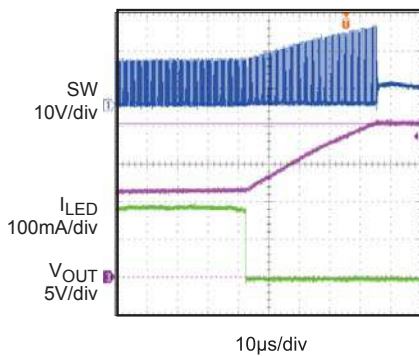


**PWM Dimming**

$f_{PWM} = 50kHz$ , DPWM=50%



**Open Load Protection**



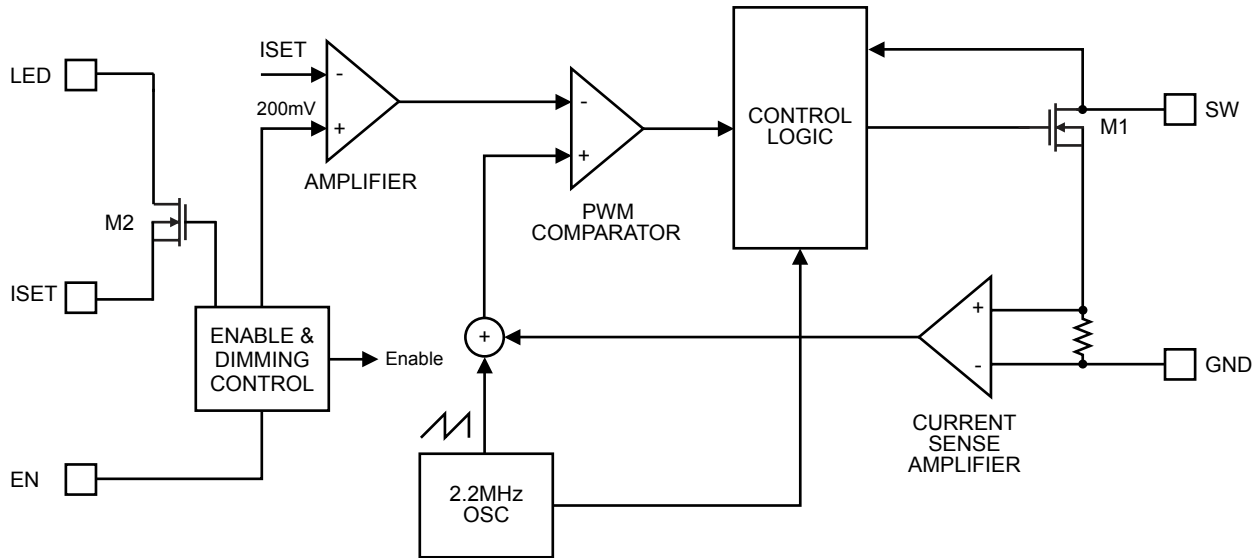
## OPERATION

The MP3304 uses a constant frequency, peak current mode boost regulator architecture to regulate the series string of white LEDs. The operation of the MP3304 can be understood by referring to the block diagram of Figure 1.

At the start of each oscillator cycle the FET is turned on through the control circuitry. To prevent sub-harmonic oscillations at duty cycles greater than 50 percent, a stabilizing ramp is added to the output of the current sense amplifier and the result is fed into the positive input of the PWM comparator. When this voltage equals the output voltage of the error amplifier the power FET is turned off.

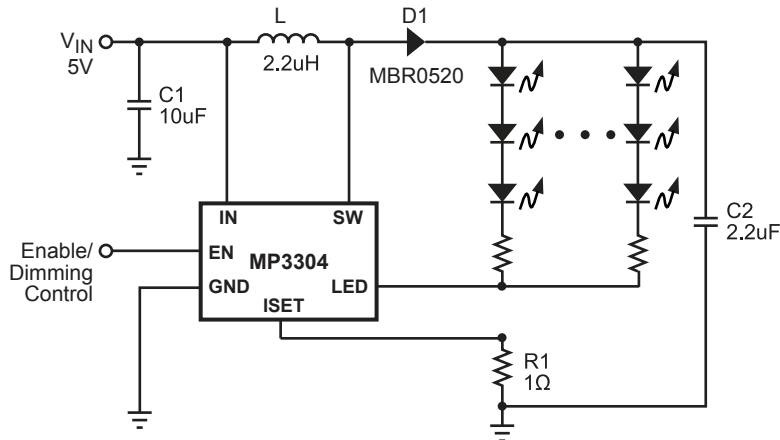
The voltage at the output of the error amplifier is an amplified version of the difference between the 200mV reference voltage and the feedback voltage. In this way the peak current level keeps the output in regulation.

If the feedback voltage starts to drop, the output of the error amplifier increases. This results in more current flowing through the power FET, thus increasing the power delivered to the output.



**Figure 1—Functional Block Diagram**

## APPLICATION INFORMATION



**Figure 2—Circuit for Driving 10 Strings of 3 WLEDs**

A typical application circuit can be seen in Figure 2. The 10 strings of 3 white LEDs can be driven from a 5V voltage at an output current of 200mA. A 2.2µF output capacitor is sufficient for most applications. A 2.2µH inductor with low DCR (Inductor DC resistance) is recommended to improve efficiency. A 10µF ceramic capacitor is recommended for the input capacitance in the real system. Schottky diodes have fast recovery and a low forward voltage are recommended. Schottky diodes rated with 500mA are sufficient for the MP3304. The MP3304 has internal soft-start to limit the amount of current through VIN at startup and to also limit the amount of overshoot on the output.

The ramped voltage that is added to the current sense amplifier reduces the current output as the duty cycle increases. As more LEDs are added, the output voltage rises but the current that can be delivered to the load is reduced as well.

### Setting the LED Current

The LED current is controlled by the current setting resistor, R1. The current through the LEDs is given by:  $I_{LED} = 200mV/R1$ .

Table 1 shows the selection of resistors for a given LED current.

**Table 1— $I_{LED}$  vs. R1 RSET**

$I_{LED}$ (mA)	R1 ( $\Omega$ )
1	200
5	40
10	20
20	10
60	3.33
180	1.11
200	1

### PWM Dimming

Apply a 250Hz to 50kHz square waveform to the EN pin to implement PWM dimming of the LEDs. The minimum recommended amplitude of the PWM signal is 2V.

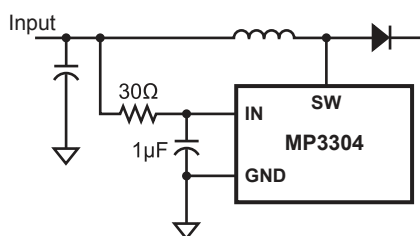
### Open Load Protection

Open Load protection will shut off the MP3304 if the output voltage goes too high. In some cases an LED may fail, this will result in the feedback voltage always being zero. The part will run at maximum duty cycle boosting the output voltage higher and higher. If the output voltage ever exceeds the open load protection threshold voltage, the MP3304 will shut down. The part will not switch again until the power is recycled. For MP3304A, MP3304B, and MP3304C, the open load protection threshold voltages are 38V, 26V, and 20V respectively.

### Layout Considerations

Careful attention must be paid to the PCB board layout and components placement. Proper layout of the high frequency switching path is critical to prevent noise and electromagnetic interference problems. The loop of MP3304 SW to GND pin, output diode, and output capacitor is flowing with high frequency ripple current, it must be as short as possible.

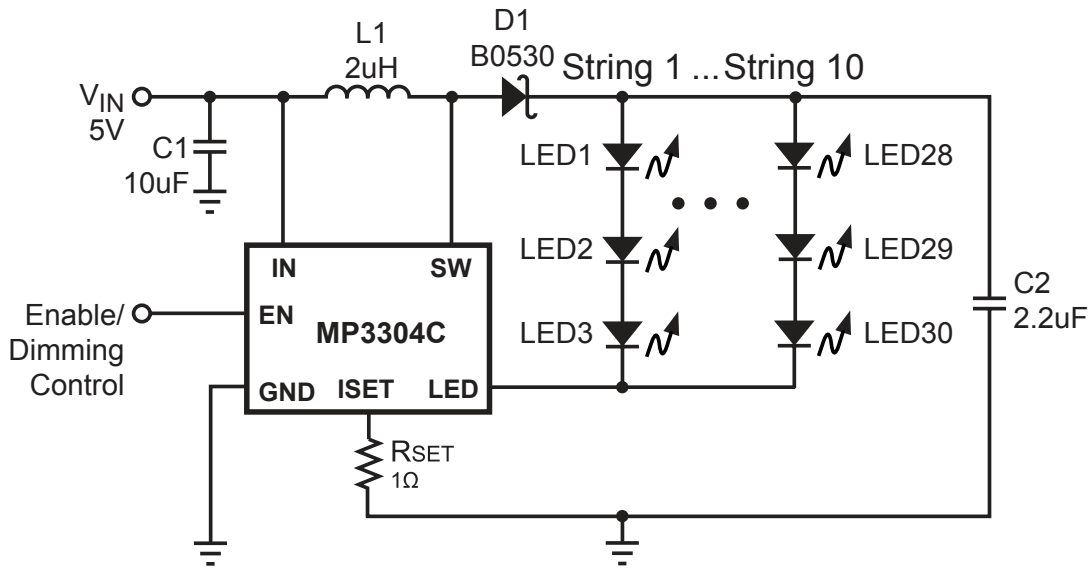
The IN pin of the IC must be locally bypassed. A RC filter is highly recommended for eliminating the noise on IN pin. It could be implemented as shown in Figure 3.



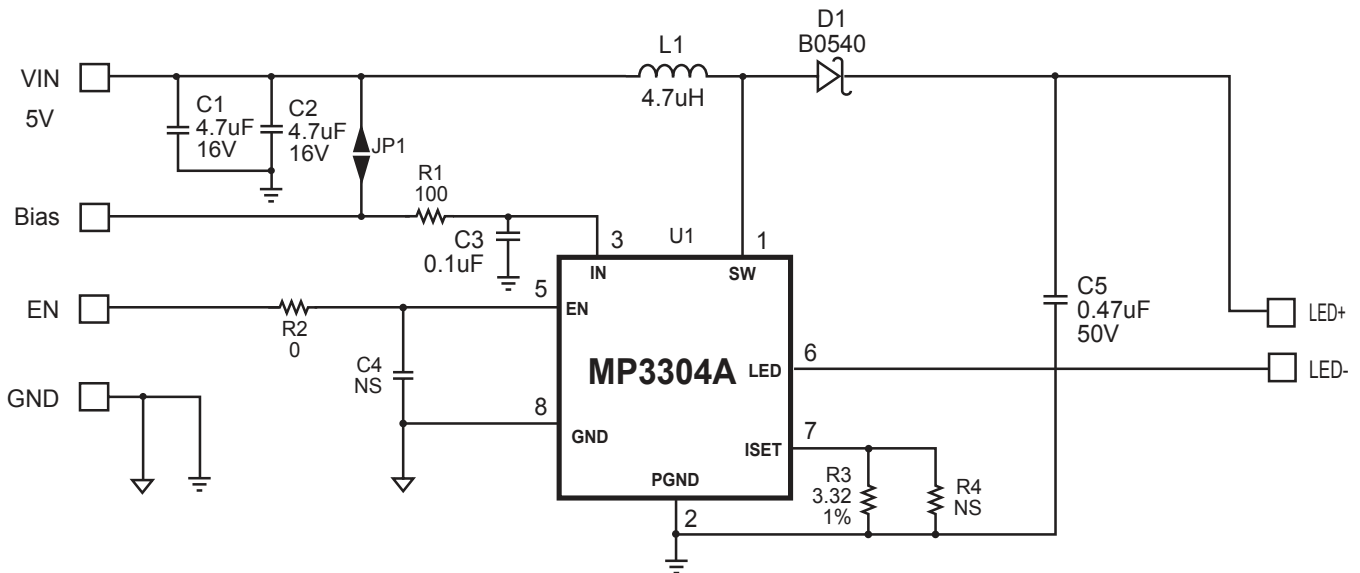
**Figure 3—Input Bias Filtering**



**TYPICAL APPLICATION CIRCUITS**

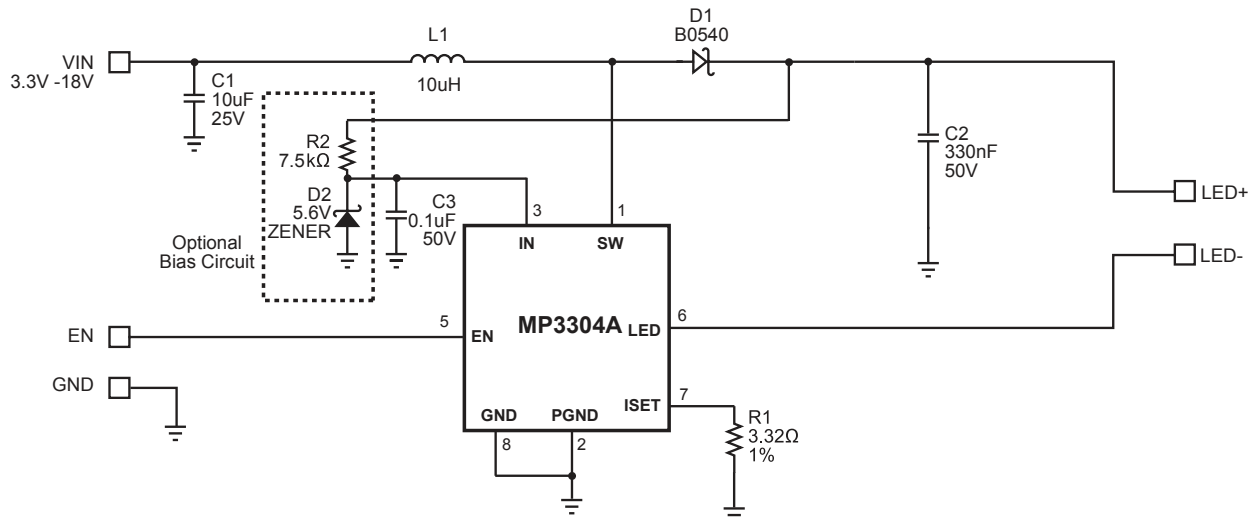


**Figure 4 — Driving 30 WLEDs (3 WLEDs in Series and 10 Strings Paralleled) with 5V Input Voltage**



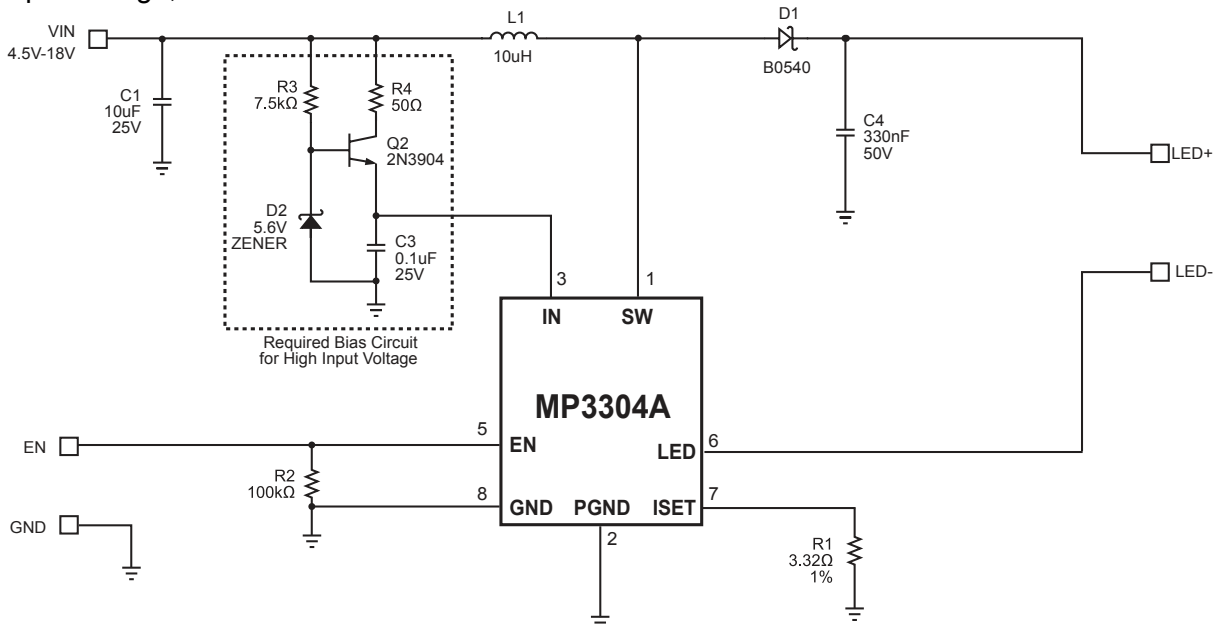
**Figure 5 — Driving 27 WLEDs (9 WLEDs in Series and 3 Strings Paralleled) with 5V Input Voltage**

**TYPICAL APPLICATION CIRCUITS** (continued)



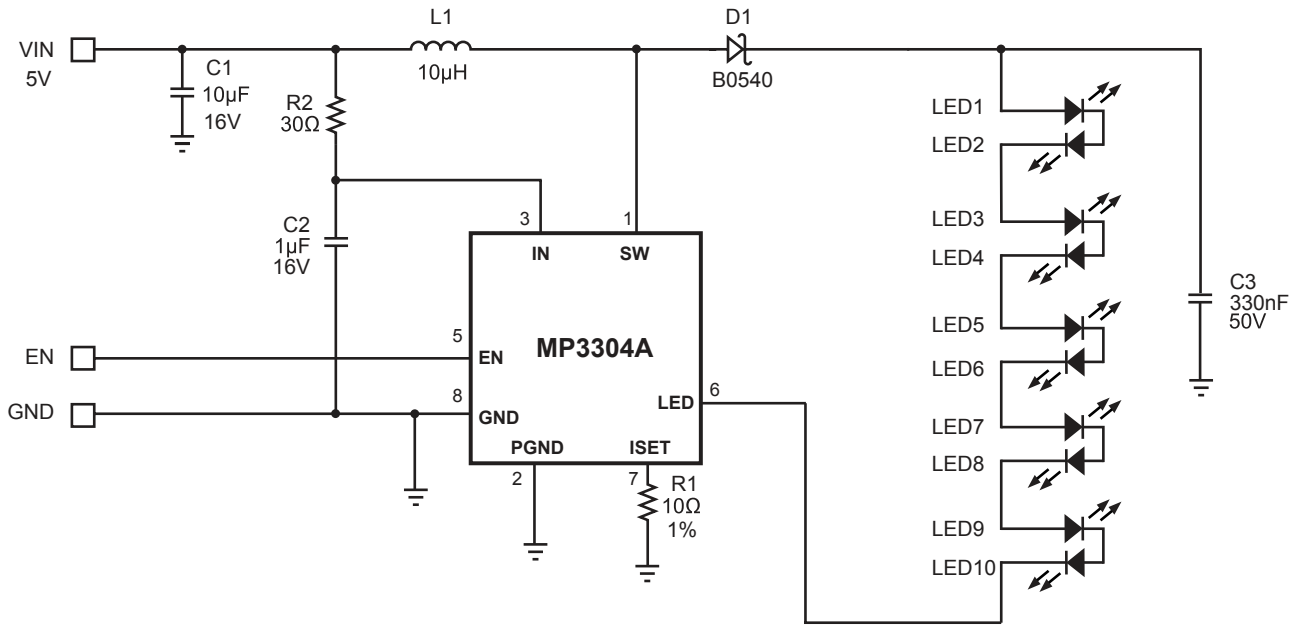
**Figure 6 — Driving 27 WLEDs (9 WLEDs in Series and 3 Strings Paralleled) with 3.3V-18V Input Voltage**

In order to improve the MOSFET on-resistance at low input voltage and make the chip compatible for high input voltage, the additional bias circuit should be used.



**Figure 7 — Wide Input Voltage Step-up Converter for 27 WLEDs  
(9 WLEDs in Series and 3 Strings Paralleled)**

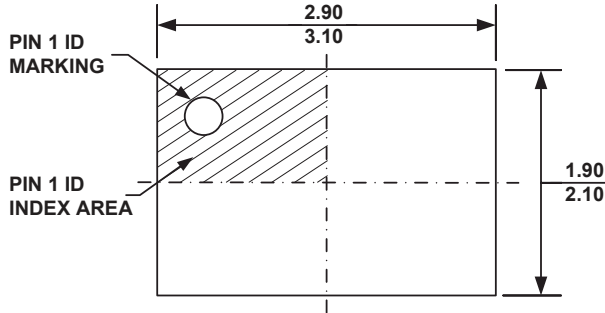
**TYPICAL APPLICATION CIRCUITS** (continued)



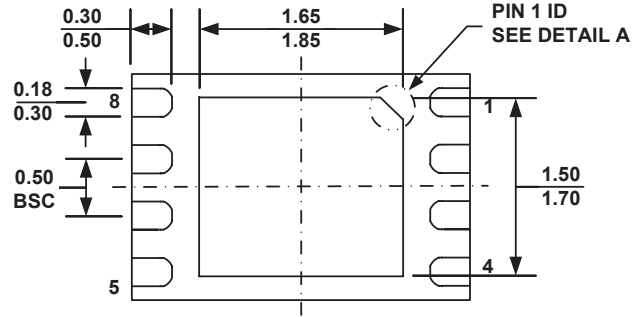
**Figure 8 — Driving 10 WLEDs in Series with 5V Input Voltage**

## PACKAGE INFORMATION

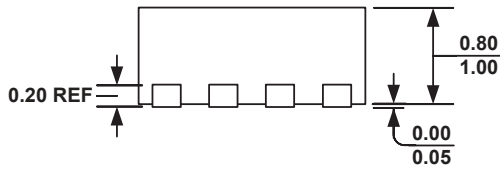
### QFN8 (2mm x 3mm)



**TOP VIEW**

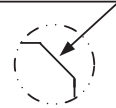


**BOTTOM VIEW**



**SIDE VIEW**

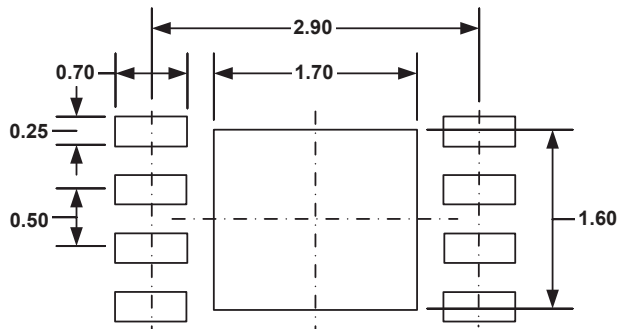
**PIN 1 ID OPTION A**  
0.30x45° TYP.



**PIN 1 ID OPTION B**  
R0.20 TYP.



**DETAIL A**



**RECOMMENDED LAND PATTERN**

#### NOTE:

- 1) ALL DIMENSIONS ARE IN MILLIMETERS.
- 2) EXPOSED PADDLE SIZE DOES NOT INCLUDE MOLD FLASH.
- 3) LEAD COPLANARITY SHALL BE 0.10 MILLIMETER MAX.
- 4) DRAWING CONFORMS TO JEDEC MO-229, VARIATION VCED-2.
- 5) DRAWING IS NOT TO SCALE.

**NOTICE:** The information in this document is subject to change without notice. Users should warrant and guarantee that third party Intellectual Property rights are not infringed upon when integrating MPS products into any application. MPS will not assume any legal responsibility for any said applications.