

## 19 V, 75 W Energy Star-compliant SMPS using the L6563S and the L6566A

Data brief

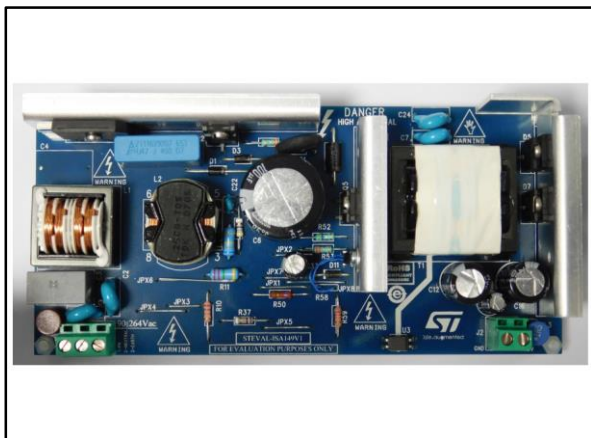

### Description

The STEVAL-ISA149V1 implements a 75 W SMPS reference design, tailored to the specifications of a typical high-end portable computer power supply (adapter). The peculiarities of this design are its very high efficiency at light load, and excellent global efficiency for a two-stage architecture. The high efficiency at high load is achieved without using synchronized rectification at the secondary side, resulting in a very cost-effective solution. The circuit is made up of two stages: a front-end PFC using the L6563S, and a flyback converter based on the L6566A. The CV/CC controller TSM1014 allows accurate current limitation on the secondary side. The flyback stage works as master and is dedicated to controlling circuit operation, including standby and protection functions. Additionally, it switches the PFC stage on and off by means of a dedicated pin ( $V_{CC\_PFC}$ ), helping to achieve excellent efficiency even at light load, with a low level of complexity. Efficiency during active load and light load operation is compliant with Energy Star® eligibility criteria for both external (EPA rev. 2.0 EPS) and computer integrated (EPA rev. 4.0 COMPUTERS) power supplies. In addition, this design is also compliant with the latest computer requirements.

### Features

- Universal input mains range: 90 - 264 Vac, Freq. 45 - 65 Hz
- Output voltage: 19 V @ 4 A continuous operation
- Mains harmonics: in accordance with EN61000-3-2 Class-D or JEIDA-MITI Class-D
- Standby mains consumption: < 0.14 W @ 230 Vac, < 0.085 W @ 115 Vac
- Active load average efficiency: greater than 87% without synchronous rectification
- EMI: in accordance with EN55022-Class-B
- Safety: in accordance with EN60950
- Dimensions: 78 x 170 mm, 25 mm component maximum height
- PCB: single side, 70  $\mu$ m, CEM-1, mixed PTH/SMT
- RoHS compliant

# 1 Schematic diagram

Figure 1: STEVAL-ISA149V1 circuit schematic

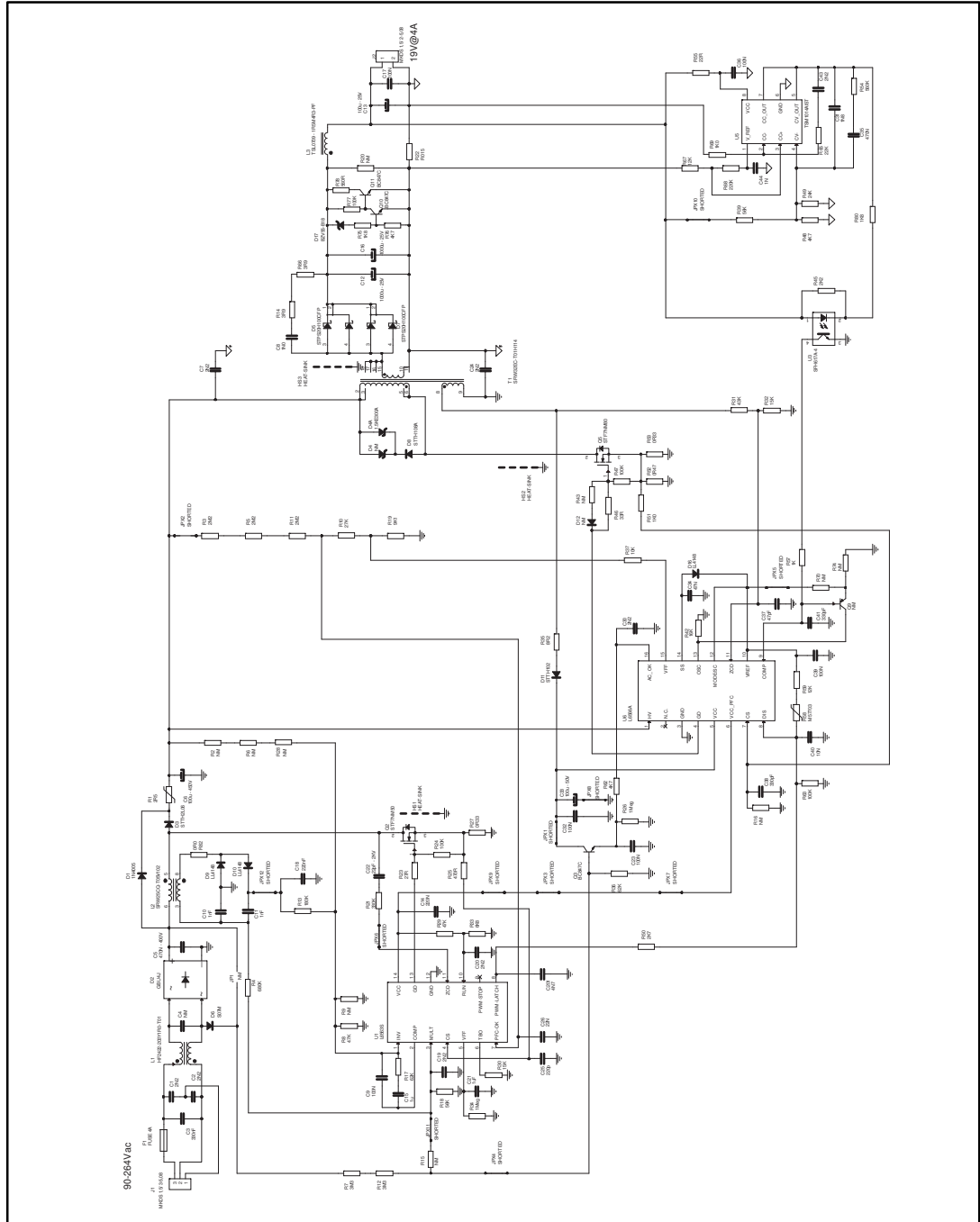

## 2 Revision history

Table 1: Document revision history

Data	Revision	Changes
22-Jul-2014	1	Initial release
17-Jun-2016	2	Updated board photo on the cover page

**IMPORTANT NOTICE – PLEASE READ CAREFULLY**

STMicroelectronics NV and its subsidiaries ("ST") reserve the right to make changes, corrections, enhancements, modifications, and improvements to ST products and/or to this document at any time without notice. Purchasers should obtain the latest relevant information on ST products before placing orders. ST products are sold pursuant to ST's terms and conditions of sale in place at the time of order acknowledgement.

Purchasers are solely responsible for the choice, selection, and use of ST products and ST assumes no liability for application assistance or the design of Purchasers' products.

No license, express or implied, to any intellectual property right is granted by ST herein.

Resale of ST products with provisions different from the information set forth herein shall void any warranty granted by ST for such product.

ST and the ST logo are trademarks of ST. All other product or service names are the property of their respective owners.

Information in this document supersedes and replaces information previously supplied in any prior versions of this document.

© 2016 STMicroelectronics – All rights reserved