

MODEL CUB7T1 PROGRAMMABLE GENERAL PURPOSE ELECTRONIC TIMER



- 9 PROGRAMMABLE TIMER RANGES
- 3 (8 Digit 0.35") LCD DISPLAY OPTIONS (Reflective, Red Transmissive, Yellow/Green Transmissive) with "Timer Active" annunciator
- REPLACEABLE INTERNAL LITHIUM BATTERY (provides up to 6 years of uninterrupted operation)
- BOTH FRONT PANEL PROGRAM AND RESET BUTTONS ARE INDIVIDUALLY ENABLED
- WIRE CONNECTIONS VIA SCREW CLAMP TYPE TERMINALS
- FRONT PANEL AND REMOTE RESET INPUT
- NEMA 4X/IP65 SEALED FRONT BEZEL



DESCRIPTION

The CUB7T1 is an 8-digit miniature programmable timer with large 0.35 inch (8.90 mm) high digits. It has an LCD read-out available in Positive Image Reflective (CUB7T100), Negative Image Transmissive with yellow/green backlighting (CUB7T110) or red backlighting (CUB7T120). The backlight versions require an external 9 to 28 VDC power supply. The display will wrap around from a full display of "99999999" to "00000000" when an overflow occurs. An annunciator, located in the upper left hand corner of the display, blinks at 2 Hz when the signal input is activated. The CUB7T1 operates from a signal voltage of 10 to 300 V (AC 50/60 Hz or DC).

The CUB7T timers use a CMOS LSI chip, mounted on a gold-plated substrate, that is electrically connected by ultrasonic wire-bonding. Proven micro-electronic assembly and manufacturing techniques provide these units with the reliability and dependability required for industrial service.

The CUB7T series is housed in a lightweight, high impact plastic case with a clear viewing window. The sealed front panel with the silicone rubber buttons meets NEMA 4X/IP65 specifications for wash-down and/or dusty environments, when properly installed.

SAFETY SUMMARY

All safety related regulations, local codes and instructions that appear in the bulletin or on equipment must be observed to ensure personal safety and to prevent damage to either the instrument or equipment connected to it. If equipment is used in a manner not specified by the manufacturer, the protection provided by the equipment may be impaired.

SPECIFICATIONS

1. **DISPLAY:** 8-digit LCD, 0.35" (8.90 mm) high digits.
2. **POWER SOURCE:** Replaceable Internal 3.0 V lithium battery to provide up to 6 years of continuous operation. (Battery life is dependent upon usage. Contacts that remain closed for long periods of time reduce battery life.)
3. **BACKLIGHT POWER REQUIREMENTS:** 9 to 28 VDC; 35 mA. typical, 50 mA max. Above 26 VDC, derate max. operating temperature to 40°C.
4. **ANNUNCIATOR:** Annunciator in the upper left corner of the display flashes at a 2 Hz rate when the signal input is activated.
5. **SIGNAL INPUT:** (LS terminal #4)
Voltage Input (CUB7T1xx): 10 V min. to 300 V max. (AC 50/60 Hz. or DC) to Common. 150 V max. for backlight versions. Input current 0.5 mA max. *ANY off-state leakage current may activate the timer.* Constant voltage applied to the input will actuate the timer. Due to the internal digital filtering to this input, up to 30 msec of error may be added per activation of the signal input.
6. **REMOTE RESET:** 15 msec min. pulse width (active low) from 3.0 V bipolar output, an open collector transistor, or a switch contact to common.
7. **ACCURACY:** 0.025% (+ up to 30 msec per activation of signal input—CUB7T1xx only)
8. **ENVIRONMENTAL CONDITIONS:**
Operating Temperature Range: 0 to 50°C Derate max. operating temperature to 40°C above 26 VDC (Backlight versions).
Storage Temperature: -30 to 80°C
Operating and Storage Humidity: 85% max. relative humidity (non-condensing) from 0°C to 50°C.
Vibration According to IEC 68-2-6: Operational 5 to 500 Hz, in X, Y, Z direction for 1.5 hours, 5 g's.
Shock According to IEC 68-2-27: Operational 30 g, 11 msec in 3 directions.
Altitude: Up to 2000 meters
9. **CERTIFICATIONS AND COMPLIANCES:**
SAFETY
 IEC 61010-1, EN 61010-1: Safety requirements for electrical equipment for measurement, control, and laboratory use, Part 1.
 IP65 Enclosure rating (Face only), IEC 529
 Type 4X Enclosure rating (Face only).

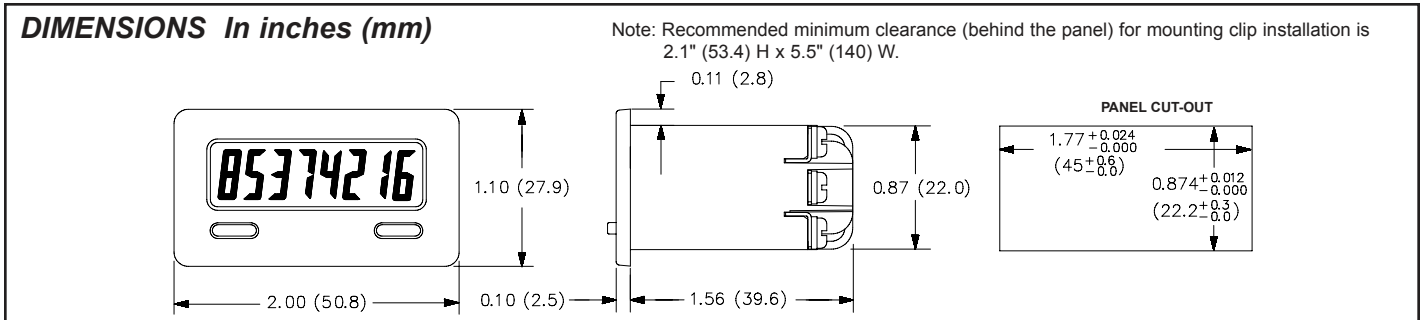
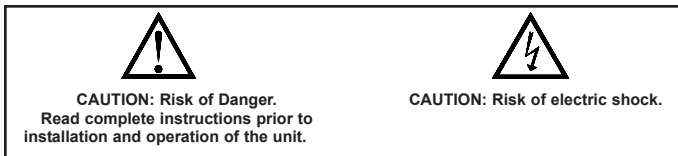

ELECTROMAGNETIC COMPATIBILITY

Immunity to EN 50082-2

Electrostatic discharge	EN 61000-4-2	Level 2; 4 Kv contact Level 3; 8 Kv air
Electromagnetic RF fields	EN 61000-4-3	Level 3; 10 V/m 80 MHz - 1 GHz
Fast transients (burst)	EN 61000-4-4	Level 4; 2 Kv I/O Level 3; 2 Kv power ¹
RF conducted interference	EN 61000-4-6	Level 3; 10 V/rms 150 KHz - 80 MHz
Simulation of cordless telephone	ENV 50204	Level 3; 10 V/m 900 MHz ± 5 MHz 200 Hz, 50% duty cycle

Emissions to EN 50081-1

RF interference	EN 55022	Enclosure class B
-----------------	----------	-------------------

Notes

1. Backlit powered units require a power line filter to be installed, RLC LFIL0000 or equivalent, so as not to impair the function of the backlighting.

Refer to EMC Installation Guidelines for additional information.

9. CONNECTIONS: Wire clamping screw terminals.

Wire Strip Length: 0.3" (7.5 mm)

Wire Gauge: 30-14 AWG copper wire

Torque: 5 inch-lbs (0.565 N-m) max

10. CONSTRUCTION: High impact plastic case with clear viewing window.

The front panel meets NEMA 4X/IP65 requirements for indoor use when properly installed. Installation Category I, Pollution Degree 2. Panel gasket and mounting clip included.

11. WEIGHT: 2 oz. (57 grams) [with battery]

TIMER RANGE SELECTION

The CUB7T's timer range can be modified in the Program mode. The Program mode uses the PGM button (refer to photo) to switch between Program and Operate modes. The RESET button (refer to photo) is used to select the desired timer range.

Note: Timer range and accumulated time on the display will be lost if the battery is removed from the unit

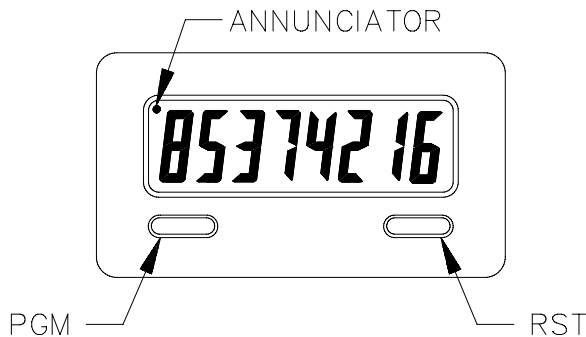

Connect wires between RST EN (Reset Enable) and COM. (Common); and between HS (Program Enable) and COM. (Common) to enable front push buttons. Press the PGM button to enter Program Mode, allowing selection of the desired timer range. The display will show 00000.000 (Timer Range 0.001 sec). Repeatedly pressing the RST button will cycle through the available timer ranges as shown in the table. When the desired timer range is displayed, press PGM to load the range and return to operating mode. (The CUB7T will remain in Program Mode until the PGM button is pressed.) Remove the wire from the HS (Program Enable) terminal to prevent accidental changes to the timer range. Any new time accumulated will be at the new rate selected.

Note: To avoid incorrect display information, it is recommended that the CUB7T be reset after making programming changes.

DISPLAY DURING PROGRAMMING	Timer Range
00000.000	0.001 Sec
111111.11	0.01 Sec
2222222.2	0.1 Sec
33333333	1 Sec
4444444.4	0.1 Min
55555555	1 Min
666666.66	0.01 Hr
7777777.7	0.1 Hr
88888888	1 Hr
9999.99.99	Factory Use Only

INSTALLATION

The CUB7T meets NEMA 4X/IP65 requirements for indoor use when properly installed. The units are intended to be mounted into an enclosed panel. The viewing window and reset button are factory sealed for a washdown environment. A sponge rubber gasket and mounting clip are provided for installing the unit in the panel cut-out.

Installation Environment

The unit should be installed in a location that does not exceed the maximum operating temperature and provides good air circulation. Placing the unit near devices that generate excessive heat should be avoided.

The bezel should be cleaned only with a soft cloth and neutral soap product. Do NOT use solvents.

Continuous exposure to direct sunlight may accelerate the aging process of the bezel.

Do not use tools of any kind (screwdrivers, pens, pencils, etc.) to operate the push buttons of the unit.

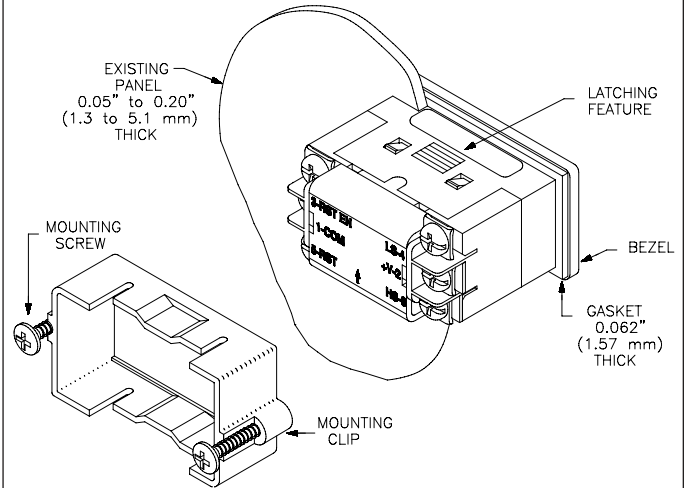

The following procedure assures proper installation:

1. Cut panel opening to specified dimensions. Remove burrs and clean around panel opening.
2. Carefully remove and discard the center section of the gasket.
3. Slide the panel gasket over the rear of the counter body to the back of the bezel. Install CUB7T unit through the panel cut-out.
4. Insert the mounting screws onto both sides of mounting clip. Tip of screw should NOT project from hole in mounting clip.
5. Slide the mounting clip over the rear of the unit until the clip is against the back of the panel. The mounting clip has latching features which engage into mating features on the CUB7T housing.
6. Note: It is necessary to hold the unit in place when sliding mounting clip into position.
7. Alternately tighten each screw to ensure uniform gasket pressure. Visually inspect the front panel gasket. The gasket should be compressed to about 75 to 80% of its original thickness. If not, gradually turn mounting screws to further compress gasket.
8. If the gasket is not adequately compressed and the mounting screws can no longer be turned, loosen mounting screws, and check that the mounting clip is latched as close as possible to the panel.
9. Repeat from step #5 for tightening mounting screws.

BATTERY INSTALLATION

1. Remove all power to the unit before removing battery cover.
2. To remove the battery cover, push upward in the direction of the arrow on the rear cover (See drawing at right), until the cover unlatches. Pull the cover straight out from unit to fully remove.
3. Remove old battery* and replace it with an RLC battery (BNL10000). Observe proper polarity when replacing the battery as shown in the drawing.
4. Replace the cover. The battery cover is keyed so that it cannot be placed upside down. The arrow on the rear of the cover should point toward the top of the CUB7T when properly installed.

* - Dispose of properly.



WARNING: Lithium battery may explode if incinerated.

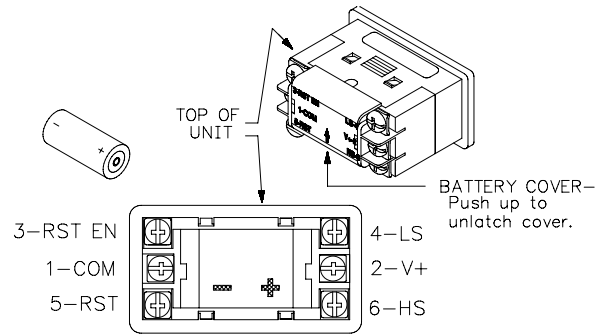

EMC INSTALLATION GUIDELINES

Although this unit is designed with a high degree of immunity to ElectroMagnetic Interference (EMI), proper installation and wiring methods must be followed to ensure compatibility in each application. The type of the electrical noise, source or coupling method into the unit may be different for various installations. In extremely high EMI environments, additional measures may be needed. The unit becomes more immune to EMI with fewer I/O connections. Cable length, routing and shield termination are very important and can mean the difference between a successful or a troublesome installation. Listed below are some EMC guidelines for successful installation in an industrial environment.

1. Use shielded (screened) cables for all Signal and Control inputs. The shield (screen) pigtail connection should be made as short as possible. The connection point for the shield depends somewhat upon the application. Listed below are the recommended methods of connecting the shield, in order of their effectiveness.
 - a. Connect the shield only at the panel where the unit is mounted to earth ground (protective earth).
 - b. Connect the shield to earth ground at both ends of the cable, usually when the noise source frequency is above 1 MHz.
 - c. Connect the shield to common of the unit and leave the other end of the shield unconnected and insulated from earth ground.
2. Never run Signal or Control cables in the same conduit or raceway with AC power lines, conductors feeding motors, solenoids, SCR controls, and heaters, etc. The cables should be run in metal conduit that is properly grounded. This is especially useful in applications where cable runs are long and portable two-way radios are used in close proximity or if the installation is near a commercial radio transmitter.
3. Signal or Control cables within an enclosure should be routed as far away as possible from contactors, control relays, transformers, and other noisy components.
4. In extremely high EMI environments, the use of external EMI suppression devices, such as ferrite suppression cores, is effective. Install them on Signal and Control cables as close to the unit as possible. Loop the cable through the core several times or use multiple cores on each cable for additional protection. Install line filters on the power input cable to the unit to suppress power line interference. Install them near the power entry point of the enclosure. The following EMI suppression devices (or equivalent) are recommended:

Ferrite Suppression Cores for signal and control cables:

Fair-Rite # 0443167251 (RLC #FCOR0000)

TDK # ZCAT3035-1330A

Steward #28B2029-0A0

Line Filters for input power cables:

Schaffner # FN610-1/07 (RLC #LFIL0000)

Schaffner # FN670-1.8/07

Corcom #1VR3

Note: Reference manufacturer's instructions when installing a line filter.

5. Long cable runs are more susceptible to EMI pickup than short cable runs. Therefore, keep cable runs as short as possible.

WIRING CONNECTIONS

The electrical connections are made via screw-clamp terminals located on the back of the unit. All conductors should meet voltage and current ratings for each terminal. Also, cabling should conform to appropriate standards of good installation, local codes and regulations. It is recommended that power supplied to the unit be protected by a fuse or circuit breaker. When wiring the unit, use the battery cover to identify the wire position with the proper function. Strip the wire, leaving approximately 1/4" bare wire exposed (stranded wires should be tinned with solder). Insert the wire under the screw-clamp and tighten down the screw until the wire is clamped in tightly. Each terminal can accept up to two #14 AWG wires.

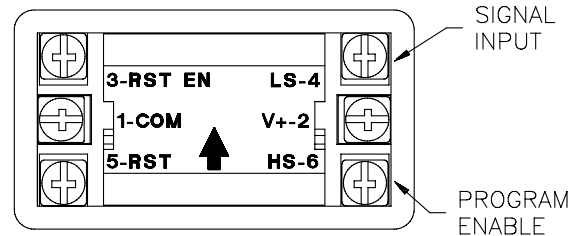

WARNING: Lithium battery may explode if incinerated.



CAUTION: All leads will be at the same line potential as the input leads.

L.S. INPUT; VOLTAGE VERSIONS

The CUB7T accepts most machine control voltage signals. The input accepts AC (50/60 Hz) or DC control voltages from 10 to 300 V. The unit times when voltage is applied between the LS input and Common. *Any off-state leakage current may activate the timer.*



WARNING: Any lead may be at hazardous live input potential. External wiring and devices connected to the unit must be rated the same as applied signal input voltage and be properly isolated from Class 2 or SELV circuitry.

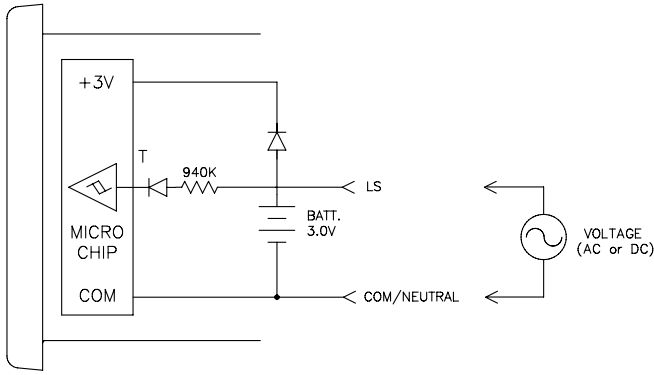

RESET AND PROGRAM OPTIONS

Connecting a wire from the RST EN (Reset Enable) or the HS (Program Enable) Input terminals to Common will enable the front panel Reset or Program buttons respectively.

Pulling the "RST." input low causes the timer to reset. The "RST." can be pulled low by either a mechanical switch or solid-state transistor switch. The Switch load is 15 μ A (max. voltage drop 0.5 V) when ON. The OFF-state leakage current must be less than 2 μ A.

Note: The RC protection circuit on the "RST." Input causes a delay of approximately 15 msec in Reset response.

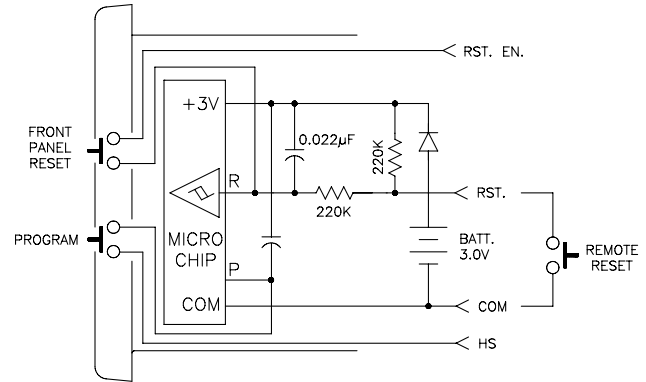

BACKLIGHT OPTION

Optional backlight versions of the CUB7T require an external 9 to 26 VDC power supply. The external supply is connected between the V+ and common terminals as shown in the drawing.



WARNING: When connecting the wiring for a backlit CUB7T measuring an AC input voltage, the neutral of the single phase AC signal is connected to Terminal 1 (COM), and line (hot) is connected to Terminal 4 (LS). The DC supply for the backlighting is connected as shown in the drawing. Three phase AC applications require an isolation transformer.

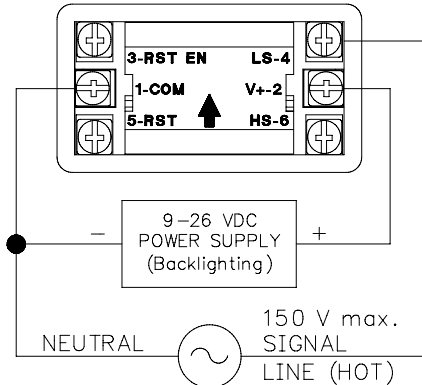

APPLICATION

A laundromat owner wants to monitor the cost of operating his dryers. He needs to know how many hours each dryer has operated. A CUB7T100 (Voltage Input; Positive Image Reflective) is mounted on the back panel of each dryer. The signal input is connected across the motor of the dryer. The CUB7T will accumulate time while the dryer is running. On a regular basis the owner records the cumulative operating hours for each dryer and calculates if he needs to make any necessary adjustments. The timer can be reset via key switch.

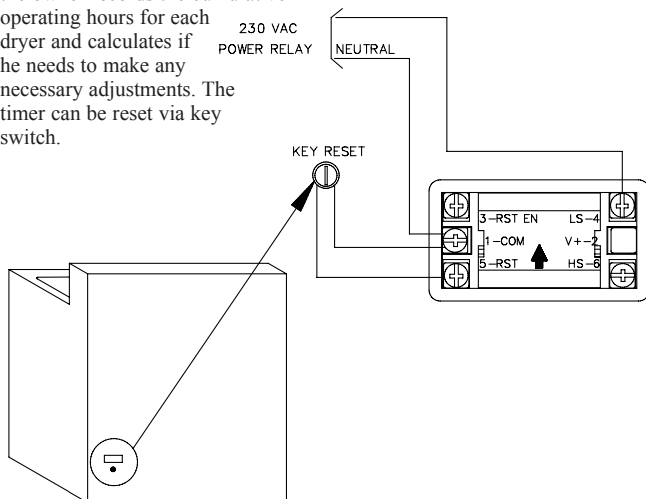

TROUBLESHOOTING

For further technical assistance, contact technical support at the appropriate company numbers listed.

ORDERING INFORMATION

MODEL NO.	DESCRIPTION		PART NUMBER
*CUB7T	VOLTAGE INPUT	Timer; Positive Image Reflective	CUB7T100
		Timer, w/Yel-Grn Backlighting	CUB7T110
		Timer; w/Red Backlighting	CUB7T120
BNL		Replacement 3 V Lithium Battery	BNL10000

*Battery is included with unit.