

## DESCRIPTION

The IF-E97 is a high-optical-output, visible red LED housed in a “connector-less” style plastic fiber optic package. The output spectrum is produced by a GaAlAs die which peaks at 650 nm, one of the optimal transmission windows of PMMA plastic optical fiber. The device package features an internal micro-lens and a precision-molded PBT housing to ensure efficient optical coupling with standard 1000  $\mu\text{m}$  core plastic fiber cable.

## APPLICATION HIGHLIGHTS

The high output and excellent linearity of the IF-E97 make it suitable for analog and digital data links. The IF-E97 can achieve data rates of 1 Mbps when used with an IF-D96 photologic detector. The visible red light has low attenuation in PMMA plastic fiber and aids in troubleshooting installations. The drive circuit design is simpler than required for laser diodes, making the IF-E97 the lowest cost selection for a variety of analog and digital applications requiring maximum operating distance.

## APPLICATIONS

- Low Cost Analog and Digital Data Links
- Automotive Electronics
- Digitized Audio
- Medical Instruments
- PC-to-Peripheral Data Links
- Robotics Communications
- Motor Controller Triggering
- EMC/EMI Signal Isolation
- Local Area Networks
- Intra-System Links: Board-to-Board, Rack-to-Rack

## FEATURES

- ◆ High Optical Power
- ◆ Visible Red Output Aids Troubleshooting
- ◆ Low Transmission Loss with PMMA Plastic Fiber
- ◆ No Optical Design required
- ◆ Mates with standard 1000  $\mu\text{m}$  Core, 2.2 mm Jacketed Plastic Fiber Cable
- ◆ Mates with 2.2 mm Jacketed Multimode Glass Fiber, 200/230 or 400/430 using Active Device Adapter – 51 0537; 51 0538
- ◆ Internal Micro-Lens for Efficient Optical Coupling
- ◆ Inexpensive Plastic Connector Housing
- ◆ Connector-Less Fiber Termination
- ◆ Light-Tight Housing Provides Interference-Free Transmission
- ◆ RoHS compliant

## MAXIMUM RATINGS

( $T_A = 25^\circ\text{C}$ )

Operating and Storage Temperature Range ( $T_{OP}$ , $T_{STG}$ ).....	-40° to 85°C
Junction Temperature ( $T_J$ ).....	85°C
Soldering Temperature (2mm from case bottom) ( $T_S$ ) $t \leq 5$ s.....	240°C
Reverse Voltage ( $V_R$ ).....	5 V
Power Dissipation ( $P_{TOT}$ ) $T_A = 25^\circ\text{C}$ .....	100 mW
De-rate Above 25°C.....	1.33 mW/°C
Forward Current, DC ( $I_F$ ).....	40 mA
Surge Current ( $I_{FSM}$ ) $t \leq 100 \mu\text{s}$ .....	200 mA

## CHARACTERISTICS ( $T_A = 25^\circ\text{C}$ )

Parameter	Symbol	Min.	Typ.	Max.	Unit
Peak Wavelength	$\lambda_{PEAK}$	640	650	660	nm
Full-Spectral Bandwidth (FWHM)	$\Delta\lambda$	–	20	–	nm
Output Power Coupled into Plastic Fiber (1 mm core diameter). Distance Lens to Fiber $\leq 0.1$ mm, 1m polished fiber, $I_F = 20$ mA	$P_O$	200 -7.0	300 -5.2	425 -3.7	$\mu\text{W}$ dBm
Output Power Coupled into Glass Fiber (200/230 $\mu\text{m}$ core) Distance Lens to Fiber $\leq 0.1$ mm, 1 meter BC04265-10 fiber, $I_F = 20$ mA	$P_O$	–	16.93 -17.71	–	$\mu\text{W}$ dBm
Fiber Transmission Loss SH4001 10 meter cutback	L	–	0.19	–	dB/m
Switching Times (10% to 90% and 90% to 10%) (Figure 4)	$t_r$	–	100	–	ns
	$t_f$	–	160	–	ns
Capacitance ( $F = 1$ MHz) ( $V_F = 0$ )	$C_0$	–	20	–	pF
Forward Voltage ( $I_F = 20$ mA)	$V_f$	1.7	1.9	2.1	V

**CAUTION:** The IF E97 is ESD sensitive. To minimize risk of damage observe appropriate precautions during handling and processing.

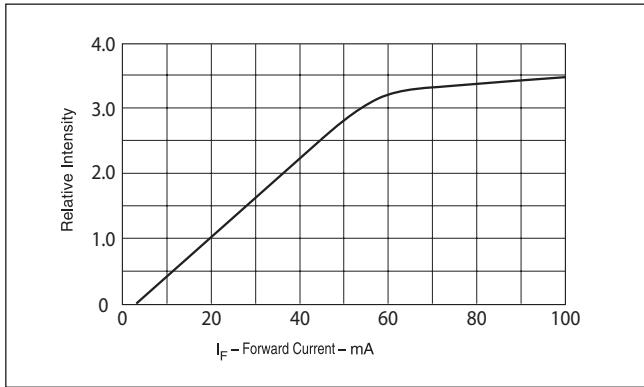

FIGURE 1. Normalized power launched versus forward current.

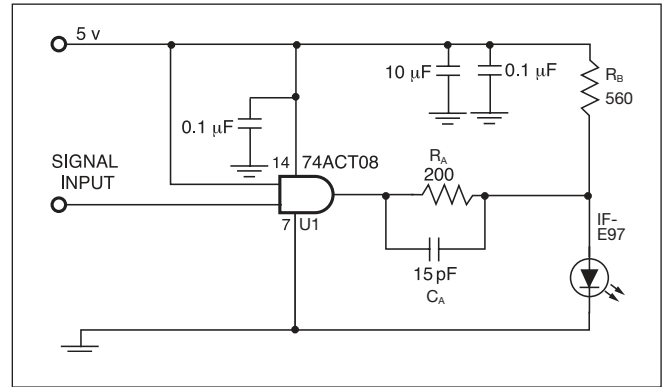

FIGURE 4. Test/Application circuit (IF = 20mA).

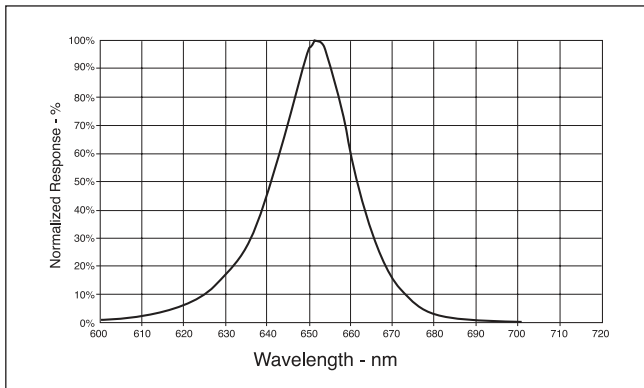

FIGURE 2. Typical spectral output versus wavelength.

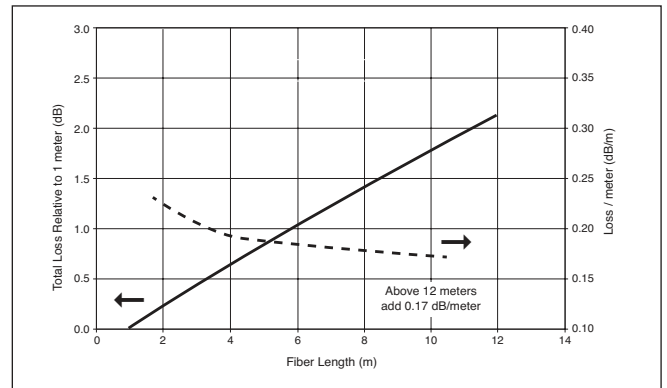

FIGURE 5. Fiber Loss in GH4001

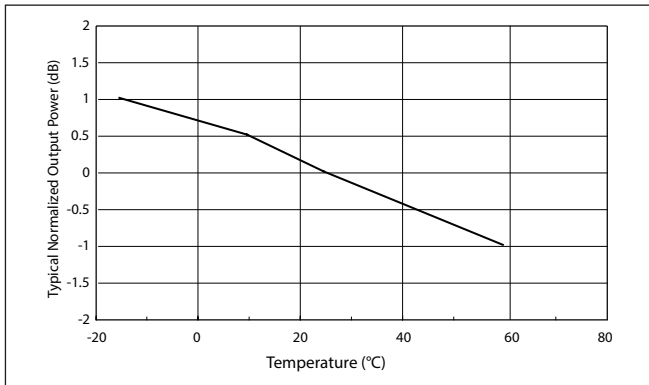

FIGURE 3. Output power versus temperature

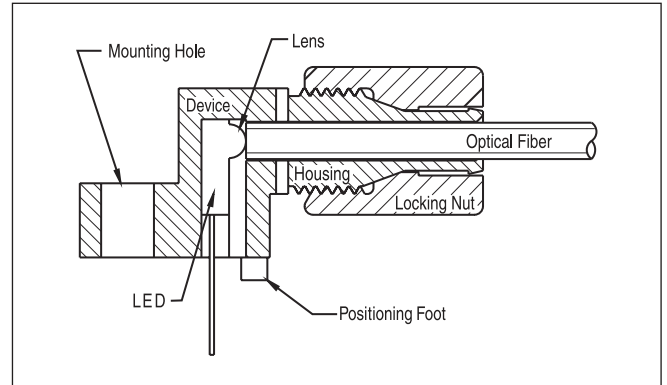

FIGURE 6. Cross-section of fiber optic device.

## APPLICATION NOTES

The application circuit given in Figure 4 can be used to drive the IF-E97 for fast applications. Gate U1 represents the circuit being used to drive the IF-E97. This must be able to supply the desired drive current at the output voltage. Resistor  $R_A$  supplies most of the drive current for the IF-E97. The amount of current supplied is  $I_A = (V_{U1} - V_f) / R_A$ , where  $V_f$  is the IF-E97 forward voltage and  $V_{U1}$  is the drive circuit's output voltage under load. Resistor  $R_B$  speeds up the switching time by keeping the voltage across the IF-E97 from going to zero during turn off. It also supplies some of the drive current. The drive current from  $R_B$  is  $I_B = (V_{CC} - V_f) / R_B$ , where  $V_{CC}$  is the supply voltage. The total drive current to the IF-E97 is  $I_A + I_B$ . Some power is wasted in  $R_B$  when the IF-E97 is off. Capacitor  $C_A$  is used to increase the drive current during switching and speed up the turn on and turn off times. It must not be so large as to overdrive the IF-E97 during turn on or drive the voltage negative during turn off. For lower speed applications, only  $R_A$  is needed and  $C_A$  and  $R_B$  can be omitted.

## FIBER TERMINATION INSTRUCTIONS – PLASTIC OPTICAL FIBER

1. Cut off the ends of the optical fiber with a single-edge razor blade or sharp knife. Try to obtain a precise 90-degree angle (square).
2. Insert the fiber through the locking nut and into the connector until the core tip seats against the internal micro-lens.
3. Screw the connector locking nut down to a snug fit, locking the fiber in place. Do not exceed a torque of 0.4 N·m.

*Glass fiber – Refer to instructions listed on manufacturer's data sheet for each active device adapter.*

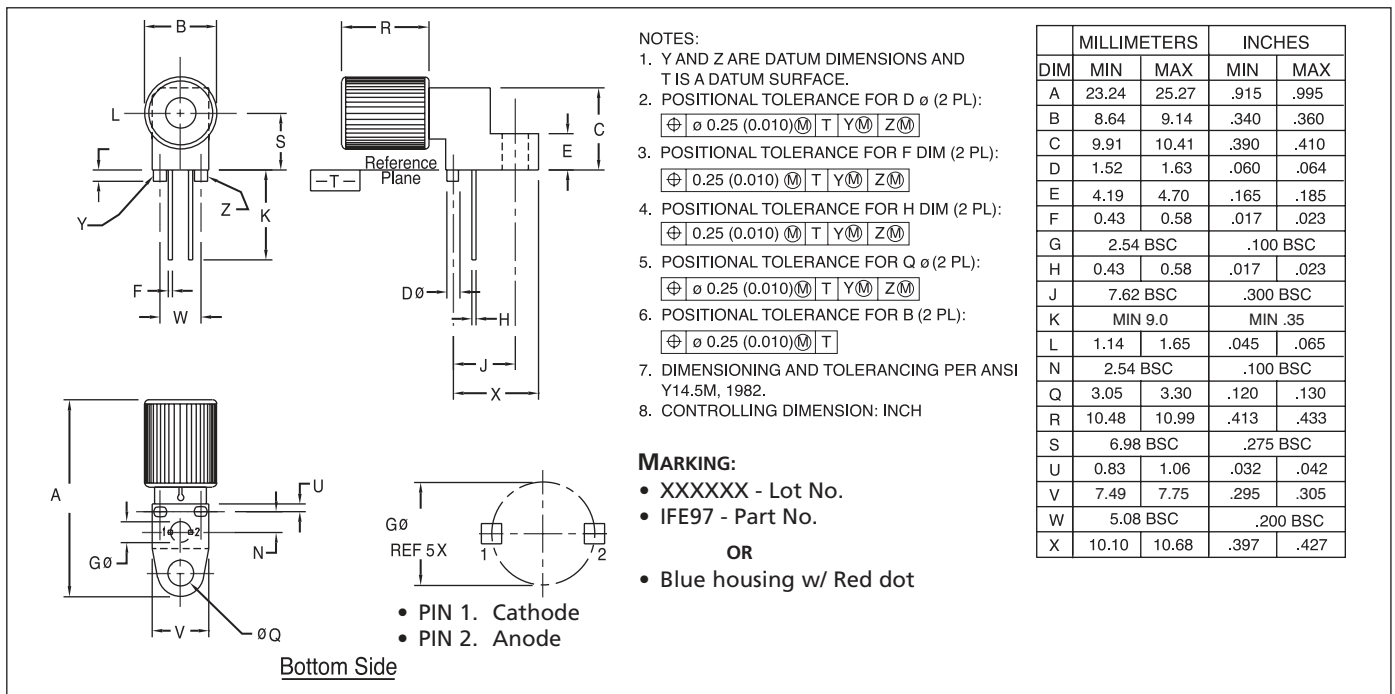

**FIGURE 7.** Case outline. Specifications are believed to be accurate but are subject to change. Industrial Fiber Optics assumes no responsibility for the consequences of using the information provided beyond replacement warranty for products not meeting stated specifications. Industrial Fiber Optics products are not authorized for use in life support applications without written approval from the President of Industrial Fiber Optics Corporation.

**CAUTION:**

- To avoid degraded device life due to package stress, do not bend or form leads outside the orientation shown on drawing.
- Ensure that solder flux does not migrate into the device and block the optical path, degrading the performance.
- If washing the device, liquid may become trapped in the part cavity. Ensure that all potentially corrosive materials are flushed out of the device.