

| ATLANTIC VERSION TERMINATOR INTERFACE ADAPTER | PART NUMBER | REVISION | DESCRIPTION | FEED TYPE | CONVERT TO | PART NUMBERS REQUIRED | | | | | |
|---|-------------|--------------------------|--------------------------------|--------------------------------|-------------------|-----------------------|-----------|-------------|-----------|-------------|------------------------|
| | 2151998-1 | A | FINE CRIMP HEIGHT ADJUST | MECHANICAL | PNEUMATIC FEED | 2119950-1 | 1338685-1 | 5-18022-5 | 2119641-1 | 2119799-1 | 2063440-1 |
| | 2151998-2 | A | FINE CRIMP HEIGHT ADJUST | PNEUMATIC | SERVO LATCH PLATE | 2119951-1 | - | 8-2151998-5 | 1901094-3 | 1-1752354-7 | 2168400-6 (QUANTITY 2) |
| | | | | | SMART APPLICATOR | 2161326-1 | - | 8-2151998-4 | - | - | |
| | | | | | MECHANICAL FEED | 2119949-1 | 1338685-1 | 5-18022-5 | 2119653-1 | - | - |
| | 2151998-5 | A | FINE CRIMP HEIGHT ADJUST | SERVO LATCH PLATE ⁴ | SERVO LATCH PLATE | 2119951-1 | - | 8-2151998-5 | 1901094-3 | 1-1752354-7 | 2168400-6 (QUANTITY 2) |
| | | | | | SMART APPLICATOR | 2161326-1 | - | 8-2151998-4 | - | - | |
| | | | | | MECHANICAL FEED | 2119949-1 | 1338685-1 | 5-18022-5 | 2119653-1 | - | - |
| 2151998-6 | A | NON-CRIMP HEIGHT ADJUST | SERVO LATCH PLATE ⁴ | - | - | - | - | - | - | - | |
| 2151998-7 | A | FINE CRIMP HEIGHT ADJUST | NONE | - | - | - | - | - | - | - | |
| 7-2151998-7 | A | CRIMP TOOLING KIT | - | - | - | - | - | - | - | - | |

| APPLICATOR DATA | | |
|-----------------|----------------|------|
| CRIMP | SIZE | TYPE |
| WIRE | 1.07 mm [.042] | F |
| INSUL | 1.40 mm [.055] | F |

APPLICATOR INSTRUCTIONS
408-10389

| TERMINAL DATA: TE TERMINAL | | TE CRIMP SPECIFICATION | |
|--|-------------|------------------------------|-------------|
| TERMINAL NAME: RECEPTACLE CONTACT SDL2.0MM PITCH CONNECTOR | | | |
| WIRE STRIP LENGTH | | INSULATION DIAMETER RANGE | |
| 2.20-2.80 mm [.087-.110 IN] | | Ø0.80-1.50 mm [.031-.059 IN] | |
| TERMINAL APPLICATION SPECIFICATION | 114-106140 | | |
| TERMINALS APPLIED ³ | | | |
| TE TERMINAL | TE TERMINAL | TE TERMINAL | TE TERMINAL |
| 2232215-1 | 2232215-2 | 2232215-3 | |

| WIRE SIZE | CRIMP HEIGHT mm [INCH] | CRIMP HEIGHT REFERENCE SETTING |
|-----------|----------------------------|--------------------------------|
| 22 AWG | 0.77+/-0.04 [.030+/-0.002] | 8.9 |
| 24 AWG | 0.67+/-0.04 [.026+/-0.002] | 9.9 |
| 26 AWG | 0.61+/-0.04 [.024+/-0.002] | 10.5 |
| 28 AWG | 0.57+/-0.03 [.022+/-0.001] | 10.9 |

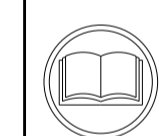

- 1 RECOMMENDED SPARE PARTS
- 2 GREASE BEARING SURFACES LIGHTLY
- 3 LUBRICATE DAILY PER THE APPLICATOR INSTRUCTION SHEET SUPPLIED WITH THE APPLICATOR.
- 4 APPLICATOR SPECIFIC DATA TO BE ENTERED INTO BLANK MEMORY CHIP AT ASSEMBLY. SEE BELOW FOR PART NUMBER:
 MECHANICAL FEED WITH "SMART APPLICATOR" CONVERSION: 8-2151998-4
 PNEUMATIC FEED WITH "SMART APPLICATOR" CONVERSION: 8-2151998-4
 SERVO FEED WITH "FINE CRIMP HEIGHT ADJUST": 8-2151998-5
 SERVO FEED WITH "NON-CRIMP HEIGHT ADJUST": 8-2151998-6
- 5 ADJUSTMENT OF THE STRIPPER MAY BE REQUIRED WHEN MOVING THE APPLICATOR BETWEEN BENCH AND LEADMAKER APPLICATIONS.
- 6 APPLY PART NUMBER 1-23419-5 LOCTITE TO THREADS OF ITEMS 62 & 242. FOR -6 ONLY APPLY PART NUMBER 1-23419-5 LOCTITE TO THREADS OF ITEMS 37 & 242.
- 7 GREASE THREADS, GROOVE AND O-RING ON ITEMS 35 & 252.
- 8 MAGNET, ITEM 166 MUST BE ORIENTED CORRECTLY IN ORDER TO PROPERLY ACTUATE THE COUNTER.
- 9 CRIMP HEIGHT REFERENCE SETTING WAS THE SETTING USED WHEN THE APPLICATOR WAS QUALIFIED AT THE FACTORY. ADJUSTMENT MAY BE NECESSARY WHEN RUNNING APPLICATOR IN THE FIELD.
- 10 SPARE FEED CAM STORAGE LOCATION REFER TO INSTRUCTION SHEET FOR ADDITIONAL INFORMATION.
- 11 TO CONVERT THE APPLICATOR TO A NON-CARRIER CUTTING STYLE, REMOVE ITEM 13 AND ATTACH TO THE LOCATION ON THE BACK SIDE OF THE HOUSING. REFER TO INSTRUCTION SHEET FOR ADDITIONAL INFORMATION.
- 12 WHEN ASSEMBLING A NON CRIMP HEIGHT ADJUST APPLICATOR (-6) USE SHIMS FROM ITEM 260 TO ACHIEVE A NOMINAL SHIM HEIGHT OF 5.03.
- 13 THE TERMINAL AND THE SPEC ARE ALL PRELIMINARY STATUS. THE TERMINAL REV IS 3 AND THE SPEC REV IS 1.

***WARNING**
ON INSTALLATION, SET WIRE DISC, ITEM 40 TO LARGEST WIRE SIZE SETTING. USE OF SETTINGS BELOW MINIMUM REQUIRED CRIMP HEIGHT SETTING WILL CAUSE DAMAGE TO CRIMP TOOLING.

ATLANTIC VERSION
Shown on sheets 1 of 4 & 2 of 4
(Pacific version shown on sheets 3 of 4 & 4 of 4)

| SET UP GAUGE | LOC | DIST | REVISIONS | | | | |
|--------------|-----|------|-----------|-------------|-----------|-----|------|
| 2119599-1 | A | 66 | P. LTM | DESCRIPTION | DATE | OWN | APVD |
| | | | A | RELEASE | 30OCT2013 | L.Z | U.G |

| | | | | | | | | |
|---|-----|-----|-----|-----|-----|-------------|-------------------------------------|-----|
| - | 1 | 1 | 1 | 1 | 1 | 2119791-9 | DEPRESSOR, WIRE | 261 |
| - | - | 1 | - | - | - | 2119957-2 | APPLICATOR SHIM PACK | 260 |
| - | 1 | - | 1 | 1 | 1 | 8-21084-0 | O-RING, .676 ID, .070 DIA. MAT. | 252 |
| - | - | - | - | 1 | - | 2119640-1 | PUSH ROD, AIR FEED | 250 |
| - | - | - | - | 1 | - | 2079988-1 | BUSHING, LCH5-12, MISUMI | 249 |
| - | - | - | - | 1 | - | 2119641-1 | FEED CAM, AIR FEED | 248 |
| - | 1 | - | 1 | 1 | 1 | 2119798-1 | DETENT PIN | 247 |
| - | 1 | - | 1 | 1 | 1 | 1-22279-3 | SPRING, COMPRESSION | 246 |
| - | - | 1 | - | - | - | 2119758-1 | RAM, AMP STYLE, SIDE FEED, NON-ADJ. | 245 |
| - | 1 | 1 | 1 | 1 | 1 | 2119082-9 | CAM, SNAIL, INSULATION ADJUSTMENT | 244 |
| - | 1 | 1 | 1 | 1 | 1 | 2079764-1 | WASHER, WAVE SPRING, CREST-TO-CREST | 243 |
| - | 1 | 1 | 1 | 1 | 1 | 2119083-1 | RETAINER, INSULATION DIAL | 242 |
| - | 1 | 1 | 1 | 1 | 1 | 7-18023-7 | SCR, SKT HD CAP M3 X 4.0 | 241 |
| - | - | 2 | 2 | - | - | 2168400-6 | SHCS, LOW HEAD, RoHS, M5 X 16 | 240 |
| - | - | - | - | - | 1 | 2119580-1 | MECHANICAL FEED ASSEMBLY | 239 |
| - | - | - | - | 1 | - | 2063440-1 | AIR FEED MODULE | 238 |
| - | - | 1 | 1 | - | - | 2119740-2 | TAG, IDENTIFICATION | 213 |
| - | - | 1 | 1 | - | - | 1901094-3 | SPACER, FEEDER | 198 |
| - | - | - | - | 2 | - | 21045-3 | RING, RETAIN, EXTERN, 3/16 CRESCENT | 172 |
| - | 1 | 1 | 1 | 1 | 1 | 994969-1 | MAGNET, RARE EARTH HIGH ENERGY | 166 |
| - | REF | REF | REF | REF | REF | 994970-2 | COUNTER, MAGNETIC | 164 |
| - | - | - | - | 1 | - | 240638-1 | SPRING, FEED FINGER | 163 |
| - | - | - | - | 1 | - | 3-23627-7 | PIN, RETAIN, GRVD, 3/16 X .854 | 137 |
| - | - | - | - | 1 | - | 2119799-1 | HOLDER, FEED FINGER, AF | 136 |
| - | - | REF | REF | - | - | SEE NOTE 4 | MEMORY CHIP, PROGRAMMED | 135 |
| - | - | 1 | 1 | - | - | 1633743-1 | SERVO FEED LATCH ASM | 133 |
| - | 1 | 1 | 1 | 1 | 1 | 1-18028-2 | WASHER, FLAT, REG M4 | 119 |
| - | - | REF | REF | - | - | 2119944-1 | FEED FINGER ASSEMBLY, SF | 117 |
| - | 1 | 1 | 1 | 1 | 1 | 1-455888-4 | SPACER, CRIMPER | 82 |
| - | 1 | 1 | 1 | 1 | 1 | 2119956-1 | DOCUMENTATION PACKAGE | 71 |
| - | 1 | - | - | 1 | 1 | 2119740-1 | TAG, IDENTIFICATION | 67 |
| - | 2 | 2 | 2 | 2 | 2 | 2168078-1 | SCREW, DRIVE, RH, RoHS, 2 x .188 | 66 |
| - | 1 | - | 1 | 1 | 1 | 2119793-1 | LIMITER, ADJUSTMENT BOLT | 63 |
| - | 3 | - | 3 | 3 | 3 | 992763-5 | SCR, SET, SOC, CONE POINT, M3 x 4.0 | 62 |
| - | 1 | 1 | 1 | 1 | 1 | 2079383-4 | SCR, BHSC, RoHS (M4 X 8) | 60 |
| - | - | - | - | 1 | 1 | 5-18022-5 | PAWL, FEED | 59 |
| - | - | - | - | 1 | 1 | 1338685-1 | PAWL, FEED | 56 |
| - | 4 | 4 | 4 | 4 | 4 | 2168400-1 | SHCS, LOW HEAD, RoHS, M4 X 12 | 54 |
| - | - | - | - | 1 | 2 | 18023-9 | SCR, SKT HD CAP M4 X 6.0 | 49 |
| - | - | - | - | - | 1 | 2119652-1 | FEED CAM, PRE FEED | 48 |
| - | - | - | - | - | 1 | 2119653-1 | FEED CAM, POST FEED | 47 |
| - | 1 | 1 | 1 | 1 | 1 | 2119656-9 | APPLICATOR BASIC ASSEMBLY, SF | 46 |
| - | 1 | - | 1 | 1 | 1 | 2119370-1 | RAM, AMP STYLE, SIDE FEED | 44 |
| - | 1 | 1 | 1 | 1 | 1 | 2079383-7 | SCR, BHSC, RoHS (M8 X 25) | 41 |
| - | 1 | - | 1 | 1 | 1 | 2119645-1 | DISC, NUMBERED FA WIRE ADJUSTMENT | 40 |
| - | 1 | - | 1 | 1 | 1 | 2119957-1 | APPLICATOR SHIM PACK | 39 |
| - | 1 | 1 | 1 | 1 | 1 | 2119644-1 | RAM WASHER, PRECISION | 38 |
| - | 1 | 1 | 1 | 1 | 1 | 2119085-1 | FA HEAD, ATLANTIC STYLE | 37 |
| - | 1 | - | 1 | 1 | 1 | 2119092-1 | BOLT, ADJUSTMENT | 35 |
| - | 1 | 1 | 1 | 1 | 1 | 2-1752356-3 | SUPPORT, TERMINAL | 34 |
| - | 2 | 2 | 2 | 2 | 2 | 2079383-5 | SCR, BHSC, RoHS (M4 X 20) | 33 |
| - | 1 | 1 | 1 | 1 | 1 | 2161328-1 | HEX HEAD, FLANGED, M5 x 8mm LONG | 32 |
| - | 1 | 1 | 1 | 1 | 1 | 1320908-2 | SPACER, STRIP GUIDE | 30 |
| - | 1 | 1 | 1 | 1 | 1 | 2119959-1 | ASSEMBLY, STRIP GUIDE | 29 |
| - | 1 | 1 | 1 | 1 | 1 | 455888-6 | SPACER, CRIMPER | 28 |
| - | 1 | 1 | 1 | 1 | 1 | 1320928-2 | STRIP GUIDE | 24 |
| - | 1 | 1 | 1 | 1 | 1 | 2168083-2 | SCR, SKT HD CAP, RoHS, M4 X 8.0 | 21 |
| - | 1 | 1 | 1 | 1 | 1 | 1-18028-2 | WASHER, FLAT, REG M4 | 20 |
| - | 1 | 1 | 1 | 1 | 1 | 2119533-1 | STRIPPER, SIDE FEED | 19 |
| - | 1 | 1 | 1 | 1 | 1 | 2119806-1 | INSERT, SHEAR | 13 |
| - | 1 | 1 | 1 | 1 | 1 | 3-22280-3 | SPRING, COMPRESSION | 12 |
| - | 1 | 1 | 1 | 1 | 1 | 1-356885-4 | STOP, SHEAR | 11 |
| - | 1 | 1 | 1 | 1 | 1 | 2119805-1 | SHEAR HOLDER, FRONT | 10 |
| - | 1 | 1 | 1 | 1 | 1 | 462006-6 | FLOATING SHEAR, FRONT | 9 |
| - | 1 | 1 | 1 | 1 | 1 | 1803079-7 | ANVIL, WITH STABILIZER | 8 |
| - | - | - | - | - | - | - | - | 7 |
| - | - | - | - | - | - | - | - | 6 |
| - | 1 | 1 | 1 | 1 | 1 | 2119757-8 | DEPRESSOR, SHEAR | 5 |
| - | 1 | 1 | 1 | 1 | 1 | 2-238011-0 | BLOCK, CRIMPER SPACER | 4 |
| - | 1 | 1 | 1 | 1 | 1 | 8-2119582-4 | CRIMPER, INSULATION F PREMIUM | 3 |
| - | 1 | 1 | 1 | 1 | 1 | 455888-3 | SPACER, CRIMPER | 2 |
| - | 1 | 1 | 1 | 1 | 1 | 1-456401-3 | CRIMPER, WIRE PREMIUM | 1 |

| DIMENSIONS: | | TOLERANCES UNLESS OTHERWISE SPECIFIED: | | DRAWING NO | | RESTRICTED TO | |
|--|-----------|--|-----------|------------|-----------|---------------|--------|
| mm | 0 PLC ±.5 | 1 PLC ±.5 | 2 PLC ±.5 | 3 PLC ±.5 | 4 PLC ±.5 | ANGLES ±.0001 | FINISH |
| MATERIAL | | | | WEIGHT | | SCALE | |
| Customer Accessible Production Drawing | | | | SCALE 1:2 | | SHEET 1 OF 4 | |

| LOC | | DIST | | REVISIONS | | | |
|-----|----|------|-----|-------------|------|-----|------|
| A | 66 | P | LYN | DESCRIPTION | DATE | DWN | APVD |
| | | - | | SEE SHEET 1 | | | |

FEED TYPE MECHANICAL



PNEUMATIC

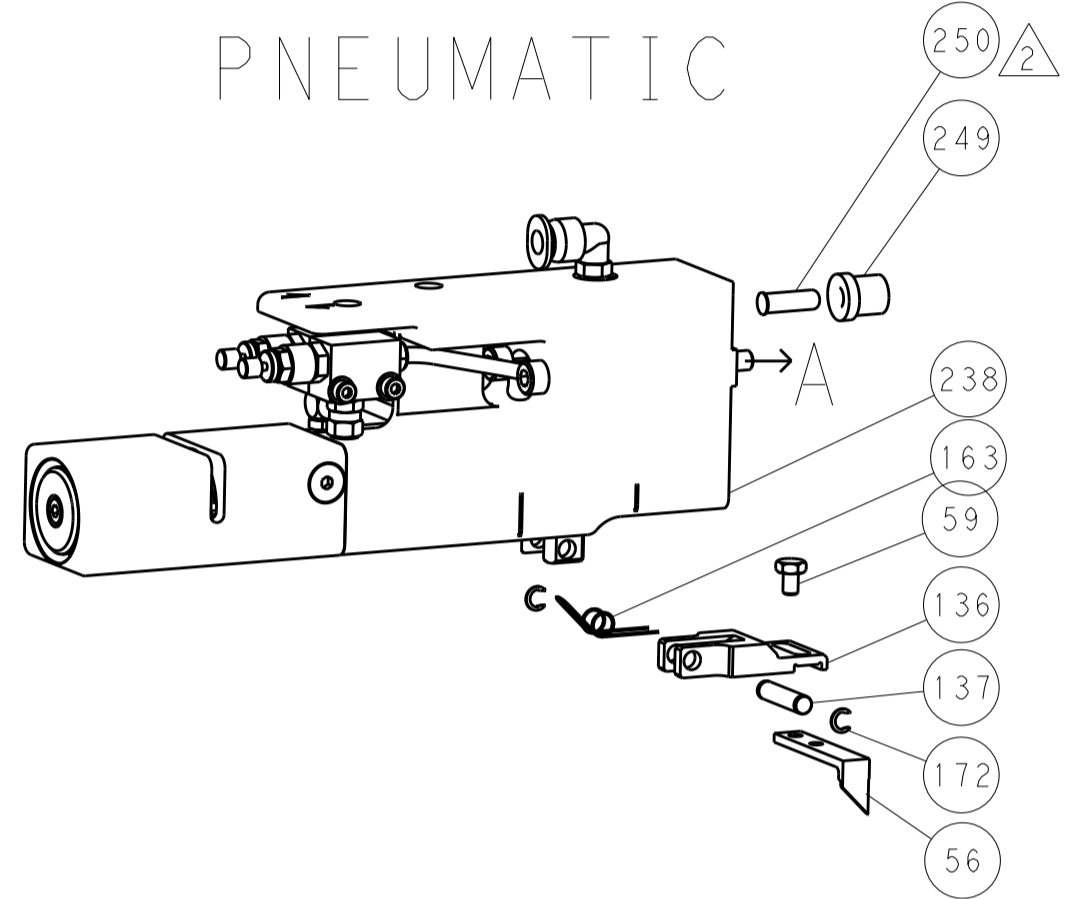

SERVO LATCH PLATE



CAM POSITIONS

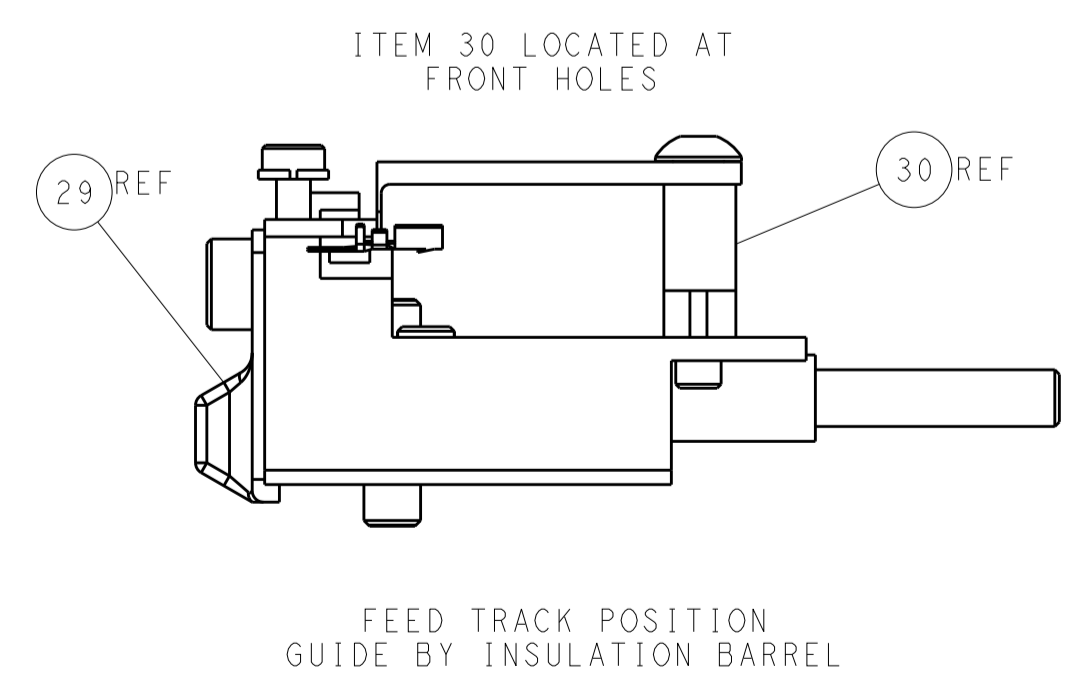
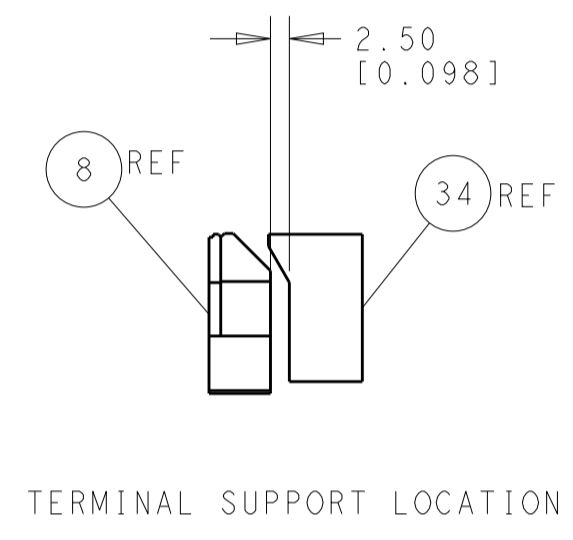
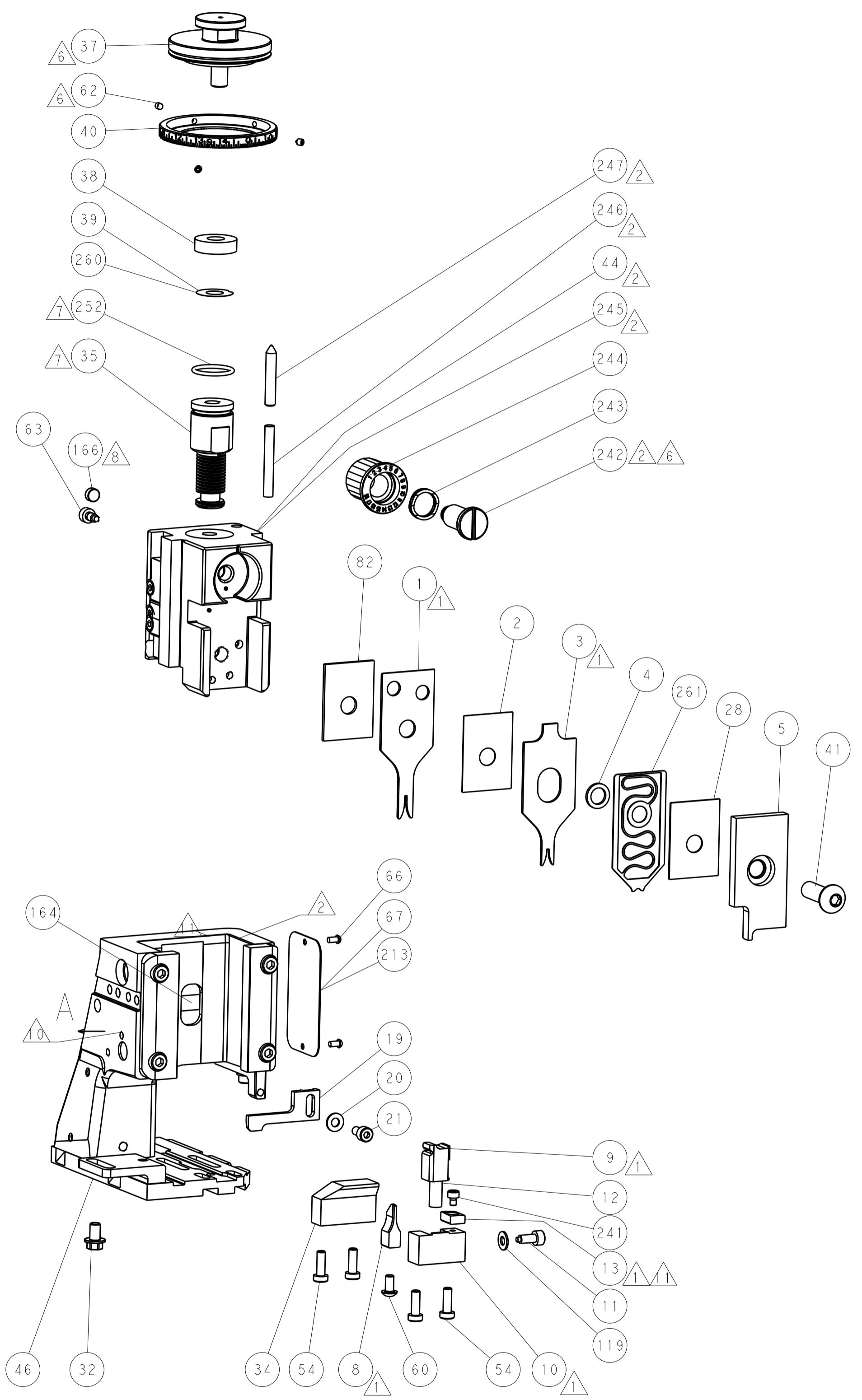
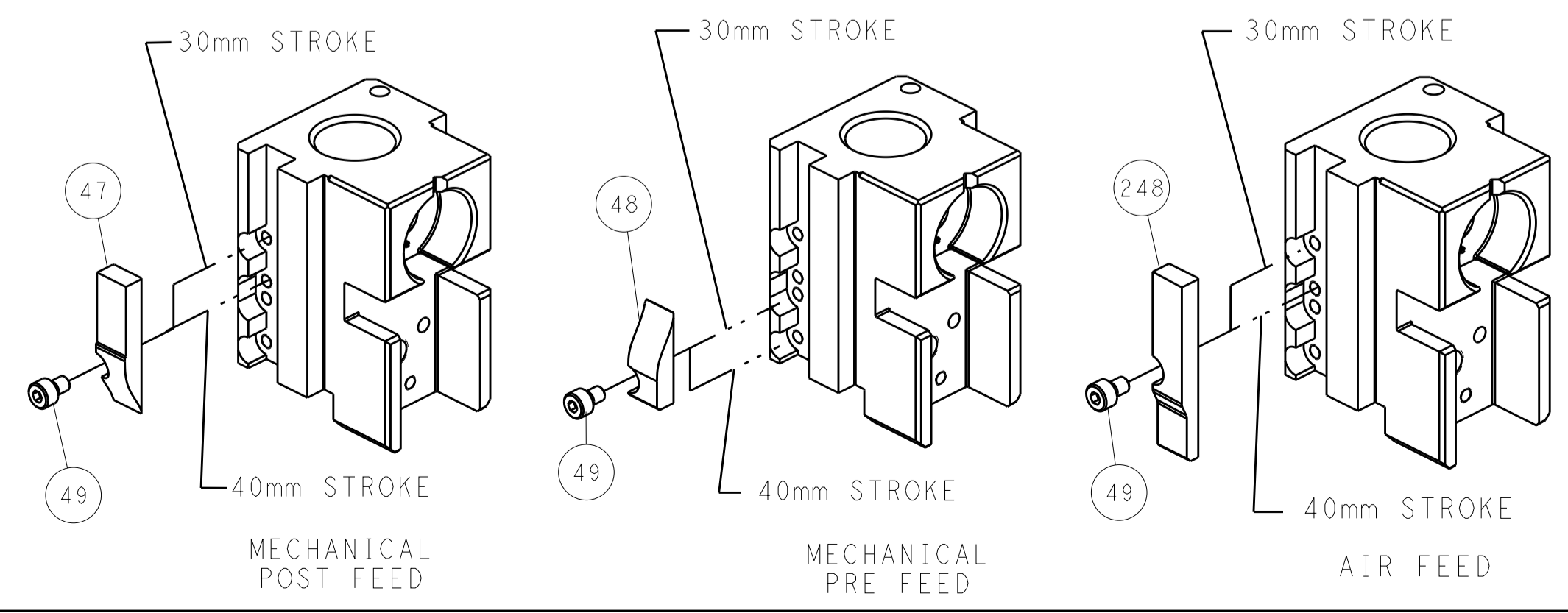

ATLANTIC VERSION
 Shown on sheets 1 of 4 & 2 of 4
 (Pacific version shown on sheets 3 of 4 & 4 of 4)

| | | | | | | | |
|-------------|------------|--|-------------|----------------------------------|--------------|------------------------|---------------------------|
| DIMENSIONS: | | TOLERANCES UNLESS OTHERWISE SPECIFIED: | | DWN: C. CHEN 24JUL2013 | | TE Connectivity | |
| mm | 0 PLC ±0.5 | 1 PLC ±0.5 | 2 PLC ±0.13 | 3 PLC ±0.013 | 4 PLC ±0.001 | APVD: U. GUO 24JUL2013 | Harrisburg, PA 17105-3608 |
| MATERIAL: | | FINISH: | | NAME: Ocean Side Feed Applicator | | RESTRICTED TO: | |
| | | | | SIZE: A1 | | CAGE CODE: 00779 | |
| | | | | DRAWING NO: 2151998 | | SCALE: 1:2 | |
| | | | | SHEET: 2 of 4 | | REV: A | |

| PACIFIC VERSION TERMINATOR INTERFACE ADAPTER | PART NUMBER | REVISION | DESCRIPTION | FEED TYPE | APPLICATOR STYLE CONVERSION CHART | | | | | | |
|--|-------------|----------|--------------------------|-------------------|-----------------------------------|-----------------------|-----------|-------------|-----------|-------------|------------------------|
| | | | | | CONVERT TO | PART NUMBERS REQUIRED | | | | | |
| | 2-2151998-1 | A | FINE CRIMP HEIGHT ADJUST | MECHANICAL | PNEUMATIC FEED | 2119950-1 | 1338685-1 | 5-18022-5 | 2119641-2 | 2119799-1 | 2063440-1 |
| | | | | | SERVO LATCH PLATE | 2119951-1 | - | 8-2151998-5 | 1901094-3 | 1-1752354-7 | 2168400-6 (QUANTITY 2) |
| | | | | | SMART APPLICATOR | 2161326-1 | - | 8-2151998-4 | - | - | - |
| | 2-2151998-2 | A | FINE CRIMP HEIGHT ADJUST | PNEUMATIC | MECHANICAL FEED | 2119949-1 | 1338685-1 | 5-18022-5 | 2119653-2 | - | - |
| | | | | | SERVO LATCH PLATE | 2119951-1 | - | 8-2151998-5 | 1901094-3 | 1-1752354-7 | 2168400-6 (QUANTITY 2) |
| | | | | | SMART APPLICATOR | 2161326-1 | - | 8-2151998-4 | - | - | - |
| | 2-2151998-5 | A | FINE CRIMP HEIGHT ADJUST | SERVO LATCH PLATE | MECHANICAL FEED | 2119949-1 | 1338685-1 | 5-18022-5 | 2119653-2 | - | - |
| | | | | | PNEUMATIC FEED | 2119950-1 | 1338685-1 | 5-18022-5 | 2119641-2 | 2119799-1 | 2063440-1 |
| | 2-2151998-7 | A | FINE CRIMP HEIGHT ADJUST | NONE | - | - | - | - | - | - | - |
| | 7-2151998-7 | A | CRIMP TOOLING KIT | - | - | - | - | - | - | - | - |

| APPLICATOR DATA | | |
|--------------------------------------|----------------|------|
| CRIMP | SIZE | TYPE |
| WIRE | 1.07 mm [.042] | F |
| INSUL | 1.40 mm [.055] | F |
| APPLICATOR INSTRUCTIONS 408-10389 | | |

| TERMINAL DATA: TE TERMINAL | | TE CRIMP SPECIFICATION | |
|--|-------------|------------------------------|-------------|
| TERMINAL NAME: RECEPTACLE CONTACT SDL2.0MM PITCH CONNECTOR | | | |
| WIRE STRIP LENGTH | | INSULATION DIAMETER RANGE | |
| 2.20-2.80 mm [.087-.110 IN] | | Ø0.80-1.50 mm [.031-.059 IN] | |
| TERMINAL APPLICATION SPECIFICATION | 114-106140 | | |
| TERMINALS APPLIED | | | |
| TE TERMINAL | TE TERMINAL | TE TERMINAL | TE TERMINAL |
| 2232215-1 | 2232215-2 | 2232215-3 | |

| WIRE SIZE | CRIMP HEIGHT mm [INCH] | CRIMP HEIGHT REFERENCE SETTING |
|-----------|----------------------------|--------------------------------|
| 22 AWG | 0.77+/-0.04 [.030+/-0.002] | 8.9 |
| 24 AWG | 0.67+/-0.04 [.026+/-0.002] | 9.9 |
| 26 AWG | 0.61+/-0.04 [.024+/-0.002] | 10.5 |
| 28 AWG | 0.57+/-0.03 [.022+/-0.001] | 10.9 |

- RECOMMENDED SPARE PARTS
- GREASE BEARING SURFACES LIGHTLY
- LUBRICATE DAILY PER THE APPLICATOR INSTRUCTION SHEET SUPPLIED WITH THE APPLICATOR.
- APPLICATOR SPECIFIC DATA TO BE ENTERED INTO BLANK MEMORY CHIP AT ASSEMBLY. SEE BELOW FOR PART NUMBER:
 MECHANICAL FEED WITH "SMART APPLICATOR" CONVERSION: 8-2151998-4
 PNEUMATIC FEED WITH "SMART APPLICATOR" CONVERSION: 8-2151998-4
 SERVO FEED WITH "FINE CRIMP HEIGHT ADJUST": 8-2151998-5
- ADJUSTMENT OF THE STRIPPER MAY BE REQUIRED WHEN MOVING THE APPLICATOR BETWEEN BENCH AND LEADMAKER APPLICATIONS.
- APPLY PART NUMBER 1-23419-5 LOCTITE TO THREADS OF ITEMS 62 & 242.
- GREASE THREADS, GROOVE AND O-RING ON ITEMS 139 & 152.
- MAGNET MUST BE ORIENTED CORRECTLY IN ORDER TO PROPERLY ACTUATE THE COUNTER.
- CRIMP HEIGHT REFERENCE SETTING WAS THE SETTING USED WHEN THE APPLICATOR WAS QUALIFIED AT THE FACTORY. ADJUSTMENT MAY BE NECESSARY WHEN RUNNING APPLICATOR IN THE FIELD.
- SPARE FEED CAM STORAGE LOCATION REFER TO INSTRUCTION SHEET FOR ADDITIONAL INFORMATION.
- TO CONVERT THE APPLICATOR TO A NON-CARRIER CUTTING STYLE, REMOVE ITEM 13 AND ATTACH TO THE LOCATION ON BACK SIDE OF THE HOUSING. REFER TO INSTRUCTION SHEET FOR ADDITIONAL INFORMATION.
- THE TERMINAL AND THE SPEC ARE ALL PRELIMINARY STATUS. THE TERMINAL REV IS 3 AND THE SPEC REV IS 1.

***WARNING**
 ON INSTALLATION, SET WIRE DISC, ITEM 40 TO LARGEST WIRE SIZE SETTING. USE OF SETTINGS BELOW MINIMUM REQUIRED CRIMP HEIGHT SETTING WILL CAUSE DAMAGE TO CRIMP TOOLING.

PACIFIC VERSION
 Shown on sheets 3 of 4 & 4 of 4
 (Atlantic version shown on sheets 1 of 4 & 2 of 4)

| SET UP GAUGE | LOC | DIST | REVISIONS | | | |
|--------------|-----|------|-----------|-------------|----|------|
| 2119599-1 | A | 66 | REV | DATE | BY | APPV |
| | | | - | SEE SHEET 1 | - | - |

| | | | | | | | |
|---|-----|-----|-----|-----|-------------|-------------------------------------|-----|
| - | 1 | 1 | 1 | 1 | 2119791-9 | DEPRESSOR, WIRE | 261 |
| - | 1 | 1 | 1 | 1 | 2119782-1 | FINE ADJUST HEAD ASM, PACIFIC STYLE | 251 |
| - | - | - | 1 | - | 2119640-1 | PUSH ROD, AIR FEED | 250 |
| - | - | - | 1 | - | 2079988-1 | BUSHING, LCH5-12, MISUMI | 249 |
| - | 1 | 1 | 1 | 1 | 1-22279-3 | SPRING, COMPRESSION | 246 |
| - | 1 | 1 | 1 | 1 | 2119082-9 | CAM, SNAIL, INSULATION ADJUSTMENT | 244 |
| - | 1 | 1 | 1 | 1 | 2079764-1 | WASHER, WAVE SPRING, CREST-TO-CREST | 243 |
| - | 1 | 1 | 1 | 1 | 2119083-1 | RETAINER, INSULATION DIAL | 242 |
| - | 1 | 1 | 1 | 1 | 7-18023-7 | SCR, SKT HD CAP M3 X 4.0 | 241 |
| - | - | 2 | - | - | 2168400-6 | SHCS, LOW HEAD, RoHS, M5 X 16 | 240 |
| - | - | - | - | 1 | 2119580-1 | MECHANICAL FEED ASSEMBLY | 239 |
| - | - | - | 1 | - | 2063440-1 | AIR FEED MODULE | 238 |
| - | - | 1 | - | - | 2119740-2 | TAG, IDENTIFICATION | 213 |
| - | - | 1 | - | - | 1901094-3 | SPACER, FEEDER | 198 |
| - | - | - | 2 | - | 21045-3 | RING, RETAIN, EXTERN, 3/16 CRESCENT | 172 |
| - | 1 | 1 | 1 | 1 | 994969-1 | MAGNET, RARE EARTH HIGH ENERGY | 166 |
| - | REF | REF | REF | REF | 994970-2 | COUNTER, MAGNETIC | 164 |
| - | - | - | 1 | - | 240638-1 | SPRING, FEED FINGER | 163 |
| - | 1 | 1 | 1 | 1 | 8-21084-1 | O-RING, .801 ID, .070 DIA. MAT. | 152 |
| - | - | - | 1 | - | 2119641-2 | FEED CAM, AIR FEED | 151 |
| - | 1 | 1 | 1 | 1 | 2119798-2 | DETENT PIN | 145 |
| - | 1 | 1 | 1 | 1 | 2079383-8 | SCR, BHSC, RoHS (M4 X 16) | 144 |
| - | 4 | 4 | 4 | 4 | 2168400-5 | SHCS, LOW HEAD, RoHS, M4 X 20 | 143 |
| - | - | - | - | 1 | 2119653-2 | FEED CAM, POST FEED | 142 |
| - | 1 | 1 | 1 | 1 | 1-2119656-0 | APPLICATOR BASIC ASSEMBLY, SF | 141 |
| - | 1 | 1 | 1 | 1 | 2119650-1 | RAM, ASIAN STYLE, SIDE FEED | 140 |
| - | 1 | 1 | 1 | 1 | 2119092-2 | BOLT, ADJUSTMENT | 139 |
| - | - | - | 1 | - | 3-23627-7 | PIN, RETAIN, GRVD, 3/16 X .854 | 137 |
| - | - | - | 1 | - | 2119799-1 | HOLDER, FEED FINGER, AF | 136 |
| - | - | REF | - | - | SEE NOTE 4 | MEMORY CHIP, PROGRAMMED | 135 |
| - | - | 1 | - | - | 1633743-1 | SERVO FEED LATCH ASM | 133 |
| - | 1 | 1 | 1 | 1 | 1-18028-2 | WASHER, FLAT, REG M4 | 119 |
| - | - | REF | - | - | 2119944-1 | FEED FINGER ASSEMBLY, SF | 117 |
| - | 1 | 1 | 1 | 1 | 1-455888-4 | SPACER, CRIMPER | 82 |
| - | 1 | 1 | 1 | 1 | 2119956-1 | DOCUMENTATION PACKAGE | 71 |
| - | 1 | - | 1 | 1 | 2119740-1 | TAG, IDENTIFICATION | 67 |
| - | 2 | 2 | 2 | 2 | 2168078-1 | SCREW, DRIVE, RH, RoHS, 2 x .188 | 66 |
| - | 1 | 1 | 1 | 1 | 2119793-1 | LIMITER, ADJUSTMENT BOLT | 63 |
| - | 3 | 3 | 3 | 3 | 992763-5 | SCR, SET, SOC, CONE POINT, M3 x 4.0 | 62 |
| - | - | - | 1 | 1 | 5-18022-5 | SCR, HEX HD CAP, M4 X 6.0 | 59 |
| - | - | - | 1 | 1 | 1338685-1 | PAWL, FEED | 56 |
| - | - | - | 1 | 2 | 18023-9 | SCR, SKT HD CAP M4 X 6.0 | 49 |
| - | - | - | - | 1 | 2119652-1 | FEED CAM, PRE FEED | 48 |
| - | 1 | 1 | 1 | 1 | 2079383-7 | SCR, BHSC, RoHS (M8 X 25) | 41 |
| - | 1 | 1 | 1 | 1 | 2119645-1 | DISC, NUMBERED FA WIRE ADJUSTMENT | 40 |
| - | 1 | 1 | 1 | 1 | 2119957-1 | APPLICATOR SHIM PACK | 39 |
| - | 1 | 1 | 1 | 1 | 2119644-1 | RAM WASHER, PRECISION | 38 |
| - | 1 | 1 | 1 | 1 | 2-1752356-3 | SUPPORT, TERMINAL | 34 |
| - | 2 | 2 | 2 | 2 | 2079383-5 | SCR, BHSC, RoHS (M4 X 20) | 33 |
| - | 1 | 1 | 1 | 1 | 2161328-1 | HEX HEAD, FLANGED, M5 x 8mm LONG | 32 |
| - | 1 | 1 | 1 | 1 | 1320908-2 | SPACER, STRIP GUIDE | 30 |
| - | 1 | 1 | 1 | 1 | 2119959-1 | ASSEMBLY, STRIP GUIDE | 29 |
| - | 1 | 1 | 1 | 1 | 455888-6 | SPACER, CRIMPER | 28 |
| - | 1 | 1 | 1 | 1 | 1320928-2 | STRIP GUIDE | 24 |
| - | 1 | 1 | 1 | 1 | 2168083-2 | SCR, SKT HD CAP, RoHS, M4 X 8.0 | 21 |
| - | 1 | 1 | 1 | 1 | 1-18028-2 | WASHER, FLAT, REG M4 | 20 |
| - | 1 | 1 | 1 | 1 | 2119533-1 | STRIPPER, SIDE FEED | 19 |
| - | 1 | 1 | 1 | 1 | 2119806-1 | INSERT, SHEAR | 13 |
| - | 1 | 1 | 1 | 1 | 3-22280-3 | SPRING, COMPRESSION | 12 |
| - | 1 | 1 | 1 | 1 | 1-356885-4 | STOP, SHEAR | 11 |
| - | 1 | 1 | 1 | 1 | 2119805-1 | SHEAR HOLDER, FRONT | 10 |
| - | 1 | 1 | 1 | 1 | 462006-6 | FLOATING SHEAR, FRONT | 9 |
| - | 1 | 1 | 1 | 1 | 1803079-7 | ANVIL, WITH STABILIZER | 8 |
| - | - | - | - | - | - | - | 7 |
| - | - | - | - | - | - | - | 6 |
| - | 1 | 1 | 1 | 1 | 2119757-8 | DEPRESSOR, SHEAR | 5 |
| - | 1 | 1 | 1 | 1 | 2-238011-0 | BLOCK, CRIMPER SPACER | 4 |
| - | 1 | 1 | 1 | 1 | 8-2119582-4 | CRIMPER, INSULATION F PREMIUM | 3 |
| - | 1 | 1 | 1 | 1 | 455888-3 | SPACER, CRIMPER | 2 |
| - | 1 | 1 | 1 | 1 | 1-456401-3 | CRIMPER, WIRE PREMIUM | 1 |

| DIMENSIONS: | | TOLERANCES UNLESS OTHERWISE SPECIFIED: | | DRAWING NO | |
|-------------|---------------|--|------------|--------------|------------|
| mm | 0 PLC ±.05 | 1 PLC ±.05 | 2 PLC ±.05 | 3 PLC ±.05 | 4 PLC ±.05 |
| | ANGLES ±.0001 | | | | |
| MATERIAL | | FINISH | | WEIGHT | |
| | | | | SCALE | |
| | | | | SHEET 3 OF 4 | |
| | | | | REV A | |

| LOC | | DIST | | REVISIONS | | | |
|-----|----|------|-----|-------------|------|-----|------|
| A | 66 | P | LTM | DESCRIPTION | DATE | DMN | APVD |
| | | - | | SEE SHEET 1 | | | |

FEED TYPE MECHANICAL



PNEUMATIC

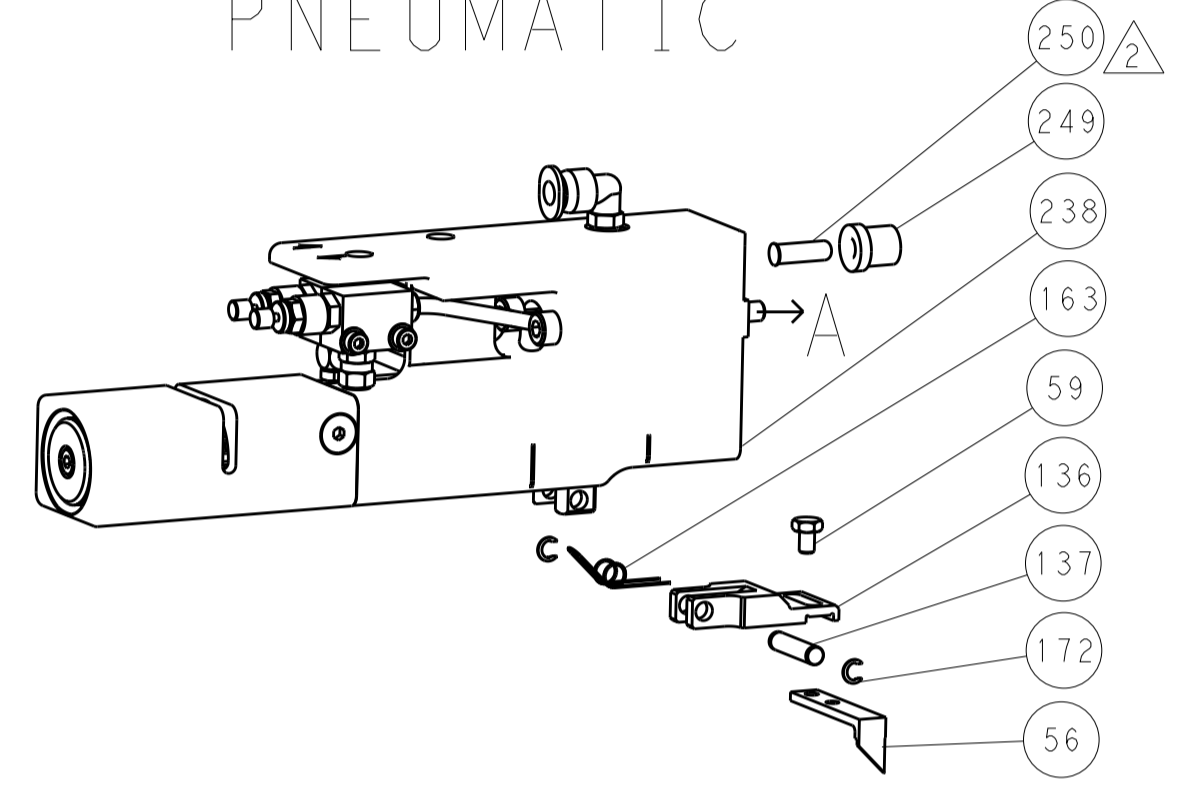

SERVO LATCH PLATE



CAM POSITIONS

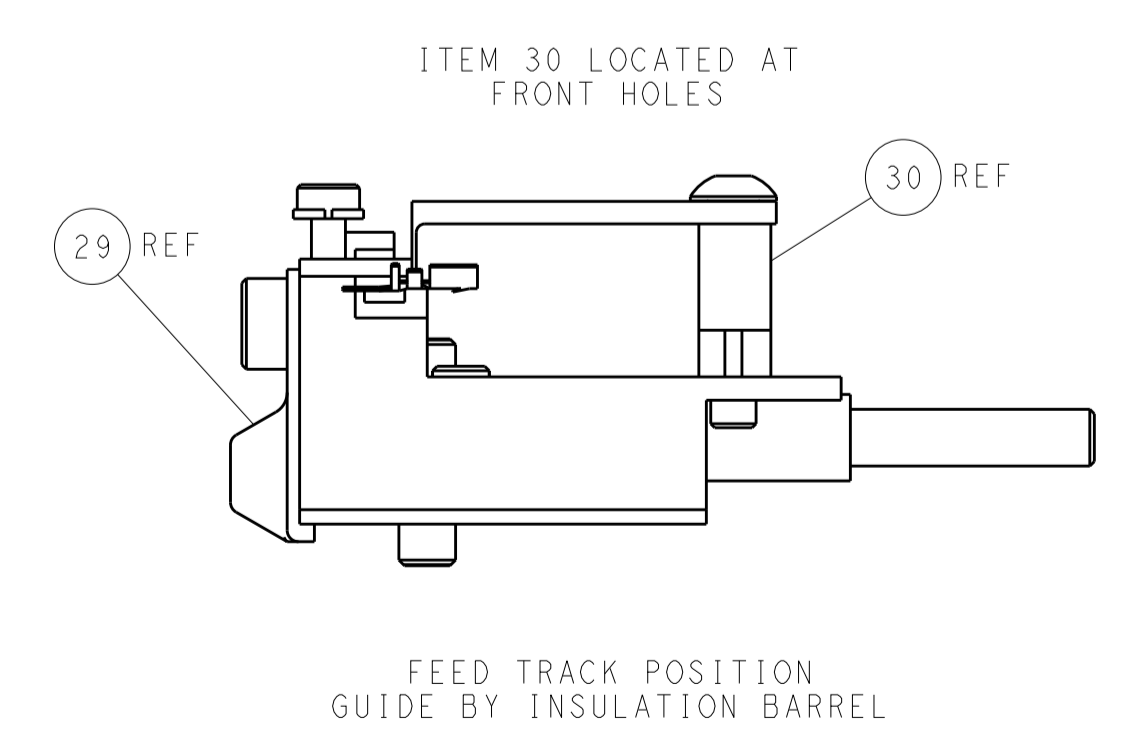
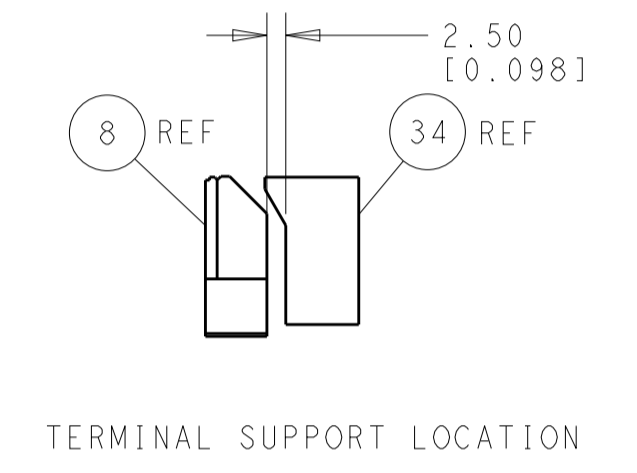
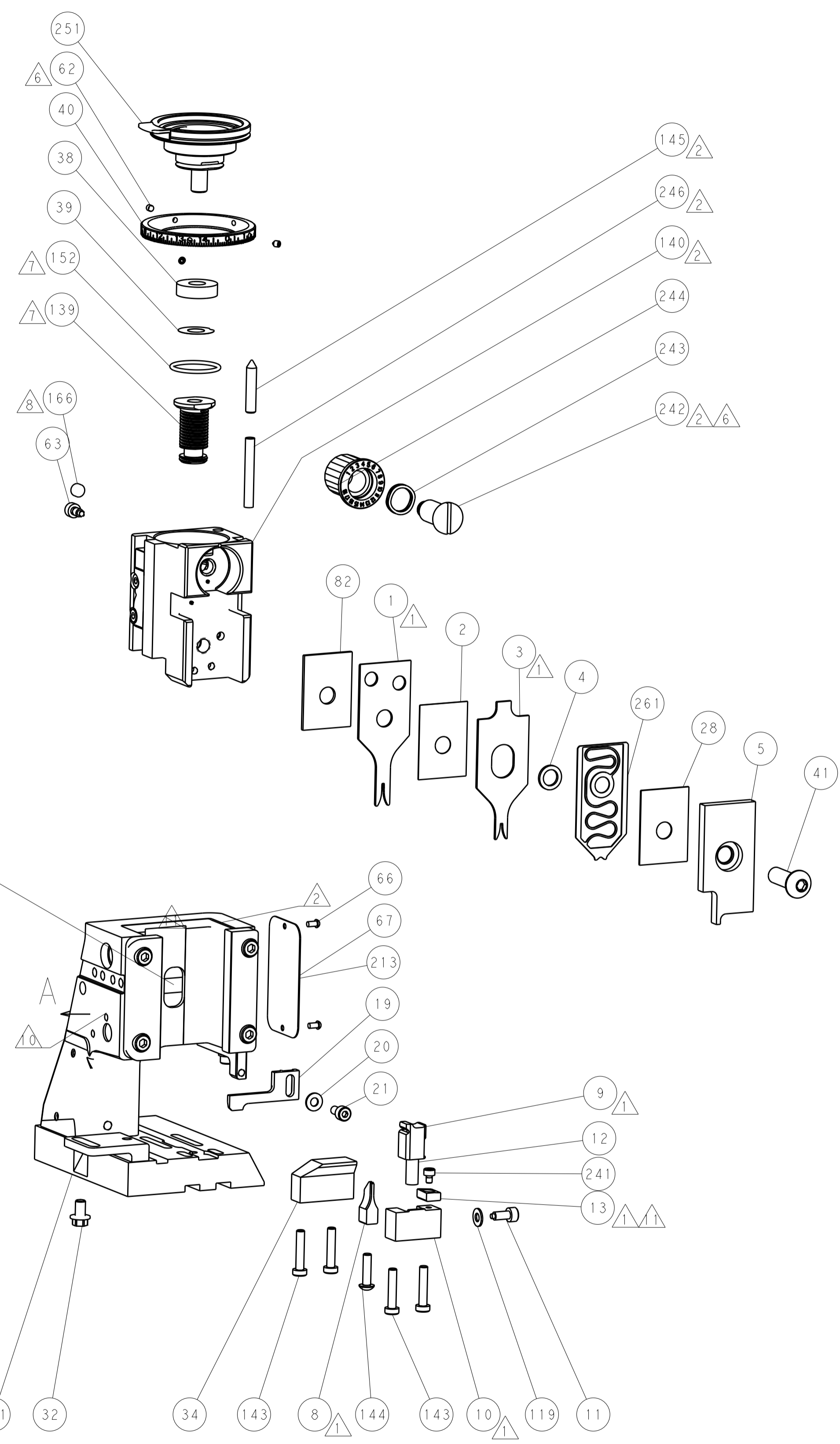

PACIFIC VERSION
 Shown on sheets 3 of 4 & 4 of 4
 (Atlantic version shown on sheets 1 of 4 & 2 of 4)

| | | | | | | | | | |
|-------------|------------|--|--------------|------------------------|---------------|-------------------------|---------------|----------------------------------|------------------|
| DIMENSIONS: | | TOLERANCES UNLESS OTHERWISE SPECIFIED: | | DWG: C. CHEN 24JUL2013 | | REV: U. GUO 24JUL2013 | | NAME: Ocean Side Feed Applicator | |
| mm | 0 PLC ±0.5 | 1 PLC ±0.13 | 2 PLC ±0.013 | 3 PLC ±0.001 | 4 PLC ±0.0001 | APVD: J. CRUZ 24JUL2013 | PRODUCT SPEC: | SIZE: A1 | CAGE CODE: 00779 |
| MATERIAL: | FINISH: | WEIGHT: | ANGLES: | SCALE: 1:2 | SHEET: 4 | OF: 4 | REV: A | RESTRICTED TO: | |