



a module solution provider

WS2116EA0 User Guide

WS2116-A0 Development Kit

Draft 0.1

Prepared By	Reviewed By	Approved By

Index

1. INTRODUCTION	2
2. GETTING STARTED	3
2.1. SYSTEM REQUIREMENTS.....	3
2.2. APPLICATION SOFTWARE SETUP	3
3. HARDWARE DESCRIPTION.....	4
3.1. BOARD OVERVIEW	4
3.2. WS2116-A0 MODULE CONNECTIONS.....	5
3.3. POWER SUPPLY	7
3.4. OTHER JUMPERS.....	8
3.5. EXTENSION CONNECTORS	8
3.6. PUSH BUTTONS	8
3.7. JTAG CONNECTOR	9
3.8. LEDs	9
3.9. STM32L151C8U6 MICROCONTROLLER	9
3.10. HARDWARE SETUP	9
4. SCHEMATIC DIAGRAMS.....	10
5. HISTORY CHANGE	14

1. INTRODUCTION

The Jorjin WS2116-A0 is a sub-1GHz with PA and Bluetooth® low energy ultralow power wireless MCU module. The WS2116EA0 is the development kit for WS2116-A0. The WS2116EA0 provides a set of hardware resources for RF signal evaluation of both BLE and Sub-1GHz and development platform. It also provides a set of hardware resources for a wide range of application scenarios: sensor data (accelerometer, pressure and temperature sensor, need an additional sensor board), remote control (buttons and LEDs) and debug message management through USB virtual COM. Three power options are application development and testing flexibility.

Figure 1: WS2116EA0 development kit

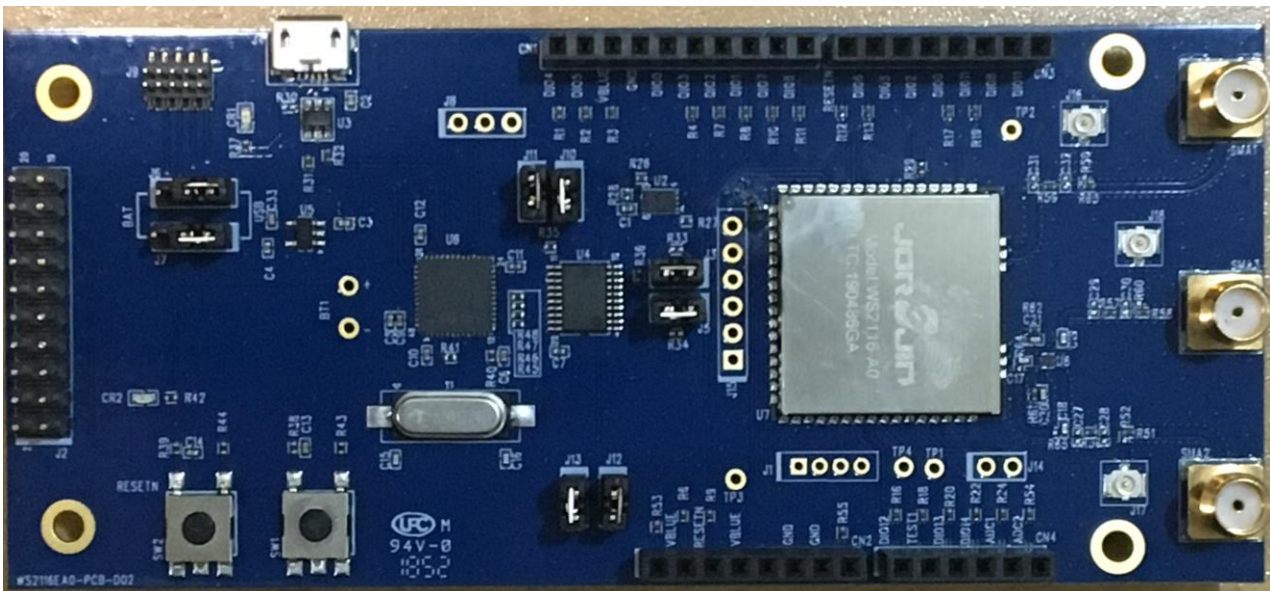

2. GETTING STARTED

2.1. System requirements

The application software requirement:

- PC with Intel® or AMD® processor running one of the following Microsoft® operating systems:
 - Windows XP SP3
 - Windows Vista
 - Windows 7
 - Windows 10
- At least 128 MB of RAM
- USB ports
- At least 40MB of available hard disk space
- Adobe Acrobat Reader 6.0 or later

2.2. Application software setup

Please download the application from below link.

BlueNRG-2 DK SW package:

https://www.st.com/content/st_com/en/products/embedded-software/evaluation-tool-software/stsw-bluenrg1-dk.html

BLUENRG family GUI:

[STSW-BNRGUI - BLUENRG family GUI - STMicroelectronics](#)

And please contact Jorjin to get more application and development software.

3. HARDWARE DESCRIPTION

3.1. Board overview

The following figure and table describe physical sections of the board.

Figure 2: WS2116EA0 board components

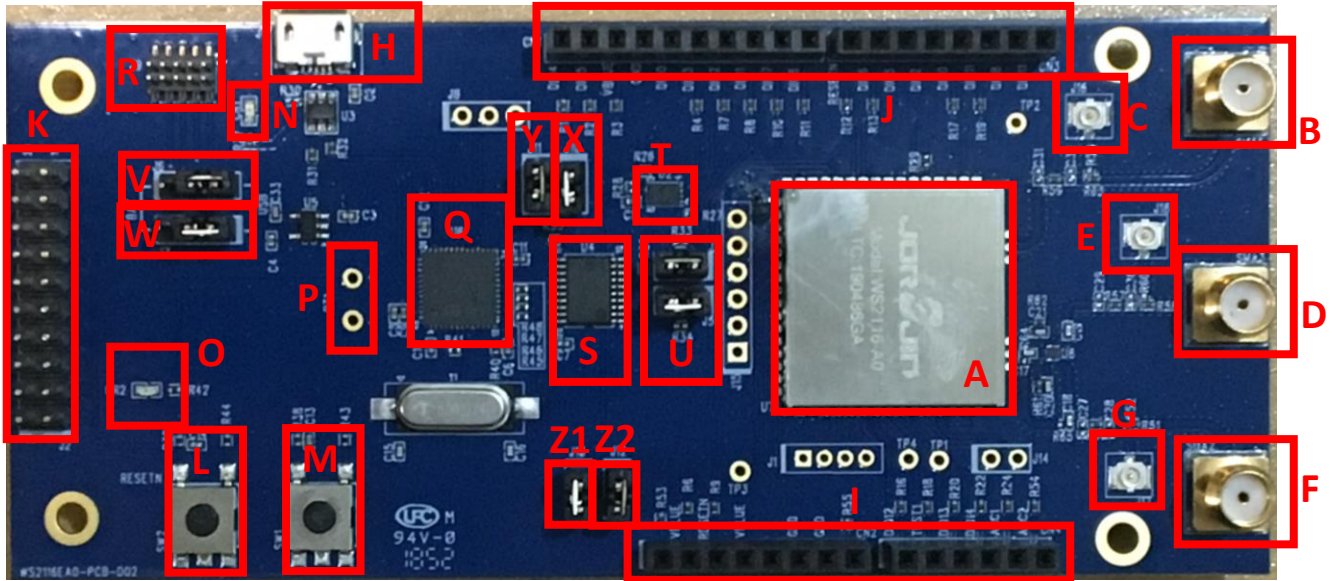

Table 1: WS2116EA0 board component descriptions

Region	Description
A	WS2116-A0 Module
B, C	BLE RF signal SMA & U.FL connector, use SMA as RF path
D, E	Sub-1GHz RF signal SMA & U.FL connector, use SMA as RF path
F, G	Sub-1GHz RF signal SMA & U.FL connector, use SMA as RF path
H	Micro USB connector for power supply and I/O
I, J	Two rows of Arduino-compliant connectors
K	JTAG connector for BlueNRG-2
L	RESET button
M	USER button
N	PWR LED
O	User LED
P	Battery power input point

Q	STM21L151CUBU6 48-pin microcontroller(USB to serial bridge for I/O channel to PC communication) ⁽¹⁾
R	JTAG connector for STM32L151CUBU6 ⁽¹⁾
S	ST2378E level translator to adapt voltage level between STM32 and BlueNRG-2
T	EEPROM
U	Serial port connection jumpers
V, W	Power source selection jumpers
X	DIO6 function selection jumper
Y	Current measurement jumper for BlueNRG-2
Z1	Current measurement jumper for S2LP
Z2	Current measurement jumper for SKY66420-11

(1) STM32 is not intended to be programmed by users

3.2. WS2116-A0 module connections

The WS2116-A0 for BLE and sub-1GHz module has one SMA connector for BLE. Two for sub-1GHz, and can choose antenna path as the RF out by setting switch parameter.

The microcontroller of BlueNRG-2 is connected to various components such as buttons, and LEDs. The following table describes the microcontroller pin functions.

Table 2: WS2116-A0 module pin description with board functions

Pin Name	Pin No	Function	Arduino Connectors			
			CN1	CN2	CN3	CN4
GND	1	GND	Pin7	Pin6,7		
RESETN	2	System reset		Pin3	Pin8	
DIO13	3					Pin3
DIO12	4		Pin1			
TEST	5	Test pin put to GND	TP2			
DIO11	6	UART Rx from STM32			Pin3	
DIO10	7	JTMS-SWTDIO				
DIO9	8	JTCK-SWTCK				
DIO25	9	SDN pin of S2-LP				
DIO7	10	Bootloader pin / LED driver	Pin2			

DIO8	11	UART Tx from STM32	Pin1			
DIO22	12	CTX pin of SKY66420-11				
DIO23	13	CPS pin of SKY66420-11				
GND	14	GND	Pin7	Pin6,7		
VBAT	15	Power for BlueNRG-2				
GND	16	GND	Pin7	Pin6,7		
DIO24	17	CSD pin of SKY66420-11				
DIO21	18	GPIO3 pin of S2-LP				
DIO6	19	RESET pin of STSAFE-A1SX or EEPROM_CS			Pin7	
DIO4	20	SCL pin of STSAFE-A1SX	Pin10			
DIO5	21	SDA pin of STSAFE-A1SX	Pin9			
DIO20	22	CS pin of S2-LP				
DIO19	23	GPIO2 of S2-LP				Pin5
DIO18	24	SPDT for 868MHz/915MHz selection				Pin2
DIO16	25					Pin6
DIO0	26	SCLK pin of S2-LP			Pin4	
DIO17	27	SPDT for 868MHz/915MHz selection		Pin8		
DIO1	28		Pin3			
DIO2	29	SDI pin of S2-LP	Pin4			
DIO3	30	SDO pin of S2-LP	Pin5			
GND	31	GND	Pin7	Pin6,7		
GPIO3	32					
GND	33	GND	Pin7	Pin6,7		
VCC_S2LP	34	Power for S2_LP				
GND	35	GND	Pin7	Pin6,7		
GPIO2	36					
GPIO1	37					
GPIO0	38					
DIO15	39			Pin1		
DIO14	40					Pin4
ANATEST1	41					
ANATEST0	42					
GND	43	GND	Pin7	Pin6,7		
ADC1	44					
ADC2	45					

VCC_PA1	46	Power Of SKY66420-11				
VCC_PA2	47	Power Of SKY66420-11				
GND	48	GND	Pin7	Pin6,7		

3.3. Power supply

Green LED CR1 (Figure 2: WS2116EA0 board components"-region N) signals the board is being powered, either via:

- micro USB connector J4 (Figure 2: WS2116EA0 board components" – region H)
- batteries (region P)
- an external DC power supply plus micro USB connector

The following table describes the power supply modes available on the WS2116EA0 board and corresponding jumper settings.

Table 3: WS2116EA0 kit platform power supply modes

Power supply mode	J7	J6	Comment
1- USB	Fitted: 1_2	Fitted: 2_3	USB supply through connector J4 (region H)
2- Battery	Fitted: 2_3	Fitted: 1_2	The supply voltage must be provided through battery pins (region P)
3- Combo	Fitted: 1_2	Optional	USB supply through connector J4 for STM32L1; J6 pin 2 external power for WS2116-A0 module

The normal power supply voltage range for WS2116-A0 is under below, more or less will damaged or not work, make sure to supply suitable voltage level.

Normal voltage: 3.3V

Min voltage: 2.2V

Max voltage: 3.6V

3.4. Other jumpers

The following jumpers are available:

Table 4: WS2116EA0 kit platform power supply modes

Region	Description
J1	Test points for S2-LP GPIO0-GPIO3
J3	UART TX of BlueNRG-2 is connected (Fitted) or disconnected (Not fitted) to STM32.
J5	UART RX of BlueNRG-2 is connected (Fitted) or disconnected (Not fitted) to STM32.
J8	pin 1 and 2 UART RX and TX of MCU pin 3 GND
J10	DIO6 of BlueNRG-2 could be connected (Fitted) or disconnected (Not fitted) to EEPROM_CS pin.
J11	Fitted: to provide VBLUE to BlueNRG-2. It can be used also for current measurement.
J12	Fitted: to provide VBLUE to SKY66420-11. It can be used also for current measurement.
J13	Fitted: to provide VBLUE to S2-LP. It can be used also for current measurement.

3.5. Extension connectors

WS2116-A0 module signal test points are shared on two Arduino-compliant connector rows: CN1, CN3 (Figure 2: "WS2116EA0 board components" – region J) and CN2, CN4 (region I). See Table 2: "WS2116-A0 module pin description with board functions".

You can also install some sensor module board in the WS2116EA0 kit platform through these extension connectors. Please contact Jorjin to get more information.

3.6. Push buttons

The board has one user button to reset the microcontroller (Figure 2: "WS2116EA0 board components" – region L) and one further button for application purposes (region M).

3.7. JTAG connector

A JTAG connector (Figure 2: "WS2116EA0 board components" – region K) allows BlueNRG-2 microcontroller programming and debugging with an in-circuit debugger and programmer such as ST-LINK/V2.

Only SWD mode is supported.

3.8. LEDs

LEDs CR1 (green, power LED) and CR2 (red) are available on the board (Figure 2: "WS2116EA0 board components" – regions N and O).

3.9. STM32L151CUB6 microcontroller

The most important feature of the STM32L151CUB6 48-pin microcontroller (Figure 2:"WS2116EA0 board components" –regions Q) is the USB to serial bridge providing an I/O channel with the BlueNRG-2 device.

The microcontroller is connected to the BlueNRG-2 device through an ST2378E level translator (region S).

The STM32L microcontroller on the board is not intended to be programmed by users. ST provides a pre-programmed firmware image for the sole purpose of interfacing BlueNRG-2 to a USB host device (e.g., a PC).The JTAG connector (Figure 2: "WS2116EA0 board components" –regions R) is only for Jorjin internal used.

3.10. Hardware setup

1. Connect one 2.4GHz antenna to BLE SMA connector (Figure2: "WS2116EA0 board components" – regions B) and connect one 868~915MHz antenna to Sub-1GHz SMA connector (regions F or D). The RF path of Sigfox could be selected by setting switch parameter. Default Sigfox RF path is region F connector.
2. Configure the board to USB power supply mode as per the jumper settings in Table 3: "WS2116EA0 kit platform power supply modes"
3. Connect the board to a PC via USB cable (connector J4)
4. Verify the power indication LED CR1 is on.

4. SCHEMATIC DIAGRAMS

Figure 3: WS2116EA0 Arduino-compliant connector

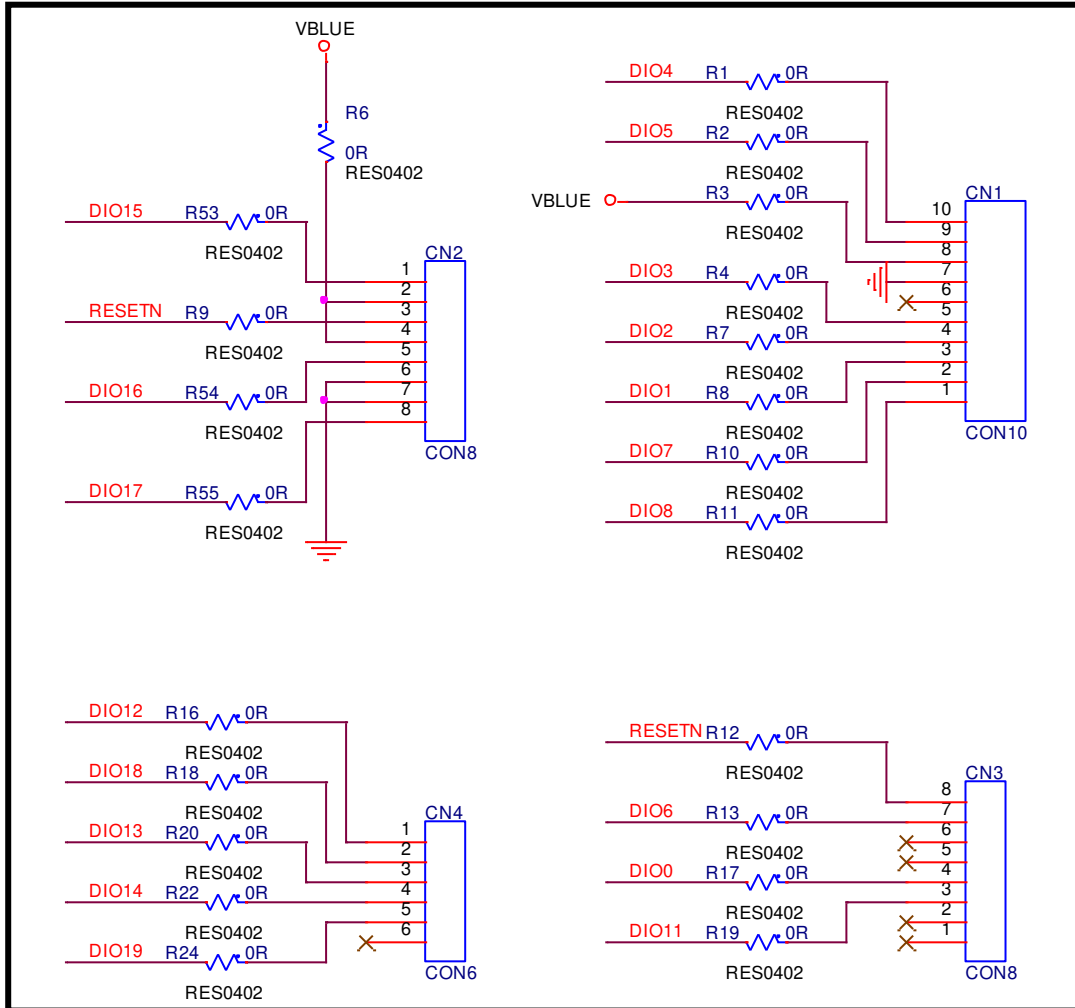

Figure 4: WS2116EA0 JTAG

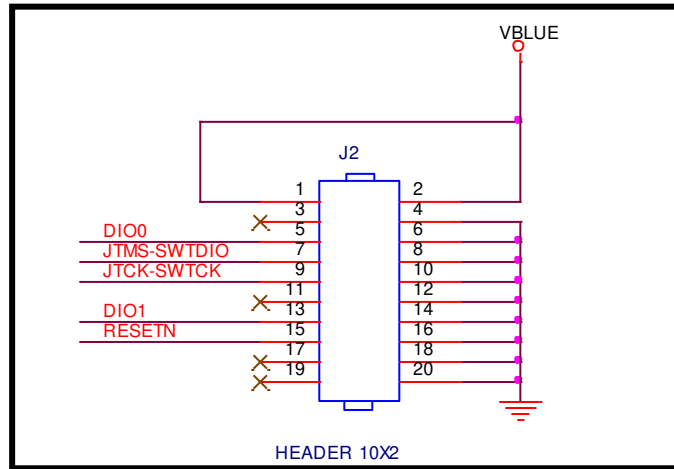

Figure 5: WS2116EA0 WS2116-A0 module

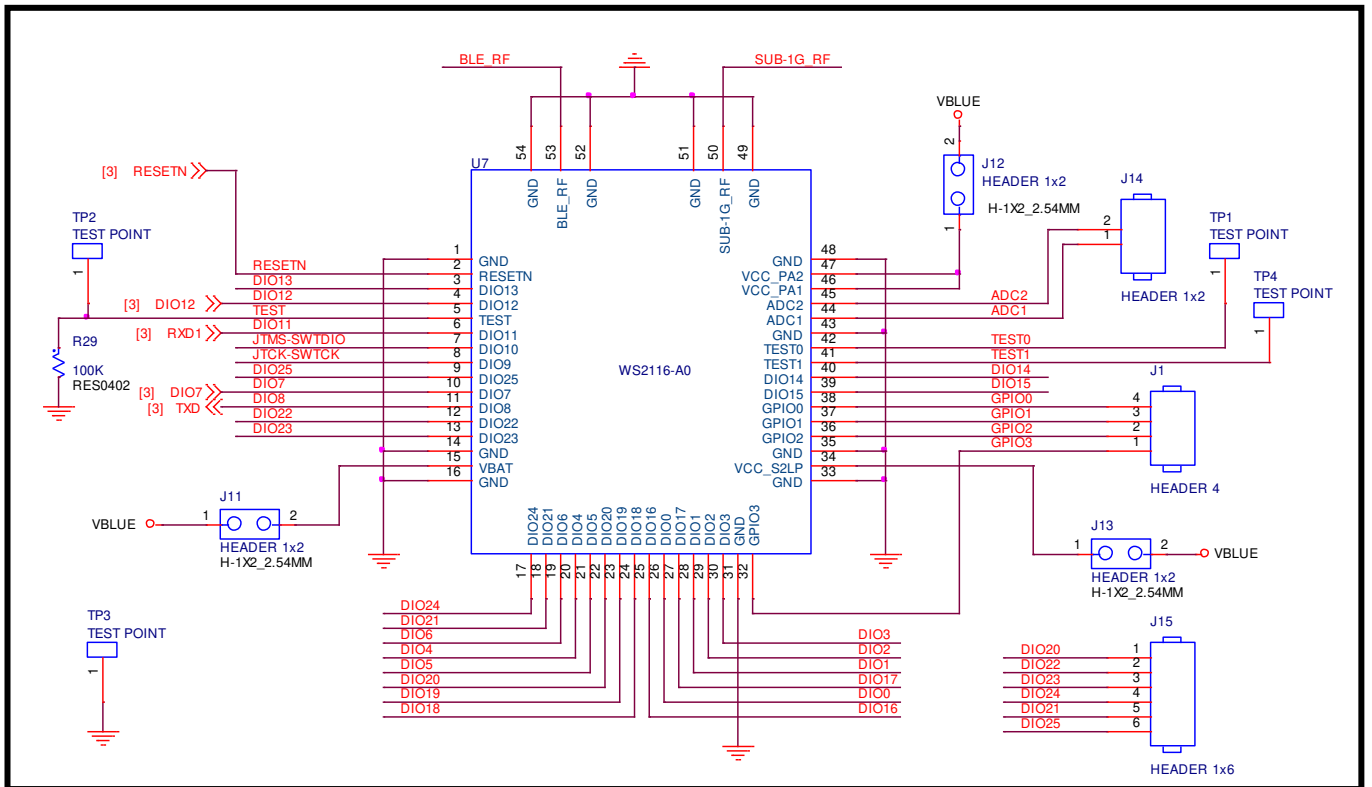

Figure 6: WS2116EA0 power

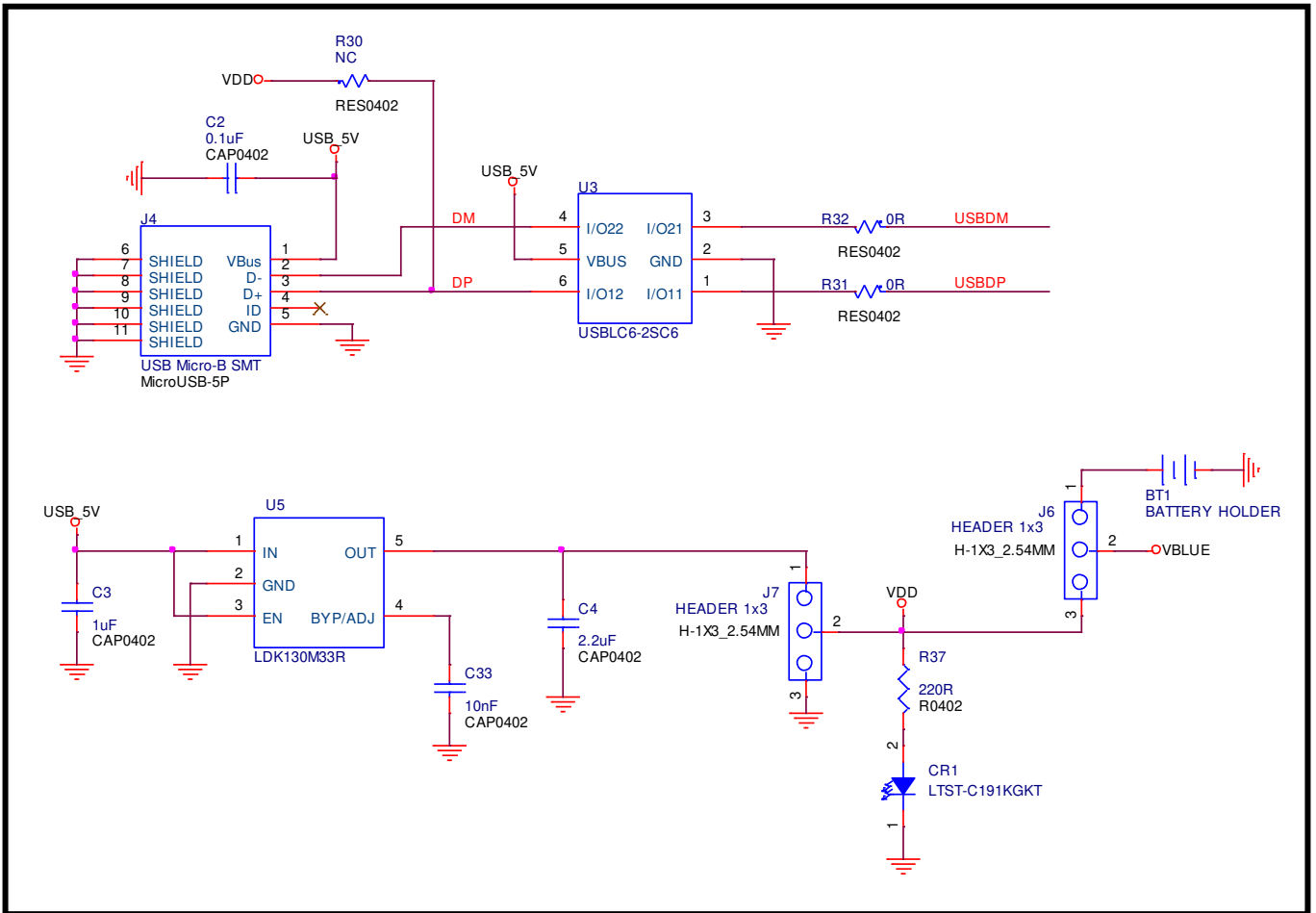

Figure 7: WS2116EA0 Level translator

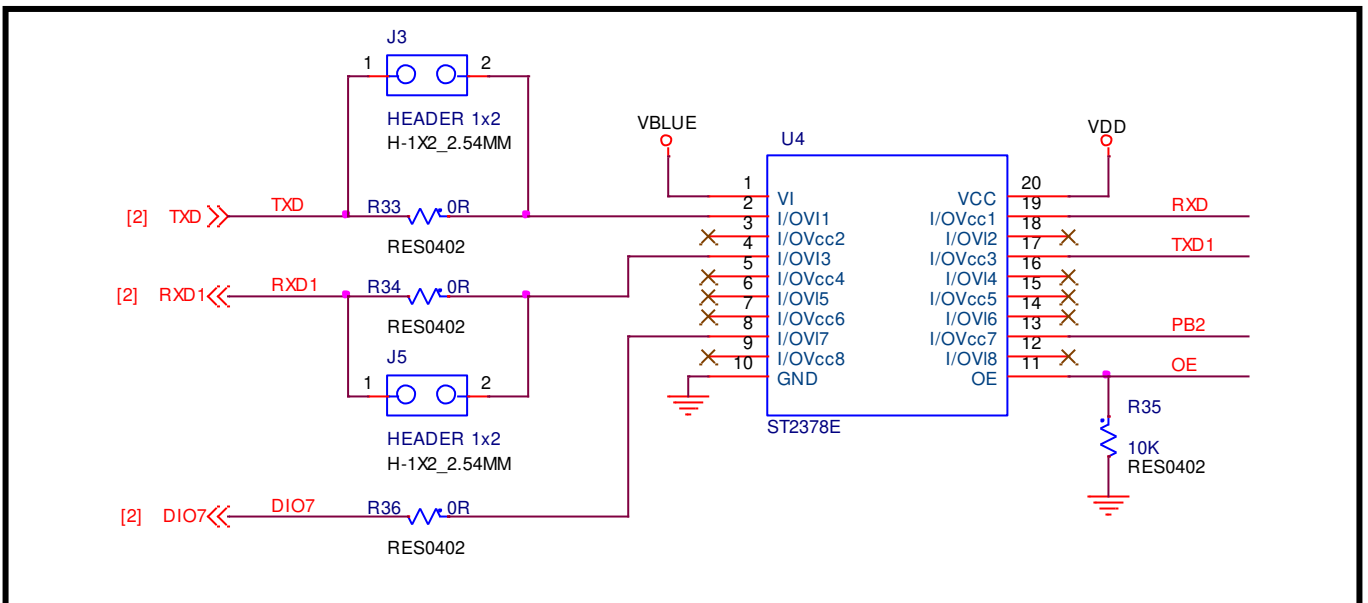

Figure 8: WS2116EA0 Micro controller

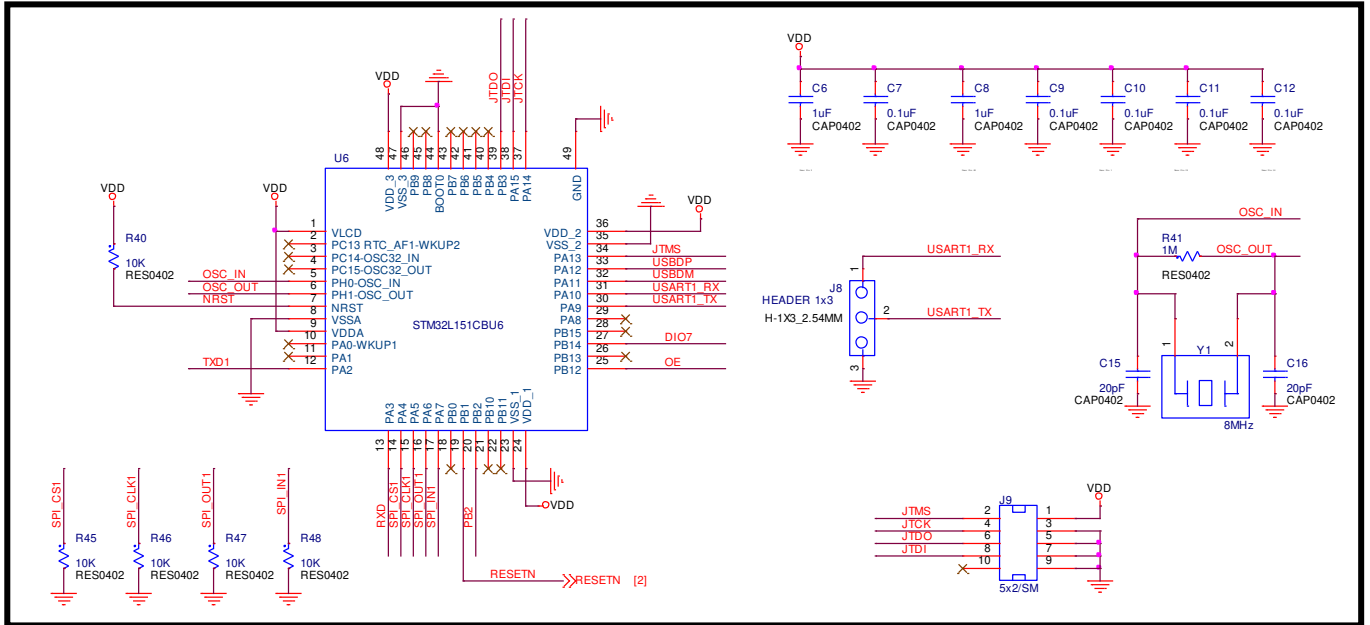
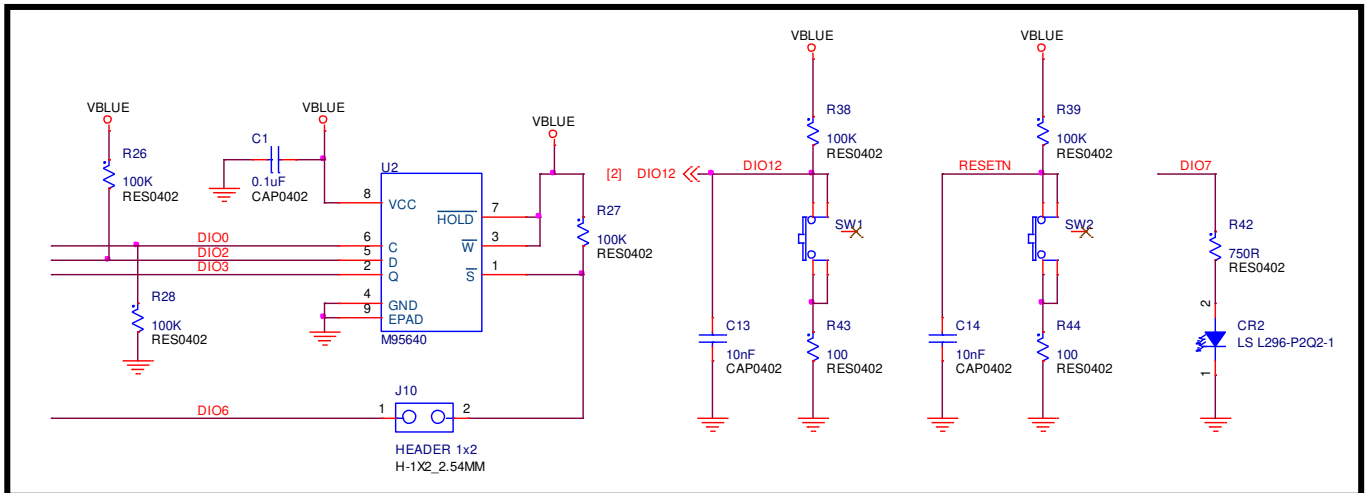

Figure 9: WS2116EA0 Micro controller



5. HISTORY CHANGE

Revision	Date	Description
D 0.1	2019/02/22	Initial release