

TABLE 1: WITH CONDUCTIVE LOSSY OPTION						
PART NUMBER	DESCRIPTION	A	B	C	N	
IC13411-011	PLUG ASSEMBLY, 12 POSITION, REGULAR, LOSSY	16.21	19.21	7.20	12	
IC13411-013	PLUG ASSEMBLY, 12 POSITION, SHORT, LOSSY	13.61	15.66	7.20	12	
IC13411-021	PLUG ASSEMBLY, 20 POSITION, REGULAR, LOSSY	23.41	26.41	14.40	20	
IC13411-023	PLUG ASSEMBLY, 20 POSITION, SHORT, LOSSY	20.81	22.86	14.40	20	
IC13411-041	PLUG ASSEMBLY, 40 POSITION, REGULAR, LOSSY	41.41	44.41	32.40	40	
IC13411-043	PLUG ASSEMBLY, 40 POSITION, SHORT, LOSSY	38.81	40.87	32.40	40	
IC13411-061	PLUG ASSEMBLY, 60 POSITION, REGULAR, LOSSY	59.41	62.41	50.40	60	
IC13411-063	PLUG ASSEMBLY, 60 POSITION, SHORT, LOSSY	56.81	58.87	50.40	60	
IC13411-081	PLUG ASSEMBLY, 80 POSITION, REGULAR, LOSSY	77.41	80.41	68.40	80	
IC13411-083	PLUG ASSEMBLY, 80 POSITION, SHORT, LOSSY	74.81	76.86	68.40	80	

TABLE 2: WITH NON-CONDUCTIVE LOSSY OPTION						
PART NUMBER	DESCRIPTION	A	B	C	N	
IC13411-012	PLUG ASSEMBLY, 12 POSITION, REGULAR, NON-COND. LOSSY	16.21	19.21	7.20	12	
IC13411-014	PLUG ASSEMBLY, 12 POSITION, SHORT, NON-COND. LOSSY	13.61	15.66	7.20	12	
IC13411-022	PLUG ASSEMBLY, 20 POSITION, REGULAR, NON-COND. LOSSY	23.41	26.41	14.40	20	
IC13411-024	PLUG ASSEMBLY, 20 POSITION, SHORT, NON-COND. LOSSY	20.81	22.86	14.40	20	
IC13411-042	PLUG ASSEMBLY, 40 POSITION, REGULAR, NON-COND. LOSSY	41.41	44.41	32.40	40	
IC13411-044	PLUG ASSEMBLY, 40 POSITION, SHORT, NON-COND. LOSSY	38.81	40.87	32.40	40	
IC13411-062	PLUG ASSEMBLY, 60 POSITION, REGULAR, NON-COND. LOSSY	59.41	62.41	50.40	60	
IC13411-064	PLUG ASSEMBLY, 60 POSITION, SHORT, NON-COND. LOSSY	56.81	58.87	50.40	60	
IC13411-082	PLUG ASSEMBLY, 80 POSITION, REGULAR, NON-COND. LOSSY	77.41	80.41	68.40	80	
IC13411-084	PLUG ASSEMBLY, 80 POSITION, SHORT, NON-COND. LOSSY	74.81	76.86	68.40	80	

REVISION HISTORY						
ZONE	ECN#	REV	DESCRIPTION	DATE	CHANGED BY	APPROVED
SH2 SH3	EC-134.07	D	ADDED CLIP WIDTH DIM AND NOTE 7	02/04/2020	M.CHARETH	D.MCNAMARA
SH4 SH2.C7 SH3.C7		E	UPDATED SHORT PCB DIM B IN TABLE 4 ADDED DIMENSION FROM FRONT OF SHROUD TO TIP OF LEAD	07/30/2020	M.CHARETH	DM.CNAMARA

IC13411 - 0 X X

POSITION

- 1 = 12
- 2 = 20
- 4 = 40
- 6 = 60
- 8 = 80

ASSEMBLY TYPE

- 1 = REGULAR (WITH GUIDE PINS) & CONDUCTIVE LOSSY
- 2 = REGULAR (WITH GUIDE PINS) & NON-CONDUCTIVE LOSSY
- 3 = SHORT (WITHOUT GUIDE PINS) & CONDUCTIVE LOSSY
- 4 = SHORT (WITHOUT GUIDE PINS) & NON-CONDUCTIVE LOSSY

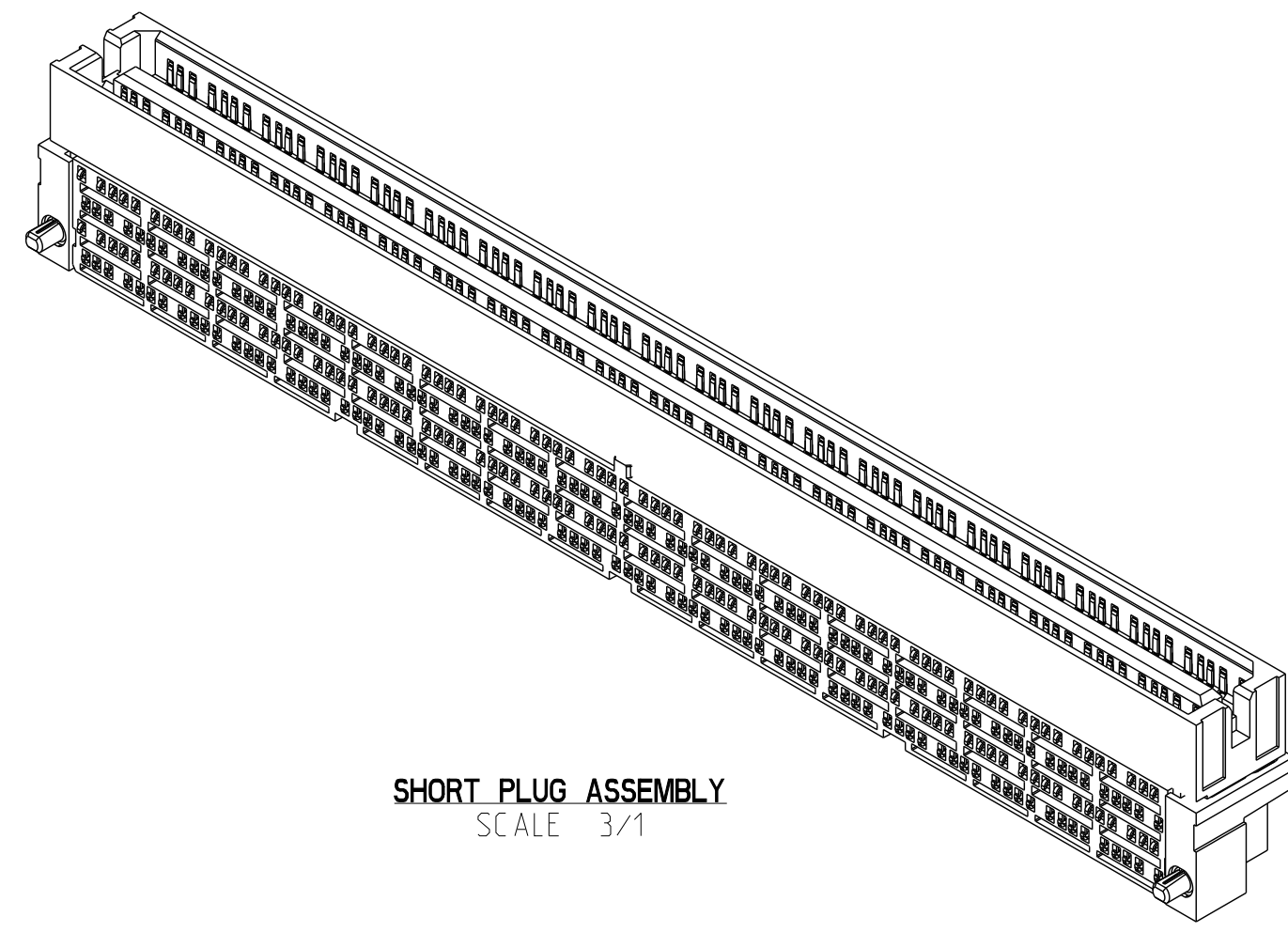
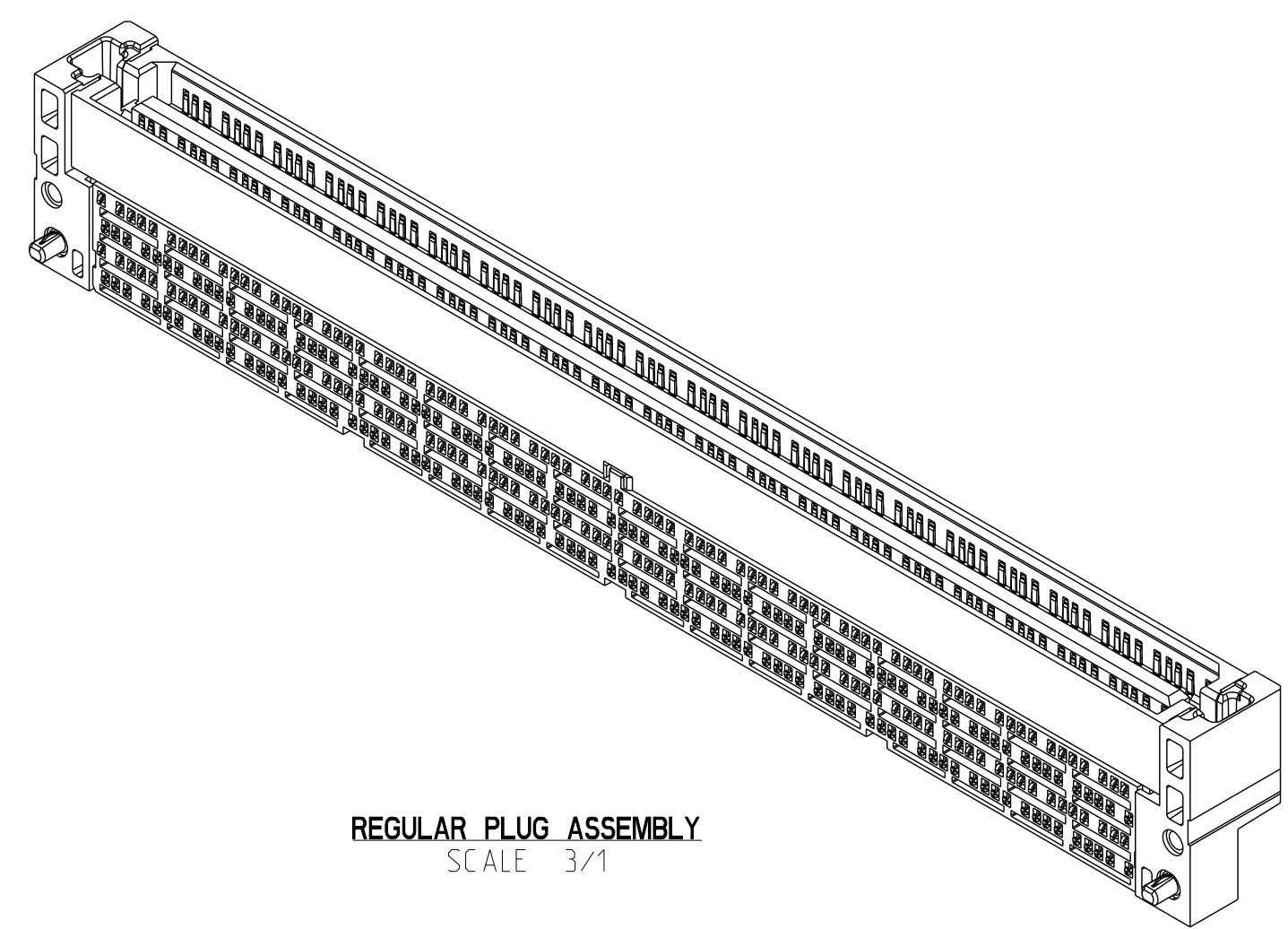

NOTES:

1. MATERIAL
HOUSING: HIGH TEMPERATURE LCP, COLOR: BLACK
CONTACT: COPPER ALLOY; THICKNESS: 0.12mm
CONTACT PLATING: UNDERPLATE WITH NICKEL, THICKNESS: 1.27 MICROMETER
HARD GOLD IN MATING AREA, THICKNESS: 0.76 MICROMETER
PURE MATTE TIN ON CONTACT TAIL, THICKNESS: 2.54 TO 7.62 MICROMETER
2. PLEASE REFER TO PRODUCT SPECIFICATION FOR MECHANICAL AND ELECTRICAL SPECIFICATION.
3. DATUM B IS DEFINED AS THE PLANE INTERSECTING THE Ø1.10MM POST AND PARALLEL TO DATUM A
4. DATUM C IS DEFINED AS THE PLANE INTERSECTING THE Ø1.10MM POST AND PERPENDICULAR TO DATUM B.
5. THIS DIMENSION IS MEASURED (FOR EACH SOLDER LEAD) AS THE DEVIATION FROM A BEST-FIT PLANE CREATED FROM THE SURFACES REFERENCED AT THE ENDS OF THE PART.
6. THIS DIMENSION IS MEASURED (FOR EACH SOLDER LEAD) AS THE DEVIATION FROM A BEST-FIT PLANE CREATED FROM ALL THE SOLDER LEADS.
7. THE RETENTION CLIP IS TO PROVIDE SUPPORT FOR THE CONNECTOR BEFORE AND DURING REFLOW

DO NOT SCALE DRAWING UNLESS OTHERWISE SPECIFIED
DIMENSIONS & TOLERANCES ARE MILLIMETERS
DIMENSIONING PER ASME Y14.5M-2009
TOLERANCES UNLESS SPECIFIED

0.0 = ± 0.15
0.00 = ± 0.05
0.000 = ± 0.025
ANGLES = ± 1°

INSPECTION DIMENSION (REFERENCE DIMENSION)

THIRD ANGLE PROJECTION

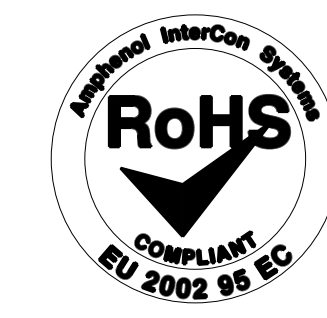

APPROVALS		DATE
DRAWN BY: HCL-SA		03/15/2019
CHK'D BY: M.CHARETH		03/15/2019
DESIGNED BY/PROJ. ENG: D.MCNAMARA		02/15/2019
PROCESS ENGINEERING: M.CHARETH		03/15/2019

THESE DRAWINGS AND SPECIFICATIONS ARE THE PROPERTY OF AMPHENOL CORPORATION AND SHALL NOT BE REPRODUCED, COPIED OR USED AS THE BASIS FOR THE MANUFACTURE OR SALE OF APPARATUS WITHOUT THE WRITTEN PERMISSION OF AMPHENOL CORPORATION.

Amphenol InterCon Systems

AMPHENOL INTERCON SYSTEMS INC.
825 OLD TRAIL RD, SUITE A
ETTERS, PA 17319
(717) 915-1400

TITLE:
**LYNX QD PLUG ASSEMBLY
RIGHT ANGLE**

SIZE: D DRAWING NO. **13411C** REV **E**

SCALE: 3/1 DWG TYPE: CUSTOMER USE SHEET: 1 OF 5

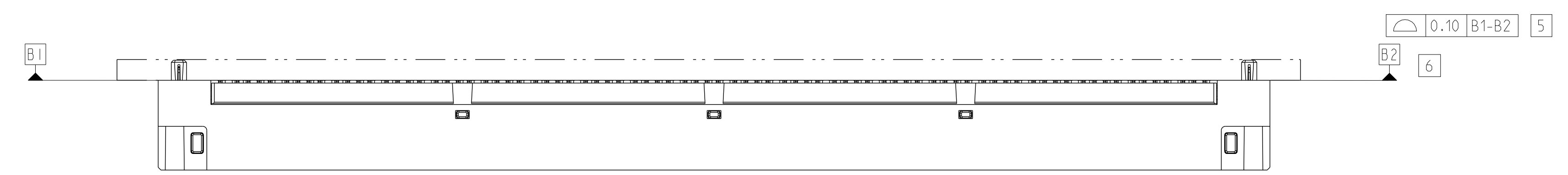
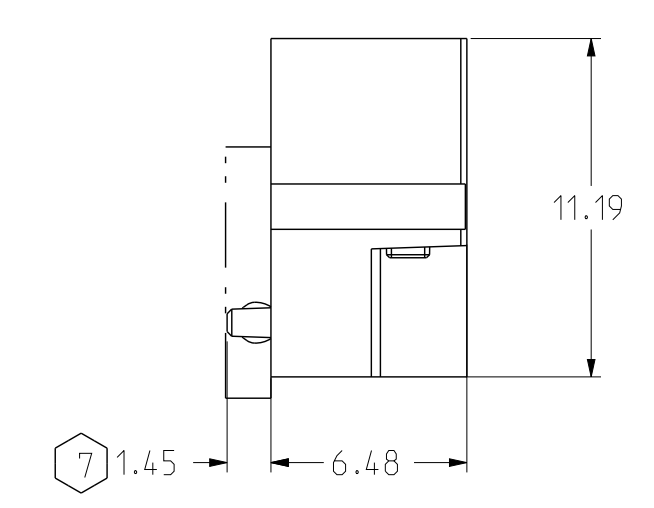
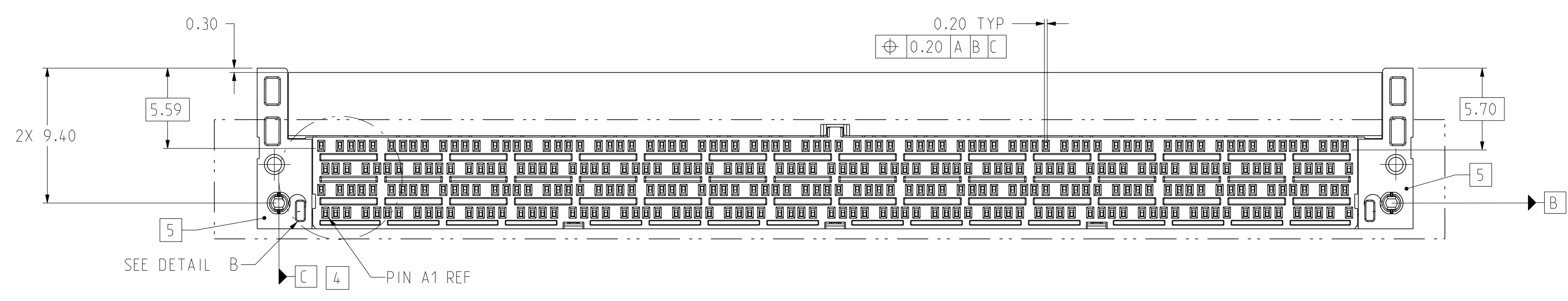
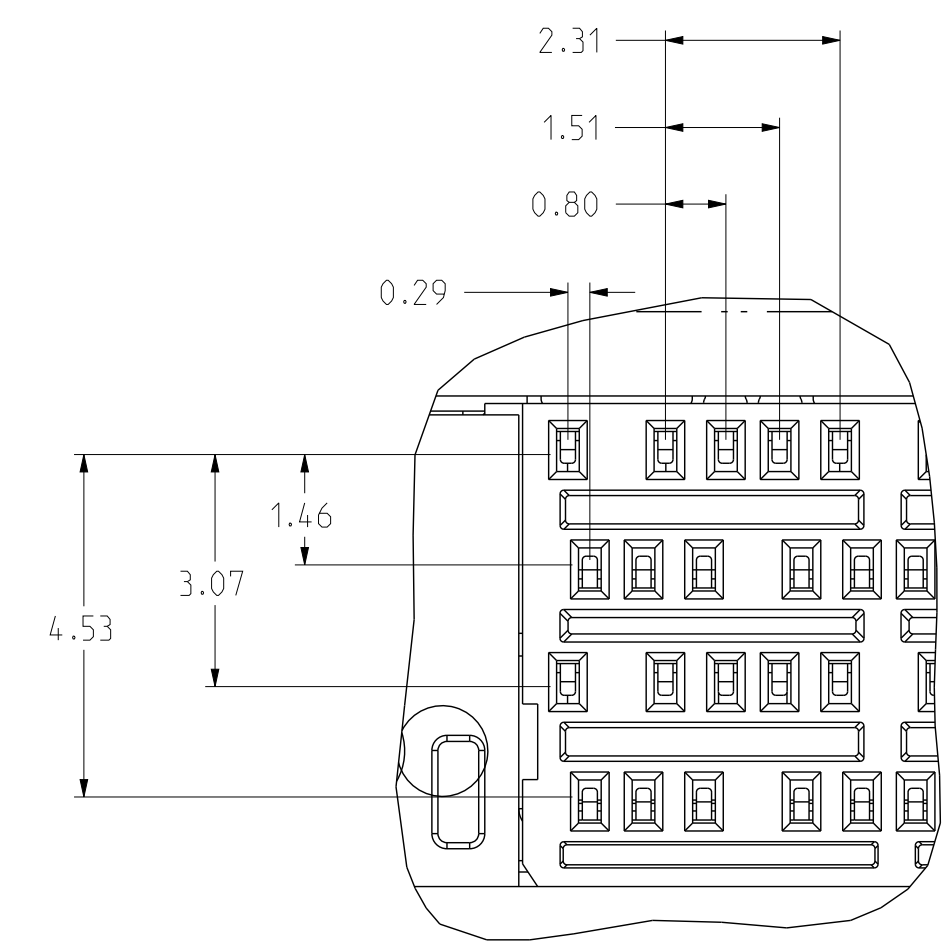
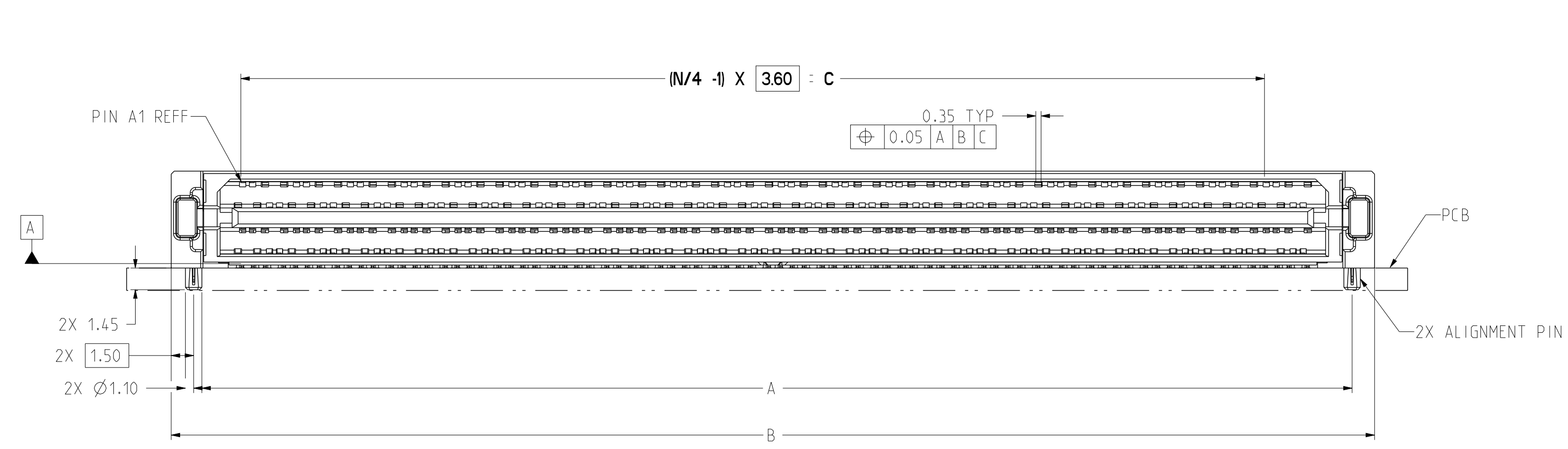

REGULAR PLUG ASSEMBLY

Amphenol
InterCon Systems
AMPHENOL INTERCON SYSTEMS INC.
825 OLD TRAIL RD, SUITE A
ETTERS, PA 17319
(717) 915-1400

SIZE	DRAWING NO.	REV
D	13411C	E
SCALE: 7/1	DWG TYPE: CUSTOMER USE	SHEET: 2 OF 5

8 7 6 5 4 3 2 1

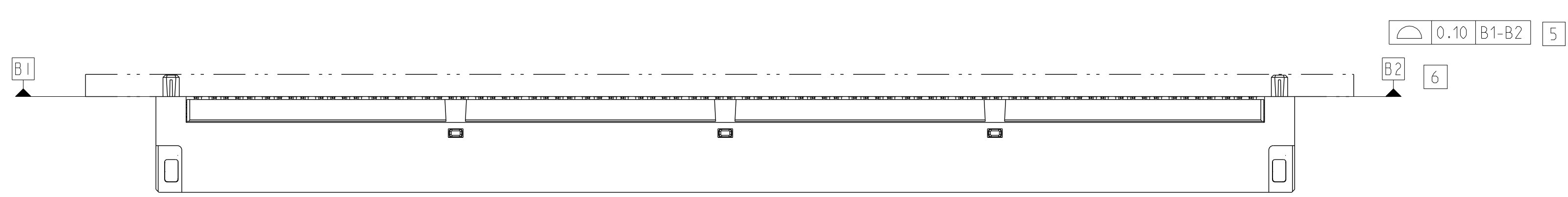
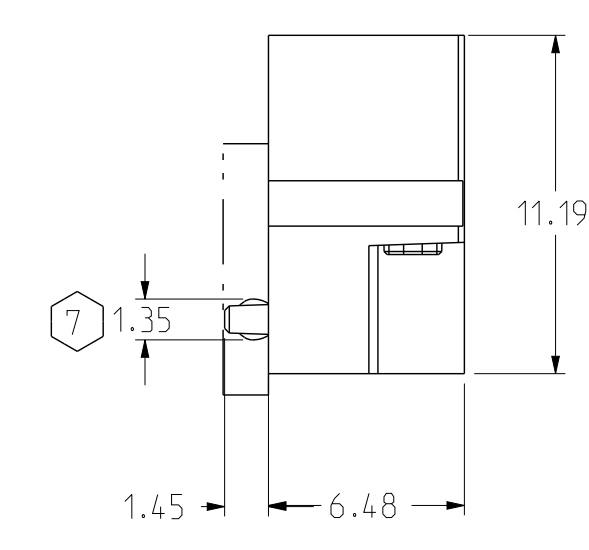
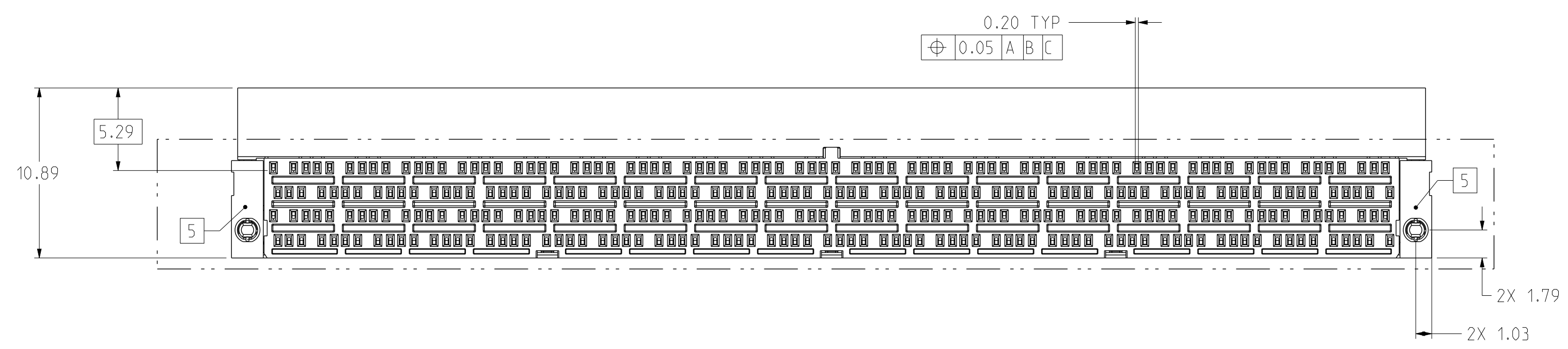
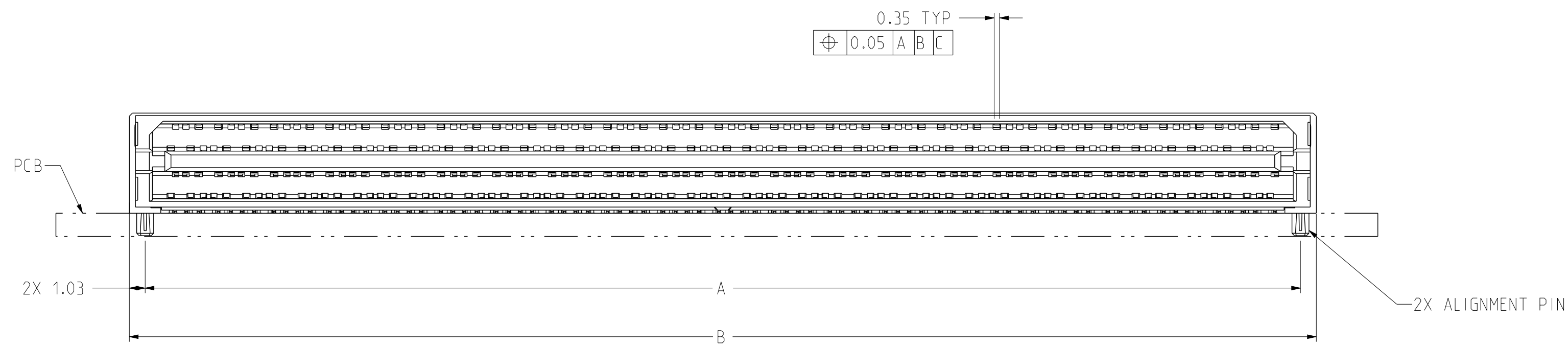

SHORT PLUG ASSEMBLY

NOTE:
 OTHER DIMENSION AND FEATURES WILL REMAIN SAME AS REGULAR PLUG ASSEMBLY.

THESE DRAWINGS AND SPECIFICATIONS ARE THE PROPERTY OF AMPHENOL CORPORATION (AMPHENOL INTERCON - A DIVISION OF AMPHENOL CORPORATION) AND SHALL NOT BE REPRODUCED, COPIED OR USED AS THE BASIS FOR THE MANUFACTURE OR SALE OF APPARATUS WITHOUT THE WRITTEN PERMISSION OF AMPHENOL CORPORATION.

Amphenol InterCon Systems		AMPHENOL INTERCON SYSTEMS INC. 825 OLD TRAIL RD, SUITE A ETTERS, PA 17319 (717) 915-1400	
SIZE	DRAWING NO.	REV	
D	13411C	E	
SCALE: 5/1	DWG TYPE: CUSTOMER USE	SHEET: 3 OF 5	

8 7 6 5 4 3 2 1

TABLE 3: REGULAR PCB				
PART NUMBER	N	A	B	C
IC 13411-01(1.2)	12	16.81	16.21	7.20
IC 13411-02(1.2)	20	24.01	23.41	14.40
IC 13411-04(1.2)	40	42.01	41.41	32.40
IC 13411-06(1.2)	60	60.01	59.41	50.40
IC 13411-08(1.2)	80	78.01	77.41	68.40

TABLE 4: SHORT PCB			
PART NUMBER	N	B	C
IC 13411-01(3.4)	12	13.61	7.20
IC 13411-02(3.4)	20	20.81	14.40
IC 13411-04(3.4)	40	36.81	32.40
IC 13411-06(3.4)	60	52.81	50.40
IC 13411-08(3.4)	80	74.81	68.40

LYNX QD PINOUT - PATTERN CONTINUES - 12pos SHOWN					
	A	B	C	D	
1	SIG		SIG		1
2	SIG	GND	SIG	GND	2
3		SIG		SIG	3
4	GND	SIG	GND	SIG	4
5	SIG		SIG		5
6	SIG	GND	SIG	GND	6
7		SIG		SIG	7
8	GND	SIG	GND	SIG	8
9	SIG		SIG		9
10	SIG	GND	SIG	GND	10
11		SIG		SIG	11
12	GND	SIG	GND	SIG	12
	A	B	C	D	

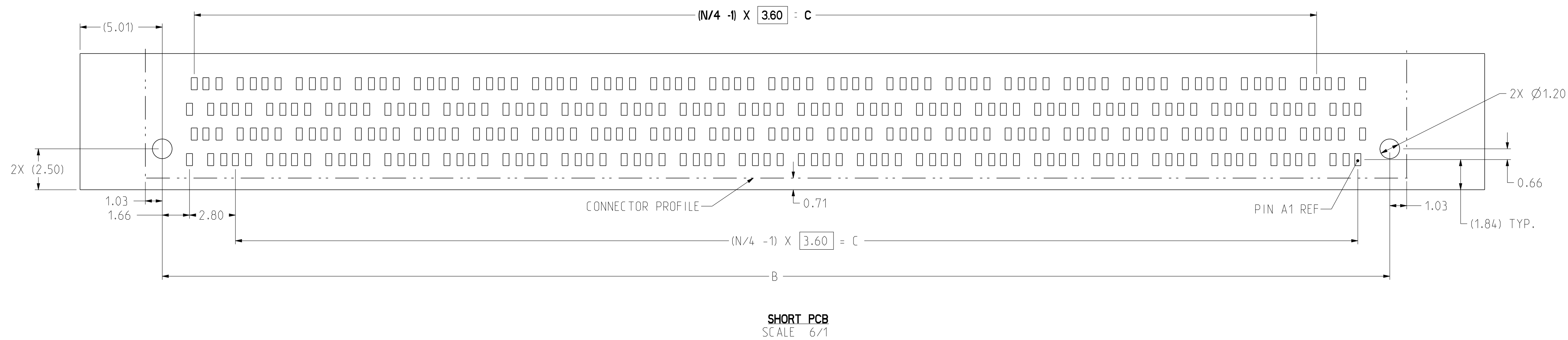
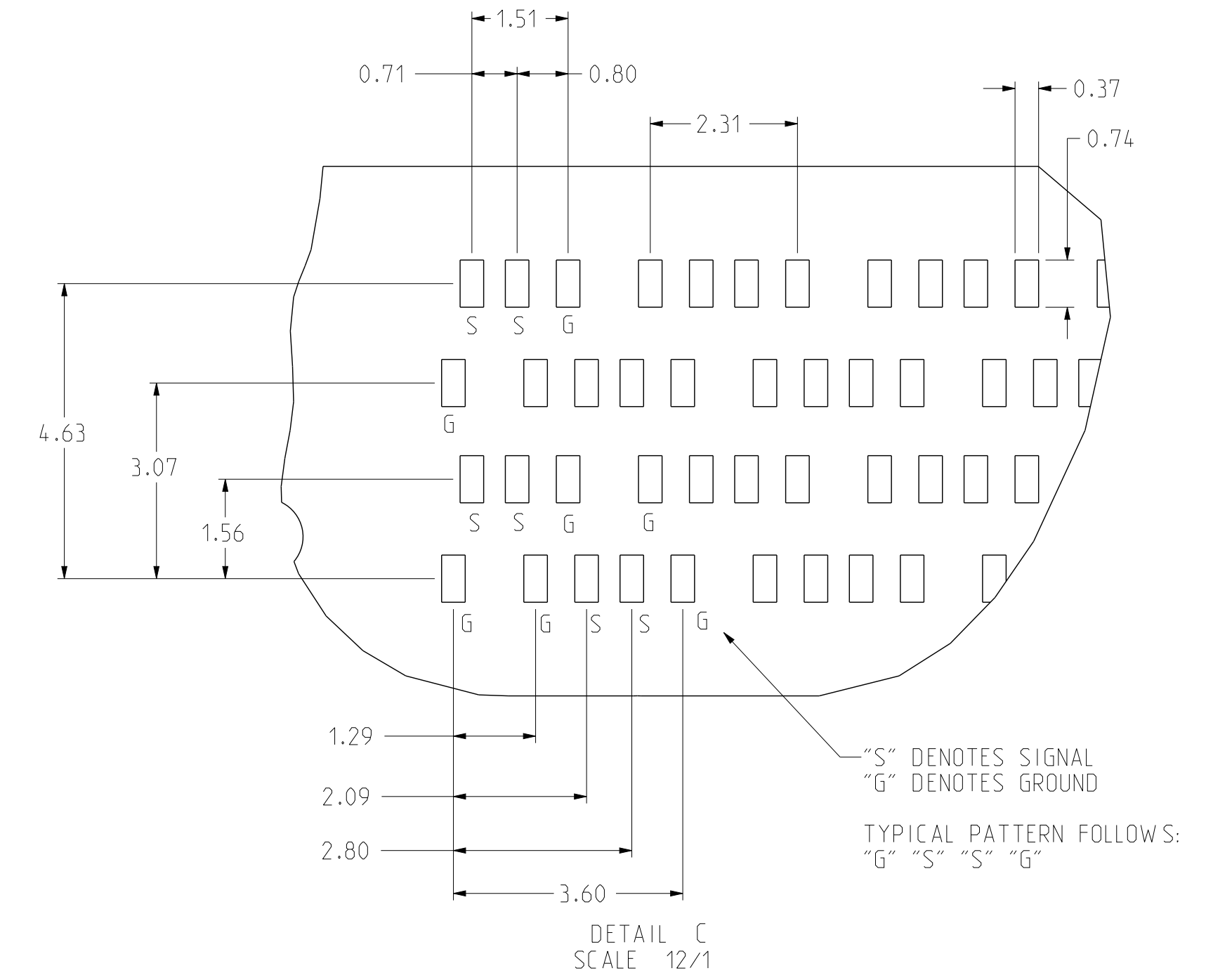
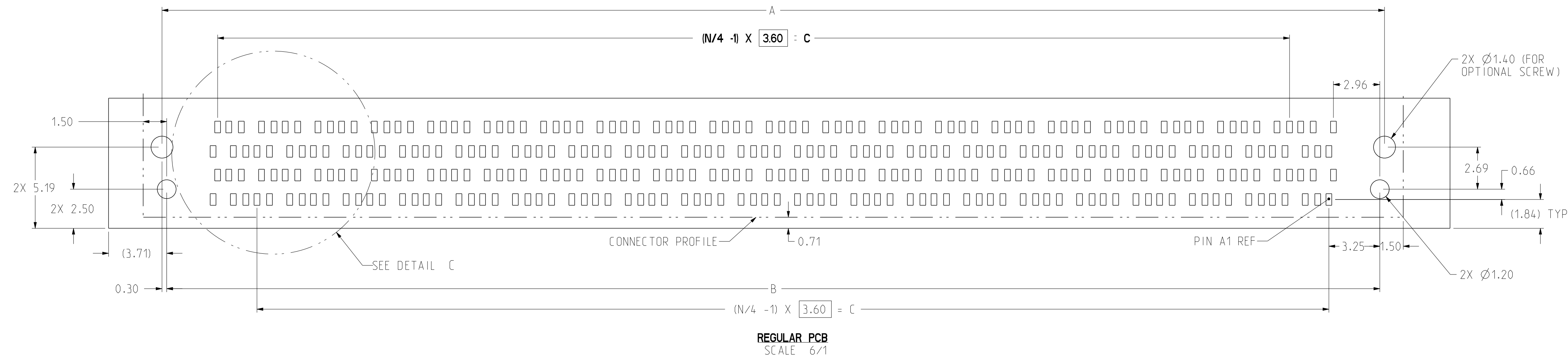

TABLE 5: TAPE AND REEL DIMENSION TABLE							
POSITION	TAPE WIDTH	CONNECTORS PER REEL	DIM A	DIM B	DIM C	DIM D	DIM E
12	32	700	28.40	14.20	12.00	18.10	19.45
12 - SHORT	32	700	28.40	14.20	12.00	15.50	15.90
20	44	700	40.40	20.20	18.60	25.00	26.90
20 - SHORT	44	700	40.40	20.20	18.60	22.40	23.35
40	72	700	68.40	34.20	36.60	43.00	44.90
40 - SHORT	72	700	68.40	34.20	36.60	40.40	41.35
60	88	400	84.40	42.20	54.60	61.00	62.90
60 - SHORT	88	400	84.40	42.20	54.60	58.40	59.35
80	104	400	100.40	50.20	72.60	79.00	80.90
80 - SHORT	104	400	100.40	50.20	72.60	76.40	77.35

**RA PLUG CARRIER TAPE FOR
12 POSITION IS SHOWN FOR REFERENCE**

