

MATERIALS AND FINISHES

BODY, CONTACT SLEEVE STAINLESS STEEL  
PLATED GOLD

FLANGE BODY STAINLESS STEEL  
PASSIVATE

RETAINING CLIP CARBON STEEL  
PLATED NICKEL

WASHER BRASS  
PLATED NICKEL

SPRING STEEL  
PLATED NICKEL

CENTER CONTACT  
PLATED GOLD SEE TABLE

SPRINGS BERYLLIUM COPPER  
PLATED GOLD

INSULATOR TEFLON

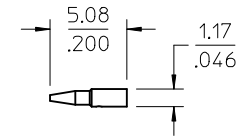
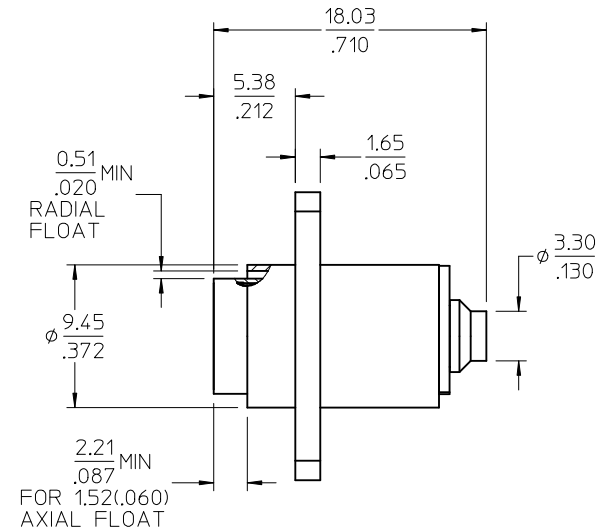
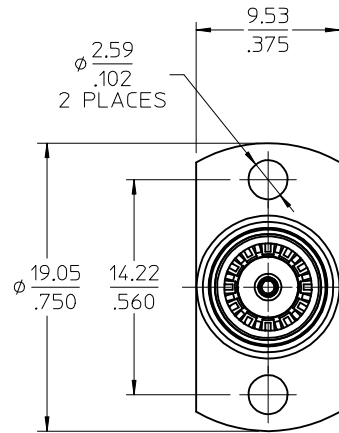
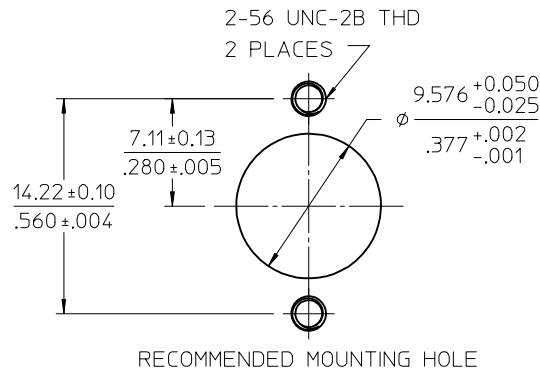
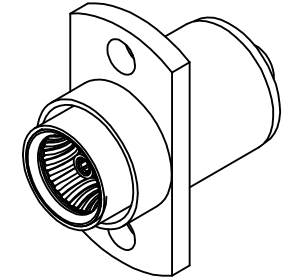
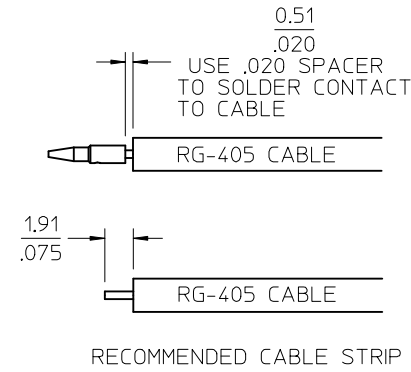
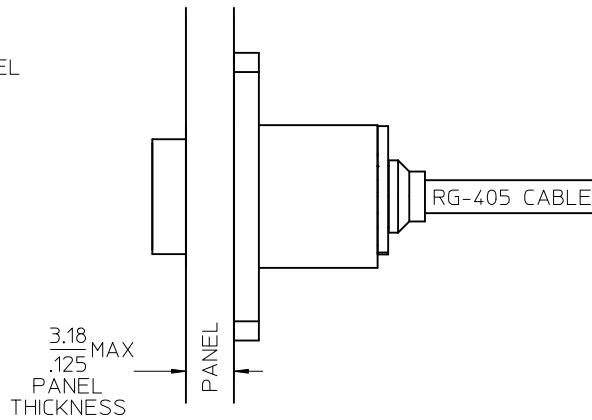

CONTACT

73298-0223	50 PER BAG	10 MICROINCHES
73298-0222	73298-0220, PARTIALLY ASSEMBLED	30 MICROINCHES
73298-0221	73298-0220, ONE PER BAG	30 MICROINCHES
73298-0220	50 PER BAG	30 MICROINCHES
PART NO.	PACKAGING	CENTER CONTACT

PS-89675-1860	ELEC/MECH PERFORMANCE
MIL-STD-348A, FIG. 321.2	INTERFACE
SPECIFICATION	DESCRIPTION

CHG: UPDATED VIEWS PER RF15-E307 EC NO: URF2016-0160 DRWR:YEH CHKD: APPR:YCHENG 2015/09/02 2015/09/07 DESCRIPTION	QUALITY SYMBOLS ▽=0 ▽=0 ▽=0
--	--------------------------------------

GENERAL TOLERANCES (UNLESS SPECIFIED) mm INCH 4 PLACES ± --- ± --- 3 PLACES ± --- ± --- 2 PLACES ± --- ± --- 1 PLACE ± --- ± --- 0 PLACE ± ± ANGULAR ± 2 ° DRAFT WHERE APPLICABLE MUST REMAIN WITHIN DIMENSIONS
--

DIMENSION STYLE MM/IN DRAWN BY JLEE02 DATE 2010/03/12 CHECKED BY SSS DATE 2010/03/15 APPROVED BY JW IENER DATE 2010/03/15 MATERIAL NO. SEE TABLE
---

SCALE 4:1 DESIGN UNITS METRIC THIRD ANGLE PROJECTION	TITLE BMA, JACK 2H FLANGE FLOAT MT, .086 50 OHM BMA-JC/F EWR-4339 <b>molex</b> DOCUMENT NO. SD-73298-022 SHEET NO. 1 OF 1
---	---

MATERIALS AND FINISHES

BODY, CONTACT SLEEVE STAINLESS STEEL  
PLATED GOLD

FLANGE BODY STAINLESS STEEL  
PASSIVATE

RETAINING CLIP CARBON STEEL  
PLATED NICKEL

WASHER BRASS  
PLATED NICKEL

SPRING STEEL  
PLATED NICKEL

CENTER CONTACT  
PLATED GOLD SEE TABLE

SPRINGS BERYLLIUM COPPER  
PLATED GOLD

INSULATOR TEFLON

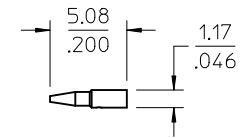
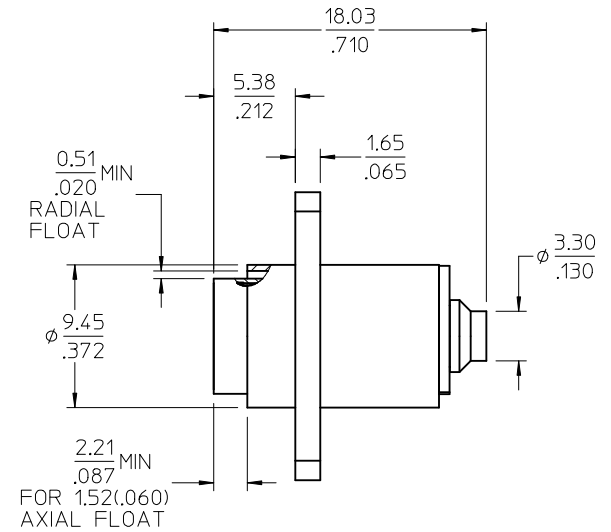
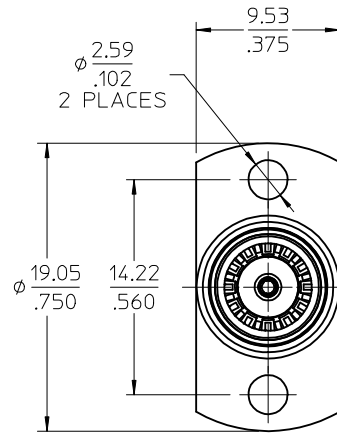
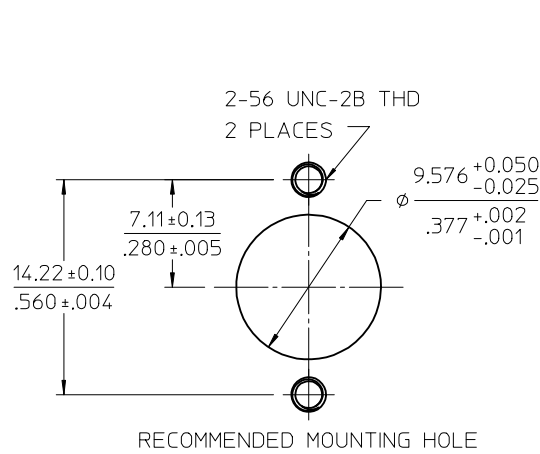
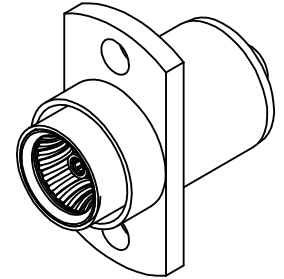
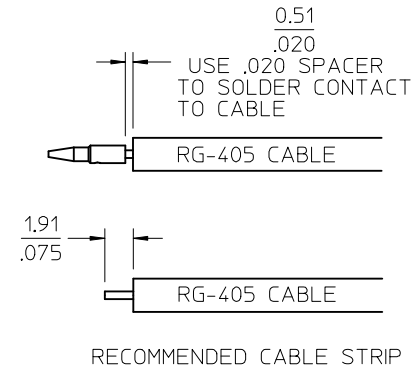
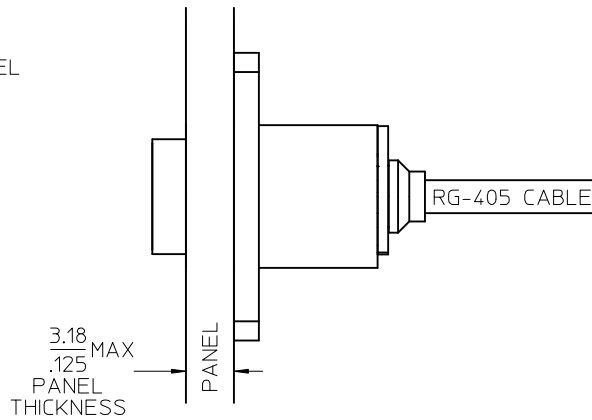

CONTACT

73298-0223	50 PER BAG	10 MICROINCHES
73298-0222	73298-0220, PARTIALLY ASSEMBLED	30 MICROINCHES
73298-0221	73298-0220, ONE PER BAG	30 MICROINCHES
73298-0220	50 PER BAG	30 MICROINCHES
PART NO.	PACKAGING	CENTER CONTACT

PS-89675-1860	ELEC/MECH PERFORMANCE
MIL-STD-348A, FIG. 321.2	INTERFACE
SPECIFICATION	DESCRIPTION

CHG: UPDATED VIEWS PER RF15-E307	EC NO: URF2016-0160	2015/09/02
DRWR:YEH	CHKD:	2015/09/07
APPR:YCHENG	DESCRIPTION	
REV	DESCRIPTION	

QUALITY SYMBOLS	GENERAL TOLERANCES (UNLESS SPECIFIED)
▽=0	mm INCH
▽=0	4 PLACES ± --- ± ---
▽=0	3 PLACES ± --- ± ---
▽=0	2 PLACES ± --- ± ---
	1 PLACE ± --- ± ---
	0 PLACE ± ±
	ANGULAR ± 2 °
	DRAFT WHERE APPLICABLE MUST REMAIN WITHIN DIMENSIONS

DIMENSION STYLE	SCALE	DESIGN UNITS	THIRD ANGLE PROJECTION
MM/IN	4:1	METRIC	
DRAWN BY	DATE	TITLE	
JLEE02	2010/03/12	BMA, JACK 2H FLANGE FLOAT MT, .086 50 OHM BMA-JC/F EWR-4339	
CHECKED BY	DATE		
SSS	2010/03/15		
APPROVED BY	DATE		
JWIENER	2010/03/15		
MATERIAL NO.	DOCUMENT NO.		
SEE TABLE	SD-73298-022		
SIZE			
C			

SHEET NO.	1 OF 1
THIS DRAWING CONTAINS INFORMATION THAT IS PROPRIETARY TO MOLEX INCORPORATED AND SHOULD NOT BE USED WITHOUT WRITTEN PERMISSION	