

TOP VIEW

R.010 [R0.25] MAX. TYP. .665 [16.89] MIN.

.525 [13.34] MIN.

RECOMMENDED PANEL CUTOUT

REVISIONS				
SYM	ZONE	ECN, ERN NO.	DATE	APPRD.
A		PROPOSAL	JAN 26.10	L.C
B		CORRECT DIMENSION	JAN 19.16	L.CHAN

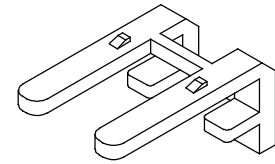

LIGHT PIPE: RJSSE-2485-01

RJSSE-2485-01 MUST BE ORDERED SEPARATELY  
RJSSE-2485-01 MUST BE PACKED SEPARATELY

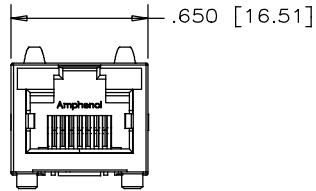

FRONT VIEW

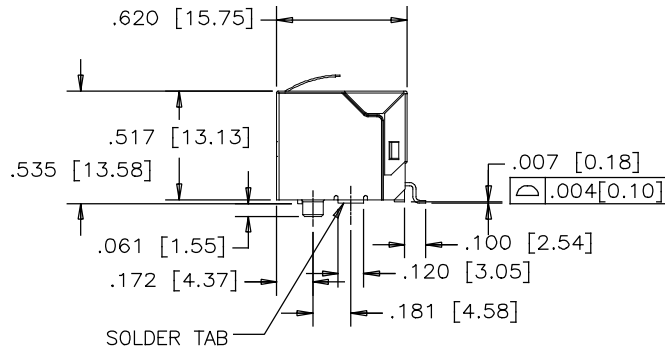

SIDE VIEW

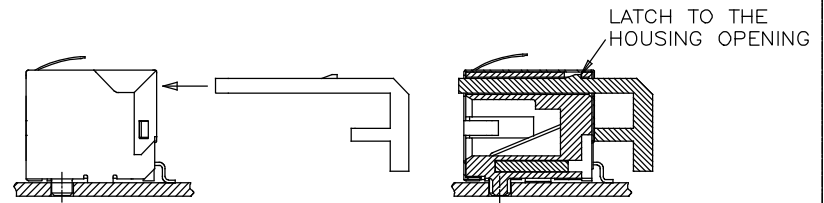

AFTER SOLDER REFLOW, LOAD LIGHT PIPE THROUGH THE CONNECTOR REAR ACCESS IN THE DIRECTION AS SHOWN

MATERIALS:  
PLASTIC HOUSING: ENGINEERING THERMOPLASTIC  
FLAMMABILITY RATING UL 94V-0

CONTACTS: PHOSPHOR BRONZE  
PLATING: 20 u" [0.508 MICRONS]  
MIN. GOLD ON MATING SURFACES.  
50 u" [1.27 MICRONS]  
MIN. NICKEL UNDERPLATE.  
100 u" [2.54 MICRONS]  
MIN. MATTE TIN ON CONTACT TAILS.

SHIELD: COPPER ALLOY  
PLATING: NICKEL

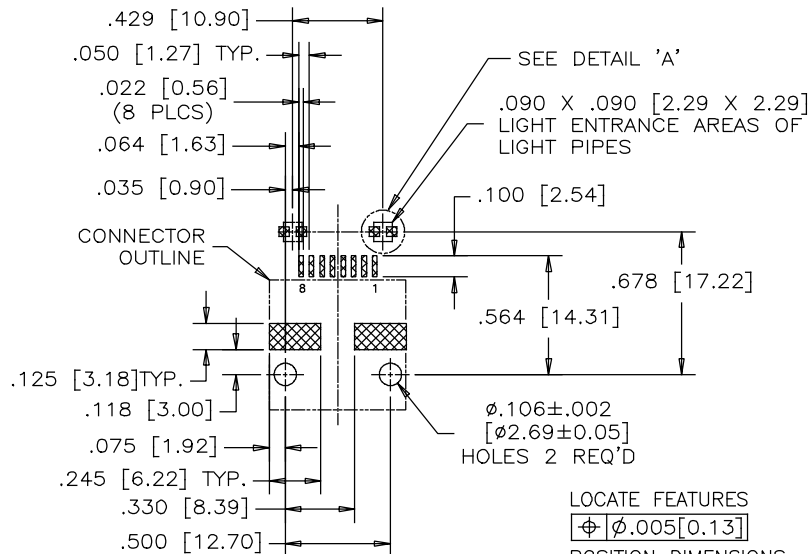

RECOMMENDED P.C.B. LAYOUT (COMPONENT SIDE OF BOARD)

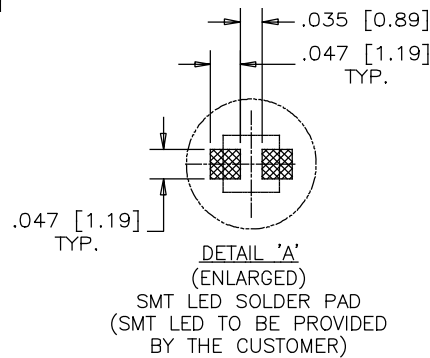

PART NUMBER: RJSSE-5582-01T

MATERIAL -----	DRAWN	MT	DATE	Amphenol Canada Corp.
	DESIGNED	MT	JAN 26.10	
FINISH -----	CHECKED	L.C	JAN 26.10	TITLE
	I. E. APPRD. Q. A. APPRD. DWG. APPRD. ENG. REL. NO. REF.			SINGLE PORT, SURFACE MOUNT RJ45 8 POSITION, 8 CONTACTS, SHIELDED WITHOUT LIGHT PIPE, TAPE & REEL PACKAGING
DIMENSIONS ARE IN INCHES [mm]			CODE ID. NO. 03554	DWG. C
SCALE 2:1			WT. -----	SURF. -----
SHEET 1 OF 1				REV. B

THIS DOCUMENT CONTAINS PROPRIETARY INFORMATION AND SUCH INFORMATION MAY NOT BE DISCLOSED TO OTHERS FOR ANY PURPOSE OR USED FOR MANUFACTURING PURPOSES WITHOUT WRITTEN PERMISSION FROM AMPHENOL CANADA CORP.

REVISIONS				
SYM	ZONE	ECN, ERN NO.	DATE	APPRD.
A		PROPOSAL	Feb 27.09	L.C
B		CORRECT DIMENSION	JAN 19.16	L.CHAN

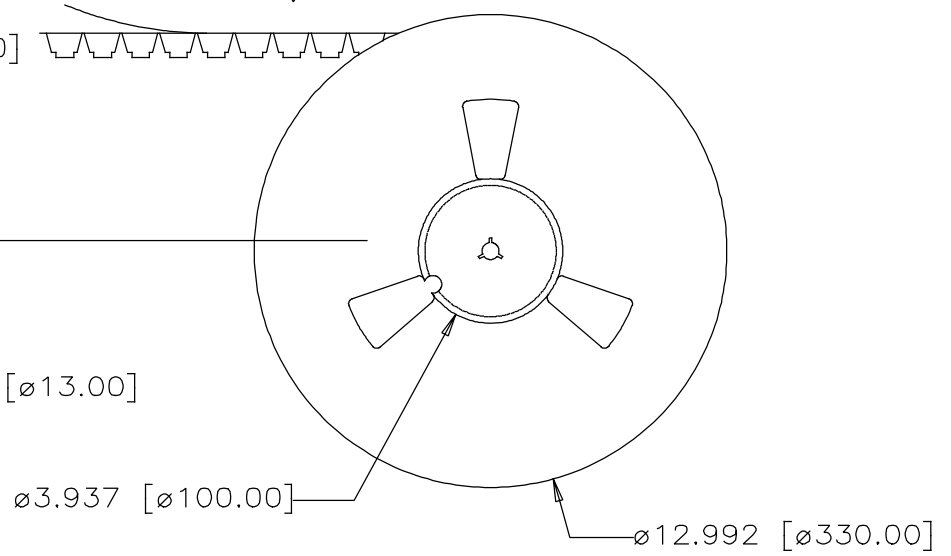
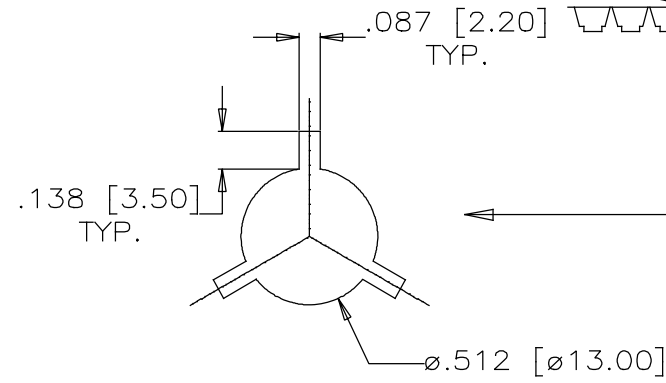
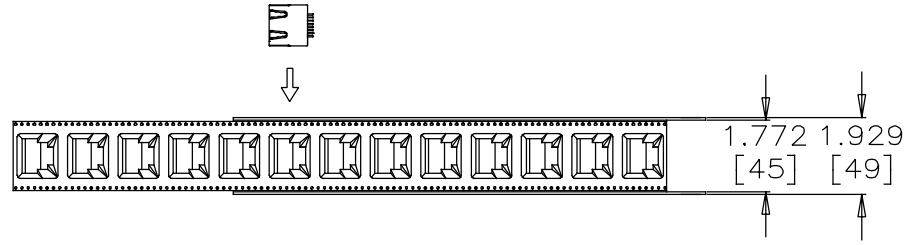
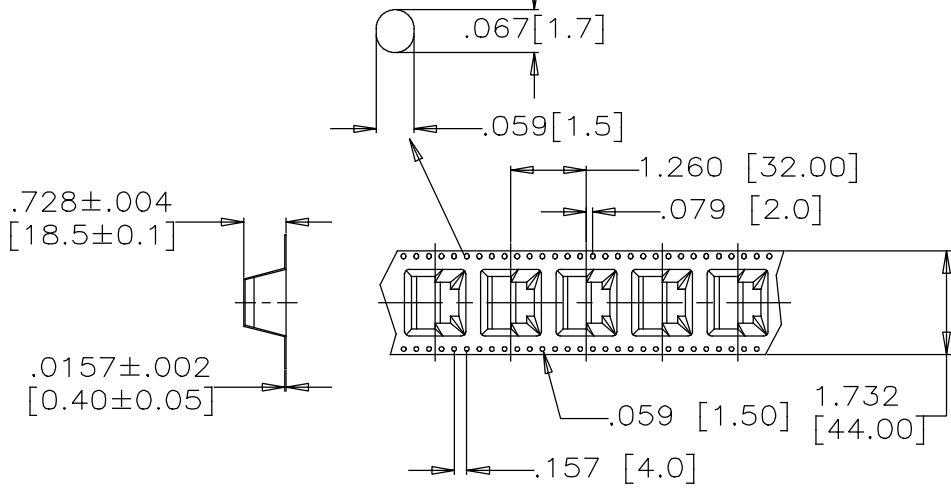

PACKAGING NOTES:

1. ONE REEL SHOULD HOLD 100 CONNECTORS.
2. 10 EMPTY CAVITIES FOR BOTH TOP AND BOTTOM OF THE CARRIER.
3. A FULLY LOADED CARTON SHOULD CONTAIN 6 REELS (600 PCS) OF CONNECTOR.

MATERIAL	DRAWN	MT	DATE	JAN 26.10
	DESIGNED	MT	JAN 26.10	
FINISH	CHECKED	L.C	JAN 26.10	
	I. E. APPRD.			
	Q. A. APPRD.			
	DWG. APPRD.			
	ENG. REL. NO.			
	REF.			
	DIMENSIONS ARE IN	INCHES [mm]	CODE ID. NO.	03554

Amphenol Canada Corp.			
TITLE SINGLE PORT, SURFACE MOUNT RJ45 8 POSITION, 8 CONTACTS, SHIELDED WITHOUT LIGHT PIPE, TAPE & REEL PACKAGING			
DWG	DRAWING NO.	P-RJSSE-5582-01T	REV. B
SCALE	WT.	SURF.	SHEET 2 OF 2

THIS DOCUMENT CONTAINS PROPRIETARY INFORMATION AND SUCH INFORMATION MAY NOT BE DISCLOSED TO OTHERS FOR ANY PURPOSE OR USED FOR MANUFACTURING PURPOSES WITHOUT WRITTEN PERMISSION FROM AMPHENOL CANADA CORP.