

HARTING har-bus® HM female connector



General information

Design	IEC 61076-4-101	type: monoblock 47
No. of contacts	max. 220 or 200 with upper shield	
Contact spacing	2,0mm	
Test voltage	750V AC	
Contact resistance	max. 20mOhm	
Insulation resistance	min. 10 ¹⁰ Ohm	
Working current	1A at 70°C (see derating diagram)	
Temperature range	-55°C ... +125°C	
Termination technology	press-in	
Clearance & creepage distance	0,6 mm each for free connector	
Insertion and withdrawal force	insertion force per contact:	0,75N max.
	withdrawal force per contact:	0,15N min.
Mating cycles	acc. to performance level, see table below	
UL file	E102079	
RoHS - compliant	Yes	
Leadfree	Yes	

Insulator material

Material	LCP (liquid crystalline polymer, glass fiber reinforcement 30%)
Colour	nature
UL classification	UL 94-V0
Material group acc. to IEC 60664-1	IIIa (175 ≤ CTI < 400)

Contact material

Contact material	Copper alloy
Treatment contact zone	Bellcore recommended lubricant (PPE)
Plating press-in zone	Ni
Plating contact zone	acc. to performance level, see table below
Shielding contact zone	acc. to performance level, see table below

performance level	mating cycles		plating contact zone	shielding contact zone
	acc. to IEC 61076-4-101	complementary acc. to IEC 61076-4-101		
1	500		<i>Au over Ni</i>	<i>noble metal over Ni</i>
2	250		<i>Au over Ni</i>	<i>noble metal over Ni</i>
NM30 (S4)		500	min. 0,76µm (30pinch) noble metal (alloy) over Ni	
Au30		500	min. 0,76µm (30pinch) Au over Ni	not available
Au50		500	min. 1,27µm (50pinch) Au over Ni	

Standard plating options highlighted in *italic*, other plating options are available on request.

Recommended configuration of plated through holes for press-in termination

In addition to the hot-air-level (HAL), other PCB surfaces are getting more important. Due to their different properties - such as mechanical strength and coefficient of friction - we recommend the following configuration of PCB through holes.

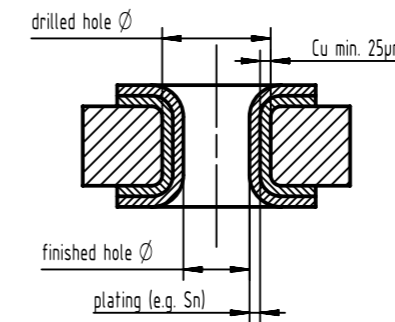

Tin plated PCB (HAL) acc. to EN 60352-5	Drilled hole Ø	0,7±0,02mm
	Sn	max. 15µm
	plated hole Ø	0,60 - 0,65mm
Chemical tin plated PCB	Drilled hole Ø	0,7±0,02mm
	Sn	min. 0,8µm
	plated hole Ø	0,60 - 0,65mm
Gold /Nickel plated PCB	Drilled hole Ø	0,7±0,02mm
	Ni	3 - 7µm
	Au	0,05 - 0,12µm
	plated hole Ø	0,60 - 0,65mm
Silver plated PCB	Drilled hole Ø	0,7±0,02mm
	Ag	0,1 - 0,3µm
	plated hole Ø	0,60 - 0,65mm
Copper plated PCB (OSP)	Drilled hole Ø	0,7±0,02mm
	plated hole Ø	0,60 - 0,65mm

Assembly instructions

It is highly recommended to use HARTING press-in tools to ensure a reliable press-in process. Please refer to the catalogue for tools, machines and further information about the press-in process.

Circuit density

When using the specified diameter of the finished through hole according to IEC 61 076-4-101 (0.6 ± 0.05mm) with an appropriate annular ring, the remaining distance between the rings is about 1mm.

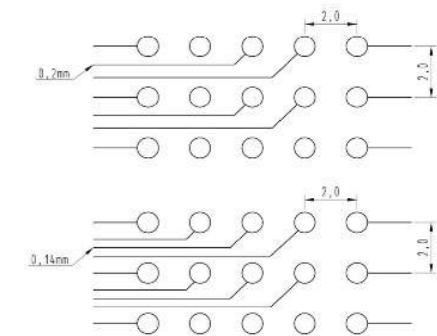

Under the condition that the width of the track and the space between should be equal, two tracks of 0.2mm width or three tracks of 0.14mm width can be placed between two rings.

Typical designs are shown in the drawing on the right side.

Derating diagram acc. to IEC 60512-5 (Current carrying capacity)

The current carrying capacity is limited by maximum temperature of materials for inserts and contacts including terminals. The current capacity curve is valid for continuous, non interrupted current loaded contacts of connectors when simultaneous power on all contacts is given, without exceeding the maximum temperature.

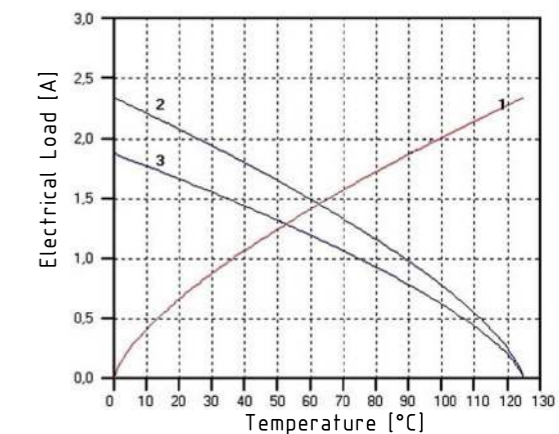

Control and test procedures according to DIN IEC 60512-5

Curve 1 shows raise in temperature
Curve 2 shows nominal derating Date Name
Curve 3 shows reduced values as per IEC512

	All Dimensions in mm Original Size DIN A3	Scale 1:1	Free size tol.	Ref. Sub.
	All rights reserved Department EL PD	Created by STORCK	Inspected by LEHNERT	Standardisation Date 2021-12-13
HARTING D-32339 Espelkamp	Title har-bus® HM female connector			State Final Release
Type DS				Number 17002200102
				Doc-Key / ECM-Nr. 100580926/UGD/000/C 500000207997
				Rev. C
				Page 1/1