

REVISIONS			
REV	DATE	BY	APPD
A1	08.03.06	konery	bruner
A2	04.09.06	konery	bruner
A3	15.03.2014	JB,H	PJ
A4	15.03.2015	JB,H	BK

- 1 CONTACT AREA GOLD PLATED MIN. 0.8µm OVER MIN. 1.3µm Ni- LAYER
REST TIN PLATED MIN. 2µm
Kontaktzone vergoldet min. 0.8µm über min. 1.3µm Ni - Zwischenschicht
Rest verzinkt min. 1µm
- 2 CONTACT AREA AND TOUCHING AREA TO CANTILEVER SPRING GOLD PLATED MIN. 0.8µm
OVER MIN. 1.3µm Ni- LAYER, REST TIN PLATED MIN. 2µm
Kontaktzone und Anlagefläche zur überfeder vergoldet min. 0.8µm
über min. 1.3µm Ni - Zwischenschicht, rest verzinkt min. 1µm
- 3 CANTILEVER SPRING INSIDE AND OUTSIDE 0.8µm Au
überfeder inner und außen 0.8µm Au
- 4 AFTER CUT-OFF FROM THE CARRIER STRIP
Nach trennen vom Trägerstreifen
- 5 CURRENT LOADING MAX. 6A AT Tu=25°C
Strombelastung max. 6A bei Tu=25°C
- 6 BLADE THICKNESS 0.8±0.03 DIN 46244
Messerstärke 0.8±0.03 DIN 46244
- 7 OBSOLETE

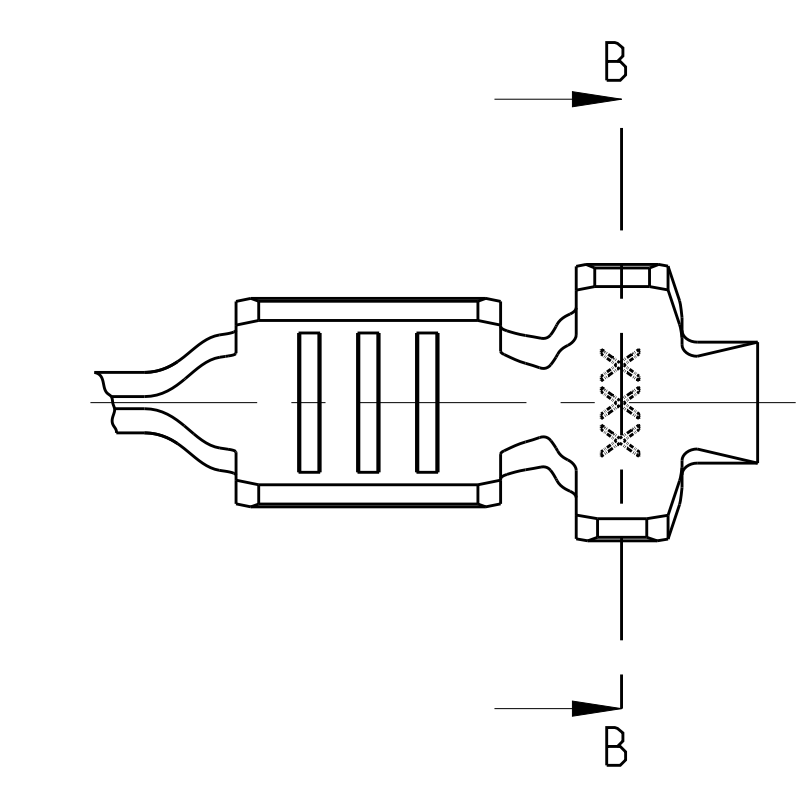
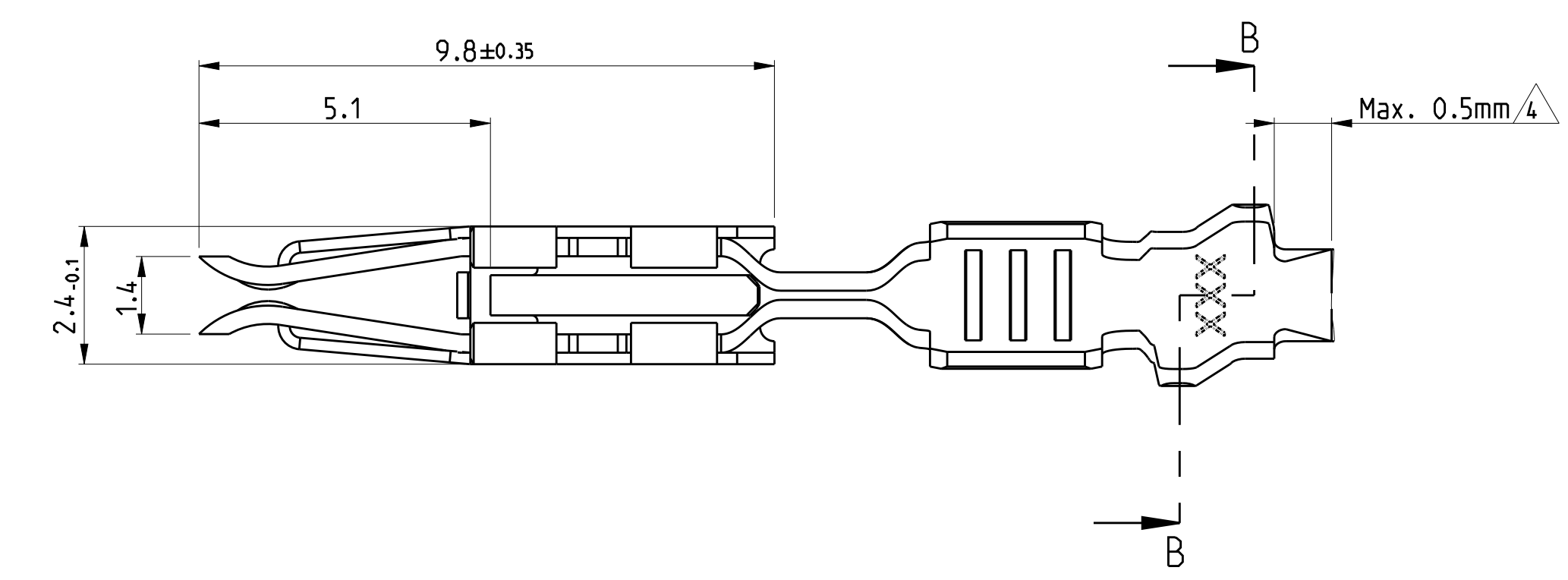
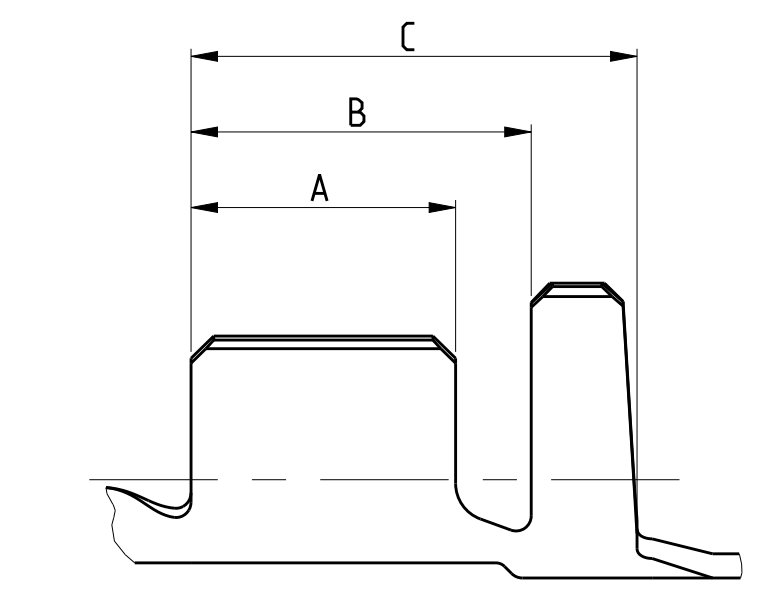
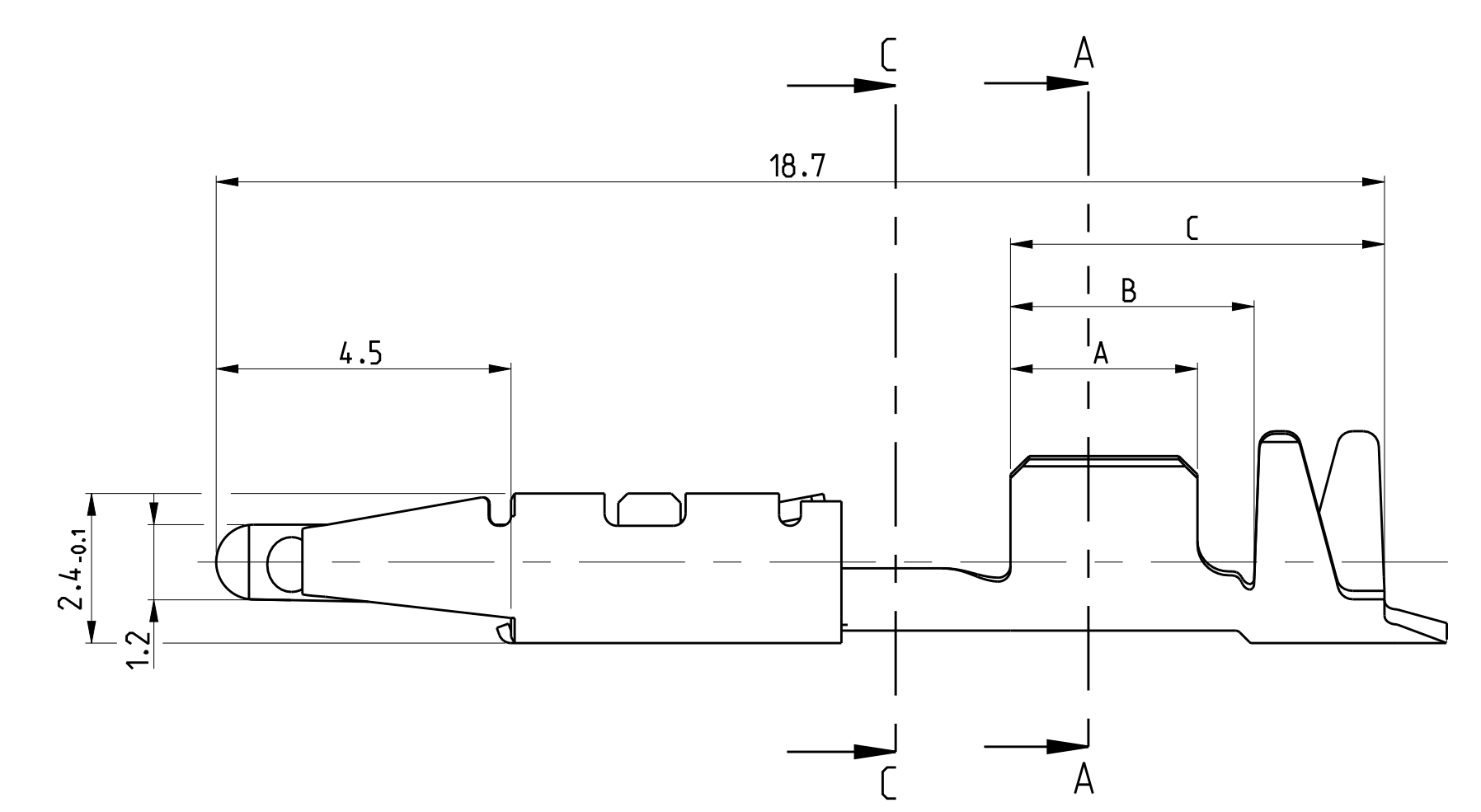

FORM A

FORM B

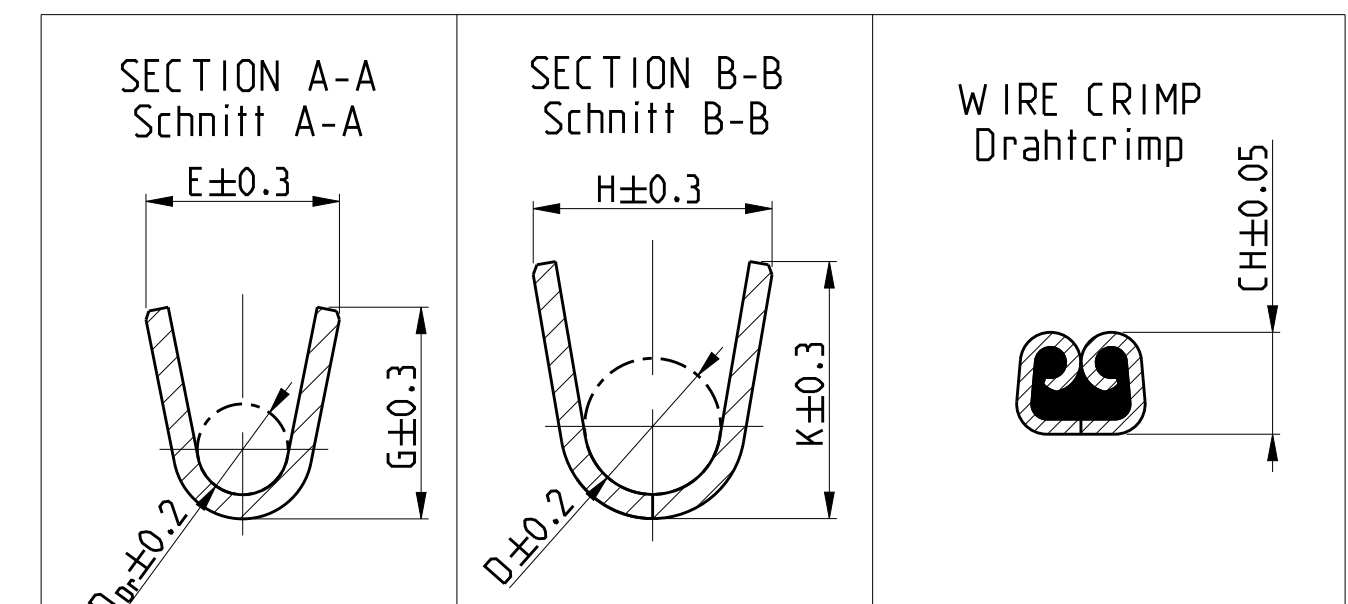

TE ORDER-NO.	REV	MATERIAL	SURFACE	WIRE RANGE	INSULATION	WIRE CRIMP	STRIP FORM	WIRE CRIMP HEIGHT	APPLICATION TOOL	HAND TOOL	A	B	C	
STRIP FROM Bandware		Workstoff	Oberfläche	Drahtgrößen Bereich (mm²)	Isolations Ø (mm)	Drahtcrimp	INSUL.-CRIMP Isol.- Crimp Bandware	Drahtcrimp - Höhe CH	Ansschlag-WKZ	Handzange				
											CRIMP DIMENSION (mm) Crimp abmessungen (mm)			
											EXTRACTION TOOL Ausdrückwerkzeug No. 5-1579007-5			
929954-4	D	CuFe2	PRE-TINNED min. 1µm	1.0-1.5 FLR	max. 2.3	E = 2.8 G = 3.0 Dcr = 1.3	H = 3.7 K = 3.9 D = 2.1	FORM B	1.0mm²±1.47 1.25mm²±1.56 1.5mm²±1.65 Double Crimp Doppelanschlag	878469-2	539635-1 with die set 539739-2	3.5	4.5	5.9
929954-3	D	CuFe2	PRE-TINNED min. 1µm	1.0-1.5 FLR	max. 2.3	E = 2.8 G = 3.0 Dcr = 1.3	H = 3.7 K = 3.9 D = 2.1	FORM B	0.35±0.75 0.35±1.0 0.50±0.50 0.50±0.75 0.50±1.0	878469-2	539635-1 with die set 539739-2	3.5	4.5	5.9
929954-2	D	CuSn4	PRE-TINNED min. 1µm	1.0-1.5 FLR	max. 2.3	E = 2.8 G = 3.0 Dcr = 1.3	H = 3.7 K = 3.9 D = 2.1	FORM B	0.35±0.75 0.35±1.0 0.50±0.50 0.50±0.75 0.50±1.0	878469-2	539635-1 with die set 539739-2	3.5	4.5	5.9
929954-1	D	CuSn4	PRE-TINNED min. 1µm	1.0-1.5 FLR	max. 2.3	E = 2.8 G = 3.0 Dcr = 1.3	H = 3.7 K = 3.9 D = 2.1	FORM B	0.35±0.75 0.35±1.0 0.50±0.50 0.50±0.75 0.50±1.0	878469-2	539635-1 with die set 539739-2	3.5	4.5	5.9
929952-8	D	CuFe2	PRE-TINNED min. 1µm	0.5-1.0 FLR	max. 2.0	E = 2.6 G = 2.8 Dcr = 1.2	H = 3.2 K = 3.4 D = 1.8	FORM A	0.5mm²±1.18 0.75mm²±1.27 1.0mm²±1.36 Double Crimp Doppelanschlag	878468-2	539635-1 with die set 539739-2	3	3.9	6
929952-7	D	CuSn4	PRE-TINNED min. 1µm	0.5-1.0 FLR	max. 2.0	E = 2.6 G = 2.8 Dcr = 1.2	H = 3.2 K = 3.4 D = 1.8	FORM A	0.35±0.35 0.35±0.50 0.50±0.50	878468-2	539635-1 with die set 539739-2	3	3.9	6
929952-4	D	CuFe2	PRE-TINNED min. 1µm	0.5-1.0 FLR	max. 2.0	E = 2.6 G = 2.8 Dcr = 1.2	H = 3.2 K = 3.4 D = 1.8	FORM A	0.35±0.35 0.35±0.50 0.50±0.50	878468-2	539635-1 with die set 539739-2	3	3.9	6
929952-3	D	CuFe2	PRE-TINNED min. 1µm	0.5-1.0 FLR	max. 2.0	E = 2.6 G = 2.8 Dcr = 1.2	H = 3.2 K = 3.4 D = 1.8	FORM A	0.35±0.35 0.35±0.50 0.50±0.50	878468-2	539635-1 with die set 539739-2	3	3.9	6
929952-2	D	CuSn4	PRE-TINNED min. 1µm	0.5-1.0 FLR	max. 2.0	E = 2.6 G = 2.8 Dcr = 1.2	H = 3.2 K = 3.4 D = 1.8	FORM A	0.35±0.35 0.35±0.50 0.50±0.50	878468-2	539635-1 with die set 539739-2	3	3.9	6
929952-1	D	CuSn4	PRE-TINNED min. 1µm	0.5-1.0 FLR	max. 2.0	E = 2.6 G = 2.8 Dcr = 1.2	H = 3.2 K = 3.4 D = 1.8	FORM A	0.35±0.35 0.35±0.50 0.50±0.50	878468-2	539635-1 with die set 539739-2	3	3.9	6
929950-4	C	CuFe2	PRE-TINNED min. 1µm	0.2-0.5 FLR	max. 1.6	E = 2.1 G = 2.1 Dcr = 0.8	H = 2.8 K = 2.8 D = 1.4	FORM A	0.2mm²±0.98 0.25mm²±1.00 0.35mm²±1.05 0.5mm²±1.12	878467-2	539635-1 with die set 539739-2	2.5	3.75	5.9
929950-3	C	CuFe2	PRE-TINNED min. 1µm	0.2-0.5 FLR	max. 1.6	E = 2.1 G = 2.1 Dcr = 0.8	H = 2.8 K = 2.8 D = 1.4	FORM A	0.2mm²±0.98 0.25mm²±1.00 0.35mm²±1.05 0.5mm²±1.12	878467-2	539635-1 with die set 539739-2	2.5	3.75	5.9
929950-2	C	CuSn4	PRE-TINNED min. 1µm	0.2-0.5 FLR	max. 1.6	E = 2.1 G = 2.1 Dcr = 0.8	H = 2.8 K = 2.8 D = 1.4	FORM A	0.2mm²±0.98 0.25mm²±1.00 0.35mm²±1.05 0.5mm²±1.12	878467-2	539635-1 with die set 539739-2	2.5	3.75	5.9
929950-1	C	CuSn4	PRE-TINNED min. 1µm	0.2-0.5 FLR	max. 1.6	E = 2.1 G = 2.1 Dcr = 0.8	H = 2.8 K = 2.8 D = 1.4	FORM A	0.2mm²±0.98 0.25mm²±1.00 0.35mm²±1.05 0.5mm²±1.12	878467-2	539635-1 with die set 539739-2	2.5	3.75	5.9
928939-4	G	CuFe2	PRE-TINNED min. 1µm	0.35-0.75 FLR	max. 1.9	E = 2.3 G = 2.4 Dcr = 1.0	H = 3.2 K = 3.1 D = 1.6	FORM A	0.35mm²±1.09 0.50mm²±1.16 0.75mm²±1.27 Double Crimp Doppelanschlag	878376-2	539635-1 with die set 539739-2	2.9	3.75	5.9
928939-3	G	CuFe2	PRE-TINNED min. 1µm	0.35-0.75 FLR	max. 1.9	E = 2.3 G = 2.4 Dcr = 1.0	H = 3.2 K = 3.1 D = 1.6	FORM A	0.35±0.75	878376-2	539635-1 with die set 539739-2	2.9	3.75	5.9
928939-2	G	CuSn4	PRE-TINNED min. 1µm	0.35-0.75 FLR	max. 1.9	E = 2.3 G = 2.4 Dcr = 1.0	H = 3.2 K = 3.1 D = 1.6	FORM A	0.35±0.75	878376-2	539635-1 with die set 539739-2	2.9	3.75	5.9
928939-1	G	CuSn4	PRE-TINNED min. 1µm	0.35-0.75 FLR	max. 1.9	E = 2.3 G = 2.4 Dcr = 1.0	H = 3.2 K = 3.1 D = 1.6	FORM A	0.35±0.75	878376-2	539635-1 with die set 539739-2	2.9	3.75	5.9

SECTION C-C
Schnitt C-C

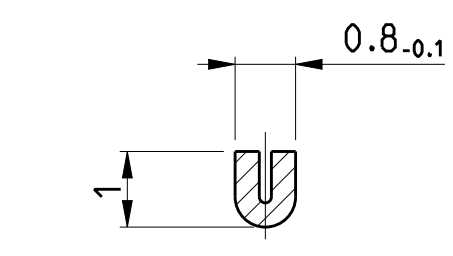

THIS DRAWING IS NOT SUBJECT TO CONSTANT CHANGING SERVICE AND DOES NOT LAY CLAIM TO BE COMPLETE. FOR DEFINITE SPECIFICATION SEE RESPECTIVE TE CUSTOMER DRAWINGS. FURTHER VERSIONS ON INQUIRY.

Diese Zeichnung unterliegt nicht dem ständigen Änderungsdienst und erhebt keinen anspruch auf vollständigkeit. verbindliche angaben sinder jeweiligen TE-kundenzeichnung zu entnehmen. weiter ausföhrungen auf anfrage

THIS DRAWING IS A CONTROLLED DOCUMENT.		DATE: 29.12.04	BY: T. Konery	APPD: M. Brunner
DIMENSIONS: (mm)		SCALE: 1:1	SHEET: 1 of 1	
MATERIAL: SEE TABLE		PRODUCT SPEC: 108-18024	APPLICATION SPEC: 114-18163	
SEE TABLE		WEIGHT: -	RESTRICTION: -	
Customer Drawing		SCALE: 5:1	REV: A4	