

THIS DRAWING IS SUPPLIED FOR INFORMATION ONLY. DESIGN FEATURES, SPECIFICATIONS AND PERFORMANCE DATA SHOWN HEREON ARE THE PROPERTY OF THE AMPHENOL CORPORATION. NO RIGHTS OF REPRODUCTION ARE IMPLIED. ALL DIMENSIONS ARE SUBJECT TO NORMAL MANUFACTURING VARIATIONS.

Customer Drawing

REVISIONS						
REV	ZONE	ECO	DESCRIPTION	DATE	BY	APPR
A	--	--	Add Information: Accepted Unshielding Wire	03/09/15	RW	EC
J	--	--	Redefine cable size	05/17/18	YM	JL
K	--	--	Add specification description	08/22/18	ST	JL
L	--	--	Redefine cable tolerances	09/28/18	ST	JL
M	--	--	Cancel panel requirements	10/30/19	Steven	JL

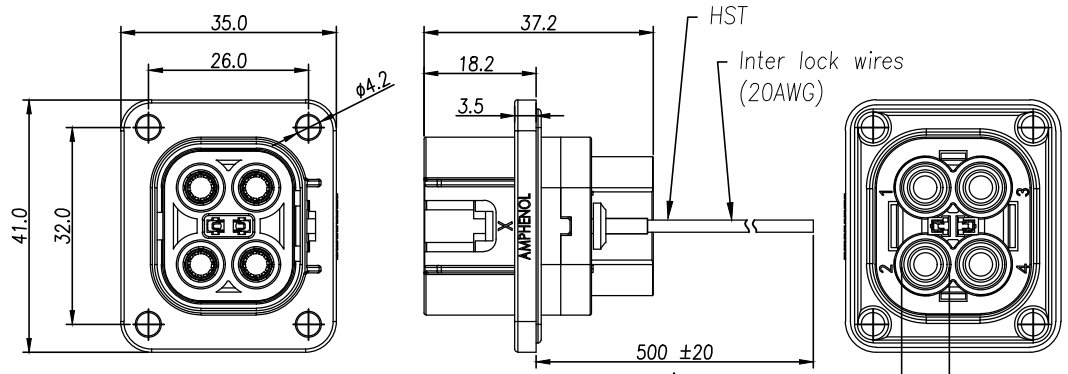
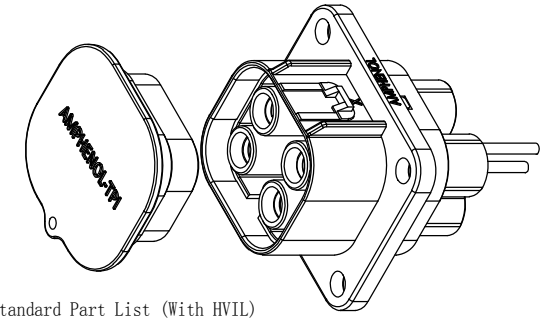
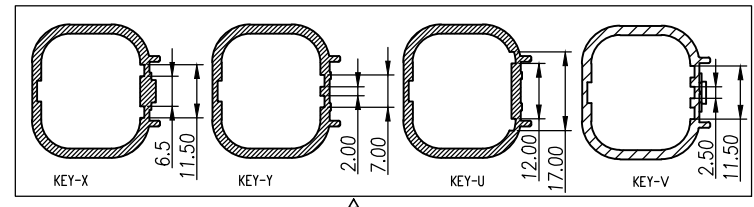

Standard Part List (With HVIL)

P/N	Model NO.	Dimension "A"	Cable size	Accepted cable OD
AC-HA002960	PL084X-41-2.5	φ3.70mm	2.5mm <sup>2</sup>	<φ7.5mm
AC-HA002961	PL084Y-41-2.5			
AC-HA002962	PL084U-41-2.5	φ4.57mm	4mm <sup>2</sup>	<φ7.5mm
AC-HA010400	PL084V-41-2.5			
AC-HA002963	PL084X-41-4	φ4.57mm	4mm <sup>2</sup>	<φ7.5mm
AC-HA002964	PL084Y-41-4			
AC-HA002965	PL084U-41-4	φ5.80mm	6mm <sup>2</sup>	<φ7.5mm
AC-HA010401	PL084V-41-4			
AC-HA002966	PL084X-41-6	φ5.80mm	6mm <sup>2</sup>	<φ7.5mm
AC-HA002967	PL084Y-41-6			
AC-HA002968	PL084U-41-6	φ5.80mm	6mm <sup>2</sup>	<φ7.5mm
AC-HA010402	PL084V-41-6			

Standard Part List (Without HVIL)

P/N	Model NO.	Dimension "A"	Cable size	Accepted cable OD
AC-HA002951	PL084X-40-2.5	φ3.70mm	2.5mm <sup>2</sup>	<φ7.5mm
AC-HA002952	PL084Y-40-2.5			
AC-HA002953	PL084U-40-2.5	φ4.57mm	4mm <sup>2</sup>	<φ7.5mm
AC-HA010403	PL084V-40-2.5			
AC-HA002954	PL084X-40-4	φ4.57mm	4mm <sup>2</sup>	<φ7.5mm
AC-HA002955	PL084Y-40-4			
AC-HA002956	PL084U-40-4	φ5.80mm	6mm <sup>2</sup>	<φ7.5mm
AC-HA010404	PL084V-40-4			
AC-HA002957	PL084X-40-6	φ5.80mm	6mm <sup>2</sup>	<φ7.5mm
AC-HA002958	PL084Y-40-6			
AC-HA002959	PL084U-40-6	φ5.80mm	6mm <sup>2</sup>	<φ7.5mm
AC-HA010405	PL084V-40-6			

- Notes:
- Surface Planeness of panel should be less than or equal to 0.2mm.
  - Surface Roughness of panel should be Ra 3.2 or better.

规格参数 (Spec.):

- 工作温度 Operating temperature: -40° C ~ +125° C.
- 带高压互锁 Electrical interlock (HVIL).
- 额定电流 Current rating (connector only): 2.5mm<sup>2</sup>: 25A, 4mm<sup>2</sup>: 35A, 6mm<sup>2</sup>: 45A; HVIL: 5A (20AWG).
- 额定电压 Operating voltage: Power: 1000 VDC; Signal: 60 VDC.
- 耐电压 Dielectric withstanding voltage:
  - 与插头对插后, Pin与铁壳之间 After mating, between pin and metal shell: 5000 VDC 60S 漏电流 < 5mA.
  - 与插头对插后, Pin与HVIL之间 After mating, between pin and HVIL: 5000 VDC 60S 漏电流 < 5mA.
  - 与插头对插后, HVIL与铁壳之间 After mating, between HVIL and metal shell: 500 VDC 60S 漏电流 < 5mA.
  - 与插头对插前, 两个HVIL端子之间耐压 Before mating, between two HVIL terminals: 500 VDC 60S 漏电流 < 5mA.
- 防护等级 Protection Class: IP67 (水深1m, 浸泡0.5h) & IP2X.
- 阻燃等级 Flame Rating 绝缘件 UL94-V0 密封件 UL94-HB
- 电磁屏蔽 Shielding.
- 机械寿命 Mating cycle: 100 Min.
- 带自动二次锁扣 Automatic secondary lock.
- 接非屏蔽线 Accepte Unshielding Wire.
- 推荐法兰盘螺丝安装扭矩 Recommended Screw Assembly Torque on Flange: 1.6~2.4 Nm.

面板安装孔尺寸  
Panel Size

订购信息 Ordering Information

PL08 4 X - 4 1 - 6

键位 Key "X" "Y" "U" "V"	高压互锁 HVIL 0, 不带互锁 No HVIL 1, 带互锁 With HVIL	线缆大小 Cable Size "6"=6mm <sup>2</sup> "4"=4mm <sup>2</sup> "2.5"=2.5mm <sup>2</sup>
------------------------------------	--	---

	Amphenol Technical Products International Asia.					
	第三角投影 THIRD ANGLE PROJECTION	页面 SHEET	幅面 SIZE	版次 REV.	比例 SCALE	PART NAME: PwrLok 4.0mm 4POS Rept Conn
	1 of 2	A3	M			DWG NO: PL084-40
签名 SIGNATURE Steven	日期 DATE 10/30/19	UNLESS OTHERWISE SPECIFIED 1) All dimensions are in metric(mm). 2) Tolerances are as follows: 0 PL DEC ±1.00 1 PL DEC ±0.50 2 PL DEC ±0.20			CUST PART #: N/A	CUST REV. -
制图 DRAWN	审核 CHECKED	批准 APPROVAL				

THIS DRAWING IS SUPPLIED FOR INFORMATION ONLY. DESIGN FEATURES, SPECIFICATIONS AND PERFORMANCE DATA SHOWN HEREON ARE THE PROPERTY OF THE AMPHENOL CORPORATION. NO RIGHTS OF REPRODUCTION ARE IMPLIED. ALL DIMENSIONS ARE SUBJECT TO NORMAL MANUFACTURING VARIATIONS.

REVISIONS						
REV	ZONE	ECO	DESCRIPTION	DATE	BY	APPR
K	--	--	Add specification description	08/22/18	ST	JL
L	--	--	Redefine cable tolerances	09/28/18	ST	JL
M	--	--	Cancel panel requirements	10/30/19	Steven	JL

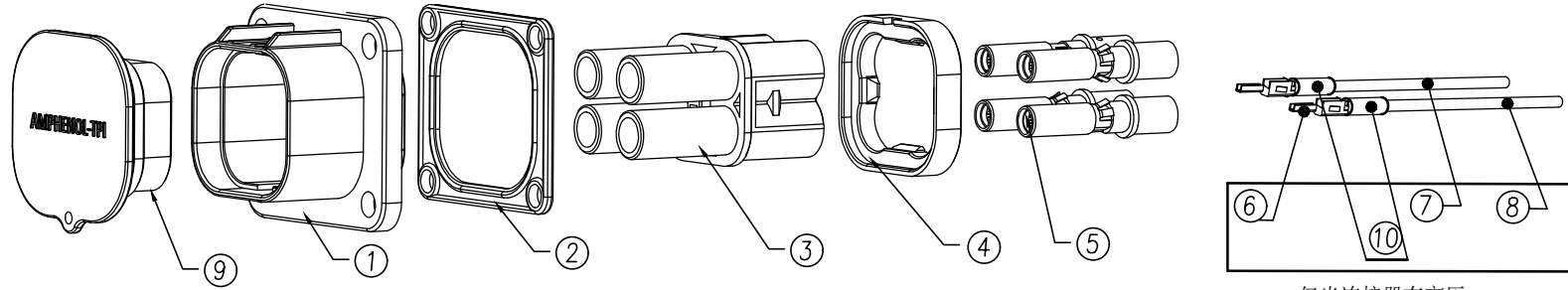

仅当连接器有高压互锁功能时安装

10	HST H-2(Z) 2.0 BK	2		
9	PL3.6 4POS Rept Dust Cap	1	LDPE	
8	20AWG RE	A/R	ETFE	
7	20AWG BK	A/R	ETFE	
6	Mini-Fit Crimp Pin18-24AWG	2	铜合金	镀锡
5	PwrLok Soc 4mm	4	紫铜	镀锡3~5um
4	3.6mm, 4POS Cover for Rcpt	1	PA66	
3	3.6mm, 4POS Housing	1	PA66	
2	PwrLok Gasket 4POS 3.6mm	1	硅橡胶	
1	PwrLok Shell Rept	1	锌合金	镀镍5~8um
序号	名称	数量	材料	表面处理

MATERIALS LIST

	Amphenol Technical Products International Asia.					PART NAME: PwrLok 4.0mm 4POS Rept Conn	
	第三角投影 THIRD ANGLE PROJECTION	页次 SHEET 2 of 2	幅面 SIZE A3	版次 REV. M	比例 SCALE	DWG NO: PL084-40	
签名 SIGNATURE Steven	日期 DATE 10/30/19	UNLESS OTHERWISE SPECIFIED 1) All dimensions are in metric(mm). 2) Tolerances are as follows: 0 PL DEC ±1.00 1 PL DEC ±0.50 2 PL DEC ±0.20			CUST PART #: N/A		
审核 CHECKED	批准 APPROVAL	Angles ±1°			CUST REV. -		

THIS DRAWING IS SUPPLIED FOR INFORMATION ONLY. DESIGN FEATURES, SPECIFICATIONS AND PERFORMANCE DATA SHOWN HEREON ARE THE PROPERTY OF THE AMPHENOL CORPORATION. NO RIGHTS OF REPRODUCTION ARE IMPLIED. ALL DIMENSIONS ARE SUBJECT TO NORMAL MANUFACTURING VARIATIONS.

Customer Drawing

Amphenol TPI  
2019-10-30  
REGISTERED COPY

REVISIONS					
REV	ZONE	ECO	DESCRIPTION	DATE	BY APPR
A	---	---	Add information: Accepted Unshielding Wire	03/09/15	RW EC
J	---	---	Redefine cable size	05/17/16	YM JL
K	---	---	Add specification description	08/22/18	ST JL
L	---	---	Redefine cable tolerances	09/28/18	ST JL
M	---	---	Cancel panel requirements	10/30/19	Steven JL

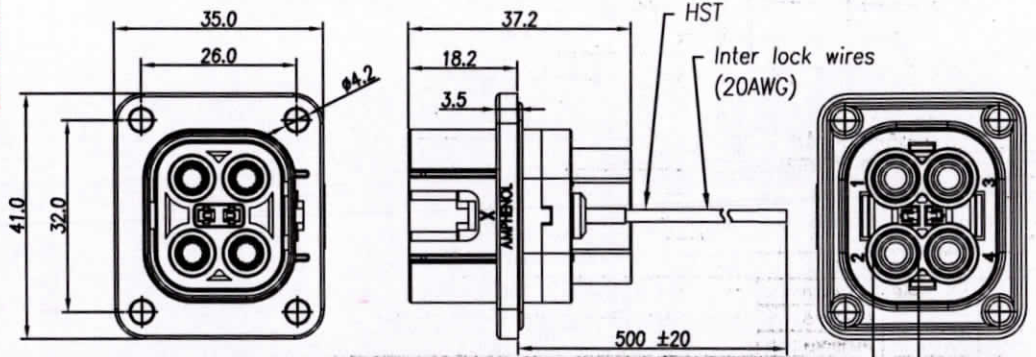
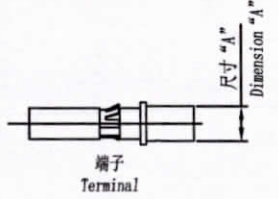
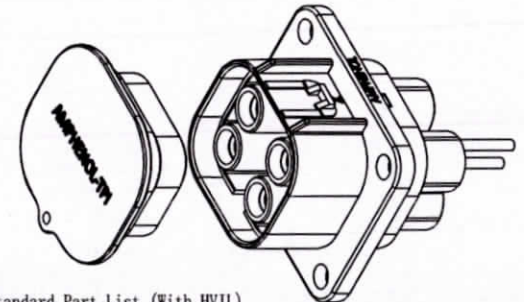
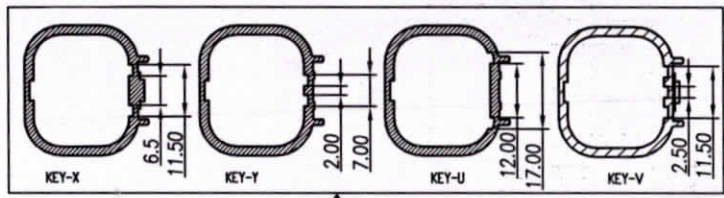

Standard Part List (With HVIL)

P/N	Model NO.	Dimension "A"	Cable size	Accepted cable OD
AC-HA002960	PL084X-4I-2.5	$\phi 3.70\text{mm}$	2.5mm <sup>2</sup>	$<\phi 7.5\text{mm}$
AC-HA002961	PL084Y-4I-2.5			
AC-HA002962	PL084U-4I-2.5	$\phi 4.57\text{mm}$	4mm <sup>2</sup>	$<\phi 7.5\text{mm}$
AC-HA010400	PL084V-4I-2.5			
AC-HA002963	PL084X-4I-4	$\phi 5.80\text{mm}$	6mm <sup>2</sup>	$<\phi 7.5\text{mm}$
AC-HA002964	PL084Y-4I-4			
AC-HA002965	PL084U-4I-4	$\phi 5.80\text{mm}$	6mm <sup>2</sup>	$<\phi 7.5\text{mm}$
AC-HA010401	PL084V-4I-4			
AC-HA002966	PL084X-4I-6	$\phi 5.80\text{mm}$	6mm <sup>2</sup>	$<\phi 7.5\text{mm}$
AC-HA002967	PL084Y-4I-6			
AC-HA002968	PL084U-4I-6	$\phi 5.80\text{mm}$	6mm <sup>2</sup>	$<\phi 7.5\text{mm}$
AC-HA010402	PL084V-4I-6			

Standard Part List (Without HVIL)

P/N	Model NO.	Dimension "A"	Cable size	Accepted cable OD
AC-HA002951	PL084X-4O-2.5	$\phi 3.70\text{mm}$	2.5mm <sup>2</sup>	$<\phi 7.5\text{mm}$
AC-HA002952	PL084Y-4O-2.5			
AC-HA002953	PL084U-4O-2.5	$\phi 4.57\text{mm}$	4mm <sup>2</sup>	$<\phi 7.5\text{mm}$
AC-HA010403	PL084V-4O-2.5			
AC-HA002954	PL084X-4O-4	$\phi 5.80\text{mm}$	6mm <sup>2</sup>	$<\phi 7.5\text{mm}$
AC-HA002955	PL084Y-4O-4			
AC-HA002956	PL084U-4O-4	$\phi 5.80\text{mm}$	6mm <sup>2</sup>	$<\phi 7.5\text{mm}$
AC-HA010404	PL084V-4O-4			
AC-HA002957	PL084X-4O-6	$\phi 5.80\text{mm}$	6mm <sup>2</sup>	$<\phi 7.5\text{mm}$
AC-HA002958	PL084Y-4O-6			
AC-HA002959	PL084U-4O-6	$\phi 5.80\text{mm}$	6mm <sup>2</sup>	$<\phi 7.5\text{mm}$
AC-HA010405	PL084V-4O-6			

- Notes:
- Surface Planeness of panel should be less than or equal to 0.2mm.
  - Surface Roughness of panel should be Ra 3.2 or better.

规格参数 (Spec.):

- 工作温度 Operating temperature: -40° C ~ +125° C.
- 带高压互锁 Electrical interlock (HVIL).
- 额定电流 Current rating (connector only): 2.5mm<sup>2</sup>: 25A, 4mm<sup>2</sup>: 35A, 6mm<sup>2</sup>: 45A; HVIL: 5A (20AWG).
- 额定电压 Operating voltage: Power: 1000 VDC; Signal: 60 VDC.
- 耐压 Dielectric withstanding voltage:
  - 与插头对接后, Pin与铁壳之间  
After mating, between pin and metal shell: 5000 VDC 60S 漏电流<5mA.
  - 与插头对接后, Pin与HVIL之间  
After mating, between pin and HVIL: 5000 VDC 60S 漏电流<5mA.
  - 与插头对接后, HVIL与铁壳之间  
After mating, between HVIL and metal shell: 500 VDC 60S 漏电流<5mA.
  - 与插头对接前, 两个HVIL端子之间耐压  
Before mating, between two HVIL terminals: 500 VDC 60S 漏电流<5mA.
- 防护等级 Protection Class: IP67 (水深1m, 浸泡0.5h) & IP2X.
- 阻燃等级 Flame Rating: 绝缘件 UL94-V0 密封件 UL94-HB.
- 电磁屏蔽 Shielding.
- 机械寿命 Mating cycle: 100 Min.
- 带自动二次锁扣 Automatic secondary lock.
- 接非屏蔽线 Accepts Unshielding Wire.
- 推荐法兰盘螺丝安装扭矩 Recommended Screw Assembly Torque on Flange: 1.6~2.4 Nm.

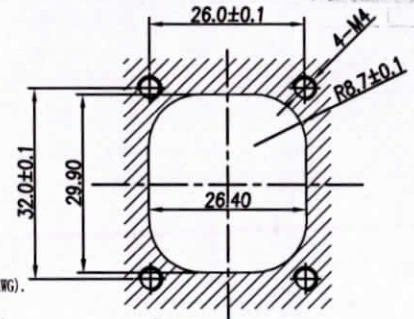

面板安装孔尺寸  
Panel Size

订购信息 Ordering Information

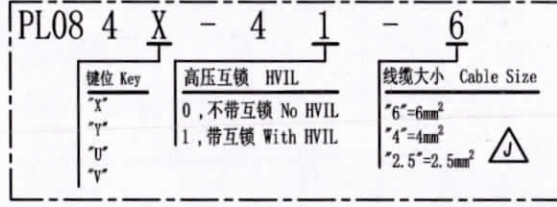

Amphenol Technical Products International Asia.

第三角投影 THIRD ANGLE PROJECTION	页码 SHEET	幅面 SIZE	版次 REV.	比例 SCALE	PART NAME <b>PartLok 4.0mm 4POS Rept Conn</b>
1 of 2	A3	M			
签名 SIGNATURE		日期 DATE		UNLESS OTHERWISE SPECIFIED	
制图 DRAWN		10/30/19		1) All dimensions are in metric (mm).	
审核 CHECKED		2017.10.30		2) Tolerances are as follows:	
批准 APPROVAL		2019.10.30		0 PL DEC ±1.00	
				1 PL DEC ±0.50	
				2 PL DEC ±0.30	
				Angle ±1°	PART NO. <b>PL084-40</b>
				CURR PART # <b>N/A</b>	CURR REV. <b>-</b>



THIS DRAWING IS SUPPLIED FOR INFORMATION ONLY. DESIGN FEATURES, SPECIFICATIONS AND PERFORMANCE DATA SHOWN HEREON ARE THE PROPERTY OF THE AMPHENOL CORPORATION. NO RIGHTS OF REPRODUCTION ARE IMPLIED. ALL DIMENSIONS ARE SUBJECT TO NORMAL MANUFACTURING VARIATIONS.

REVISIONS					
REV	ZONE	ECO	DESCRIPTION	DATE	BY APPR
K	---	---	Add specification description	08/22/18	ST JL
L	---	---	Redefine cable tolerances	09/28/18	ST JL
M	---	---	Cancel panel requirements	10/30/19	Steven JL

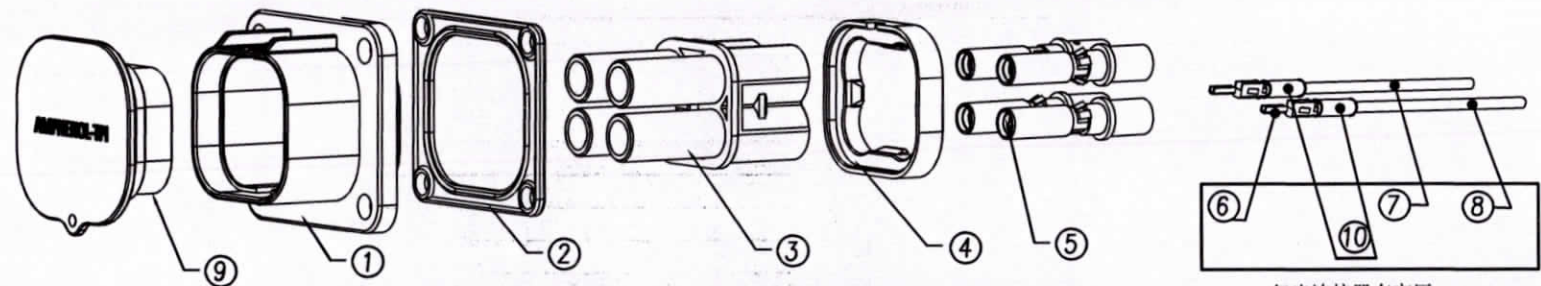

**Amphenol TPI**  
**2019-10-30**  
**REGISTERED COPY**

序号	名称	数量	材料	表面处理
10	HST H-2(Z) $\phi$ 2.0 BK	2		
9	PL3.6 4POS Rcpt Dust Cap	1	LDPE	
8	20AWG RE	A/R	ETFE	
7	20AWG BK	A/R	ETFE	
6	Mini-Fit Crimp Pin18-24AWG	2	铜合金	镀锡
5	PwrLok Soc 4mm	4	紫铜	镀锡3~5um
4	3.6mm, 4POS Cover for Rcpt	1	PA66	
3	3.6mm, 4POS Housing	1	PA66	
2	PwrLok Gasket 4POS 3.6mm	1	硅橡胶	
1	PwrLok Shell Rcpt	1	锌合金	镀镍5~8um

**MATERIALS LIST**

	Amphenol Technical Products International Asia.				
	第三角投影 THIRD ANGLE PROJECTION	页码 SHEET	幅面 SIZE	版次 REV.	比例 SCALE
签名 SIGNATURE	日期 DATE	UNLESS OTHERWISE SPECIFIED			图号 DRAWING NO.
制图 DRAWN	日期 DATE	1) All dimensions are in metric (mm). 2) Tolerances are as follows:			图号 DRAWING NO.
审核 CHECKED	日期 DATE	0 PL. DEC $\pm$ 1.00 1 PL. DEC $\pm$ 0.50 2 PL. DEC $\pm$ 0.20			图号 DRAWING NO.
批准 APPROVAL	日期 DATE	Angles $\pm$ 1°			图号 DRAWING NO.