

# Mini-Z™ Solid State Relay Design Board



## Overview

The Solid State Relay (SSR) Design Board, a complete and easy-to-use development platform for Zilog's series of Mini-Z stamp modules, is designed to provide engineers, students and enthusiasts a simple-to-use platform for developing prototypes and projects ranging from HVAC controls to animated control systems. Engineered to capitalize on the advanced functionality of Zilog's series of Mini-Z modules, the SSR Design Board exposes all of the Module's pins to add external functionality for even more creative projects.

The SSR Design Board is compatible with other vendor's modules, such as the Basic ATOM stamp and the Parallax BasicSTAMP. In essence, you can begin your project with what you already have and add a Mini-Z Module later when you are ready for its extra features. The SSR Design Board uses a USB-to-serial converter so that you no longer need to find a converter or a serial port. The SSR Design Board, shown in Figure 1, is designed to be operated by either a 9V battery or an external power supply.

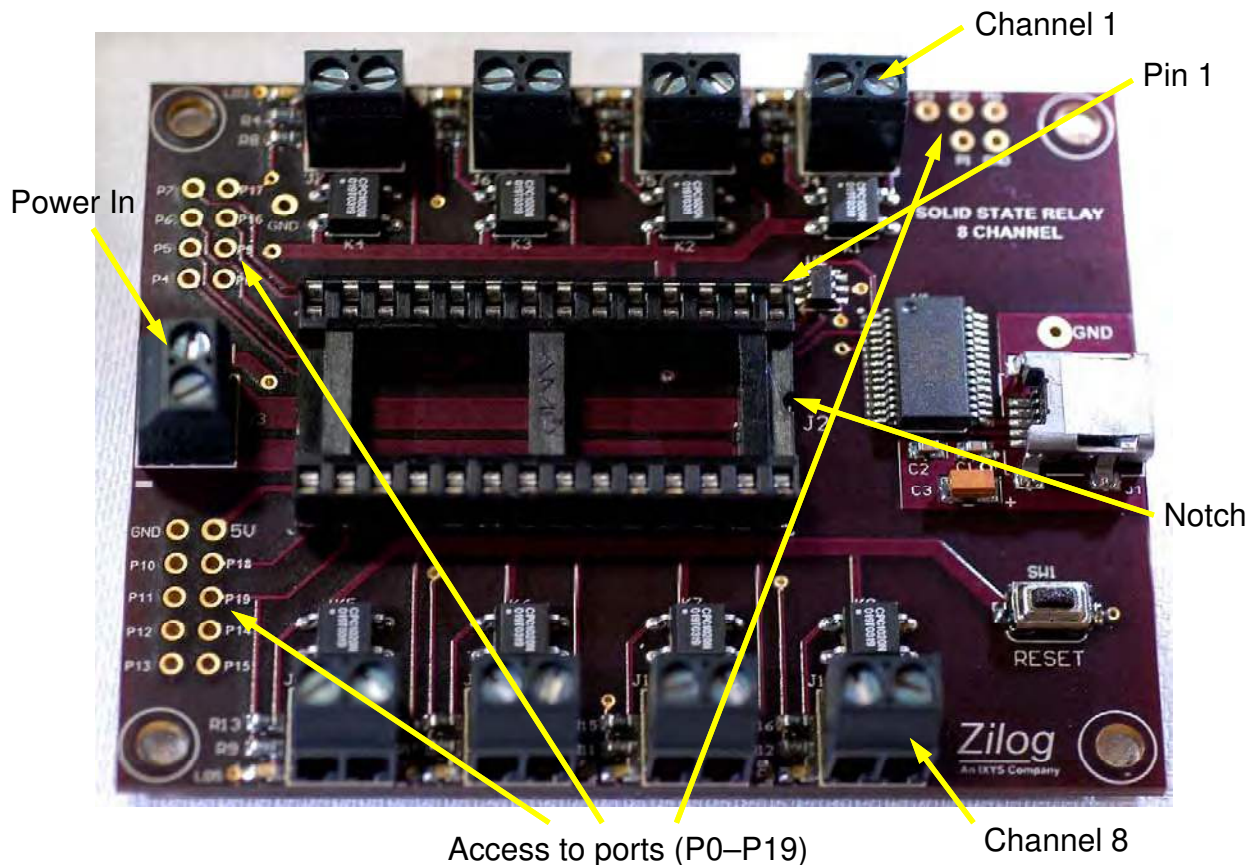

Figure 1. The Mini-Z Solid State Relay Design Board

---

## Mini-Z Solid State Relay Design Board Features

- Controls up to 8 optically isolated solid state relays to drive your devices
- USB serial communications: no more serial cables required
- Operated by battery or external power
- Compatible with the Parallax Basic STAMP programming boards, the BasicMicro ATOM Pro and Zilog's series of Mini-Z modules
- Each pin is accessible to add functionality through breadboards and cables to additional boards

## Potential Applications

The Mini-Z Solid State Relay Design Board can be used to develop a number of applications; the brief list below offers a few ideas.

- 12/24 Volt fans
- 12/24 Volt HVAC control; build your own multistage furnace thermostat
- Control 12/24 Volt architectural lighting
- Animated control system: up to 8 individual props
- Audio device control
- Pneumatic controls

## Port to SSR Channel Mapping

Each channel on the Mini-Z Solid State Relay Design Board maps to a port on the Mini-Z Modules, as shown in Table 1.

**Table 1. Port to SSR Channel Map**

SSR Channel	Port
CH1	P9
CH2	P8
CH3	P16
CH4	P17
CH5	P19
CH6	P18
CH7	P5
CH8	P4

---

## Socket Pin-Out

Socket Pin-Out to connection point mapping. See Table 2.

**Table 2. Socket Pin-Out**

Socket Pin	Pin Name
1	S <sub>OUT</sub>
2	S <sub>IN</sub>
3	DTR
4	VSS
5	PO
6	P1
7	P2
8	P3
9	P4
10	P5
11	P6
12	P7
13	P16
14	P17
15	P18
16	P19
17	P8
18	P9
19	P10
20	P11
21	P12
22	P13
23	P14
24	P15
25	V <sub>CC</sub> I/O
26	Reset
27	V <sub>SS</sub>
28	V <sub>IN</sub>

## Electrical Specifications

Stresses greater than those listed in Table 3 may cause permanent damage to the device. These ratings are stress ratings only. Operation of the device at any condition outside those indicated in the operational sections of these specifications is not implied. Exposure to absolute maximum rating conditions for extended periods affects device reliability. For improved reliability, unused inputs must be tied to one of the supply voltages ( $V_{DD}$  or  $V_{SS}$ ).

Table 3 describes the electrical characteristics of the Mini-Z Solid State Relay Design Board and reflects all available data as a result of testing prior to qualification and characterization. As such, the data presented in Table 3 is subject to change.

**Table 3. Electrical Specifications for the Mini-Z Solid State Relay Design Board**

Parameter	Min	Max	Units	Notes
$V_{IN}$ range		20	Volts	Module-dependent.
Max voltage range, all other pins	-0.3	5.5	Volts	I/O pins and Reset.
Max current for I/O pin connection points	-25	25	Milliamps (mA)	
Max $V_{IN}$ current		1	Amps	
Ambient temperature	-40	105	Degrees Celsius	
Storage temperature	-65	150	Degrees Celsius	

Table 4 describes the electrical characteristics of the Mini-Z Solid State Relay Design Board under load conditions. For more information, please see the [CPC1020N Single-Pole, Normally Open 4-Lead SOP OptoMOS Relay Data Sheet \(CPC1020N\)](#), available from the clare.com website.

**Table 4. Electrical Characteristics for the Mini-Z Solid State Relay Design Board**

Parameter	Condition	Symbol	Min	Typ	Max	Units
Max Voltage		$V_{MAX}$			30	V
Load Current		$I_L$			1.2	ADC
On-Resistance	$I_L = 1A$	$R_{ON}$		0.116	.25	Ohms
Off-State Leakage	$V_L = 30V$	$I_{LEAK}$			1	$\mu A$
Switching Speeds						
Turn-On	$V_L = 10V$	$t_{ON}$		0.48	3	ms
Turn-Off		$t_{OFF}$		0.65	3	
Output Capacitance	$V_L = 30V, f = 1MHz$	$C_{OUT}$		70		pF

---

Table 5 describes the electrical characteristics of the Mini-Z Solid State Relay Design Board's terminal blocks.

**Table 5. Terminal Block Specifications**

Rated Voltage	150 Volt
Rated Current	6 Amps
Wire Size	AWG 28-16
Test Voltage	2.0K volts
Rated Torque/Screw Size	0.4 Nm/M2
Wire:	
Max rated cross section:	
Solid Wire	1.5mm
Stranded Wire	1.5mm
Stranded wire with Ferrules	.75mm
Stripped Length	5.5mm

## Packaging

Figure 2 displays an assembly diagram of the Mini-Z Solid State Relay Design Board.

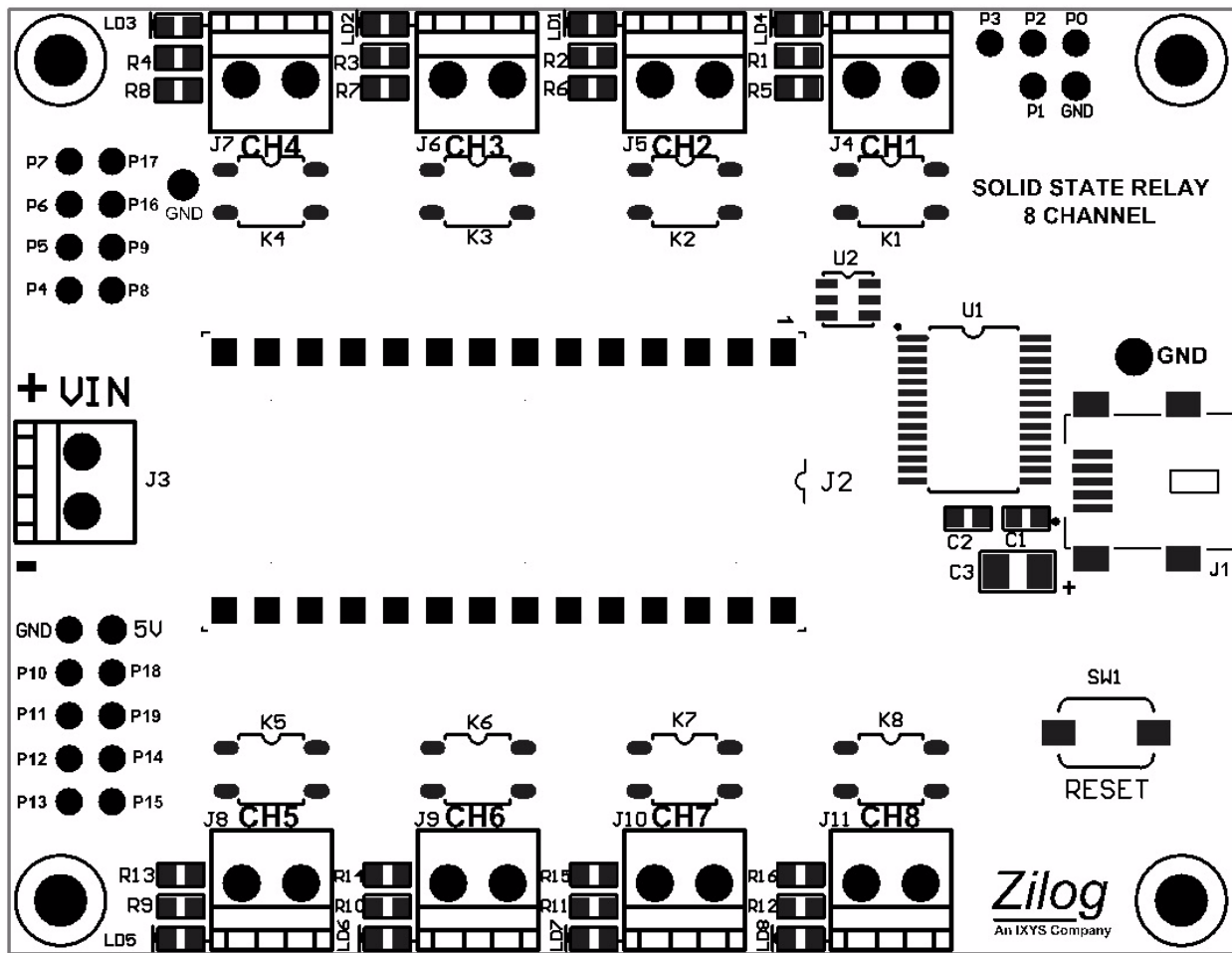

Figure 2. Mini-Z Solid State Relay Design Board Assembly Diagram

## Mechanical Profile

Figure 3 displays the top- and side-view dimensions of the Mini-Z Solid State Relay Design Board.

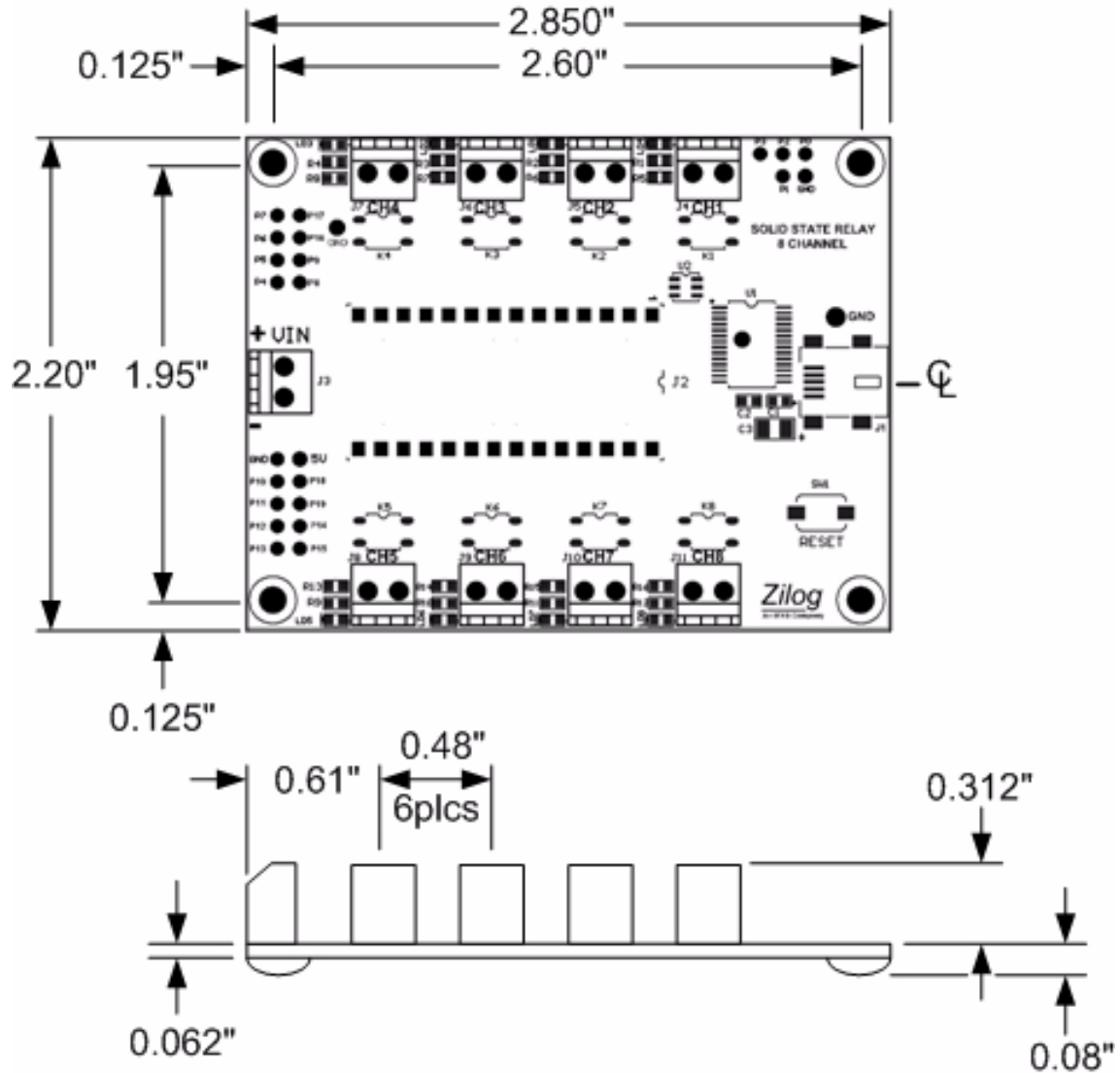

Figure 3. Mini-Z Solid State Relay Design Board Dimensions

## Ordering Information

The products associated with the Mini-Z Solid State Relay Design Board are available individually or as a kit and can be purchased from the Zilog Store – simply click the Store Product IDs listed in Table 6.

**Table 6. Mini-Z Solid State Relay Design Board Ordering Information**

Part Number	Description	Store Product ID
Z16SSR00100DBG	Mini-Z Solid State Relay Design Board	<a href="#">RD10001</a>
Z16F2800100MODG	Mini-Z ZNEO 28-Pin Module	<a href="#">RD10002</a>
Z16F28WF100MODG	Mini-Z WLAN 28-Pin Module	<a href="#">RD10003</a>
Z16SSR00100KITG	Mini-Z ZNEO SSR Kit*	<a href="#">RD10004</a>
Z16F28WF100KITG	Mini-Z WLAN SSR Kit	<a href="#">RD10006</a>

Note: \*The Mini-Z ZNEO SSR Kit ships with a 9V battery connector.

## Kit Contents

The Mini-Z ZNEO SSR Kit contains the following elements:

- Mini-Z ZNEO 28-Pin Module
- Mini-Z Solid State Relay Design Board
- USB Smart Cable
- Mini-Z to standard debug adapter
- USB cable (A male to Mini-B male)
- DIP Package Extractor

The Mini-Z WLAN 28-Pin SSR Kit contains the following elements:

- Mini-Z WLAN 28-Pin Module
- Mini-Z Solid State Relay Design Board
- USB Smart Cable
- Mini-Z to standard debug adapter
- USB cable (A male to Mini-B male)
- DIP Package Extractor



---

## Related Documentation

The documents associated with the Mini-Z Solid State Relay Design Board are listed in Table 7. Each of these documents can be obtained from the Zilog website (except where noted) by clicking the link associated with its Document Number.

**Table 7. ZAURA RF Wireless Module Documentation**

<b>Document Number</b>	<b>Description</b>
<a href="#">RD0007</a>	This Mini-Z Solid State Relay Design Board Reference Design document
<a href="#">RD0006</a>	Mini-Z ZNEO 28-Pin Module Reference Design document
<a href="#">RD0006-SC01</a>	Mini-Z Library
<a href="#">RM0061</a>	Mini-Z Shell and Flash Loader Reference Manual
<a href="#">PS0220</a>	ZNEO Z16F Series Product Specification
<a href="#">UM0188</a>	ZNEO CPU Core User Manual
<a href="#">UM0181</a>	USB Smart Cable User Manual
<a href="#">Clare website</a>	CPC1020N Single-Pole, Normally Open 4-Lead SOP OptoMOS Relay Data Sheet

# Schematic Diagram

Figure 4 shows a schematic diagram of the Mini-Z Solid State Relay Design Board.

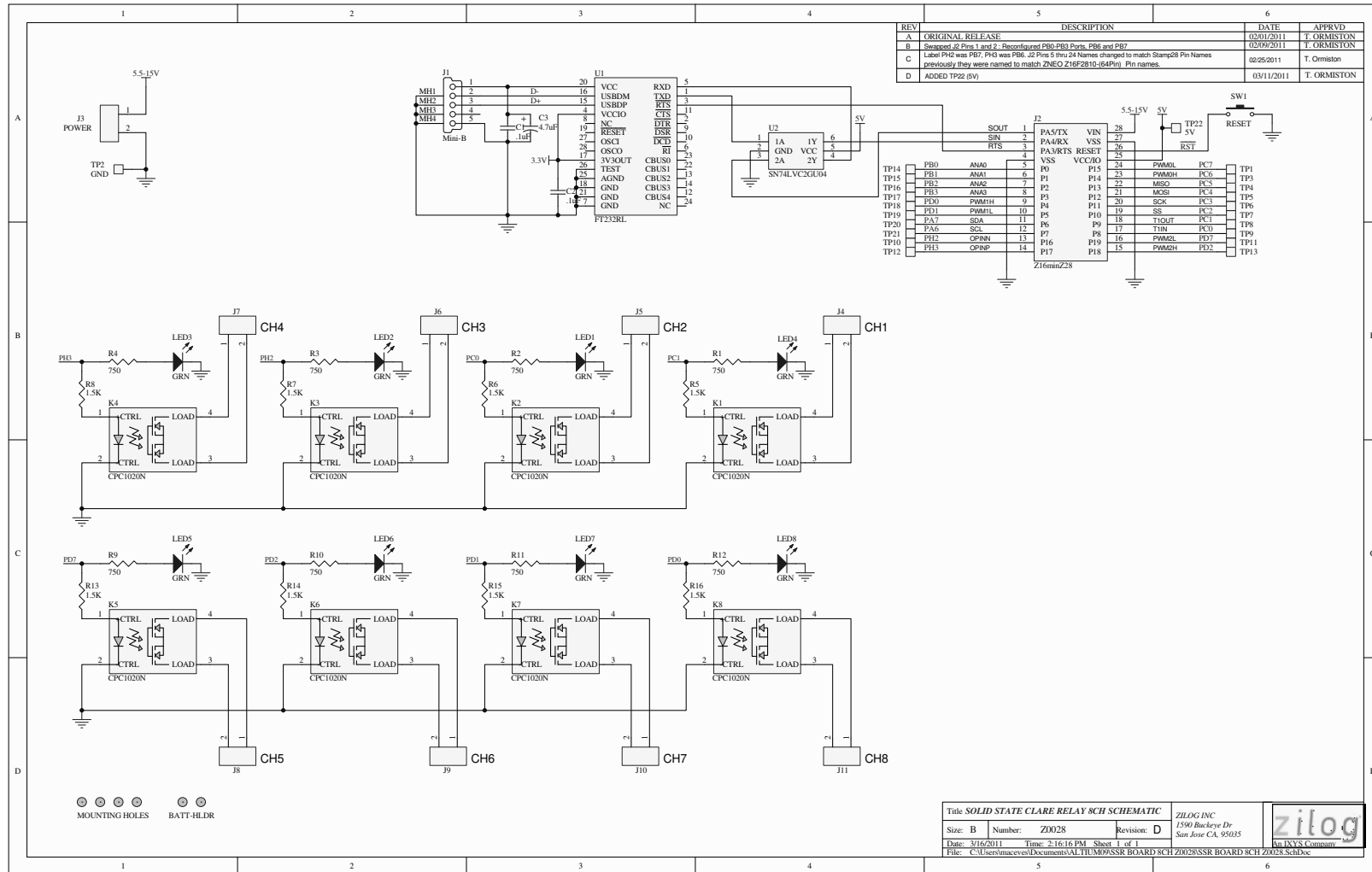

Figure 4. Mini-Z Solid State Relay Design Board Schematics

---

## Customer Support

To learn more about this product, find additional documentation, get your technical questions answered or report issues, please contact [esales@zilog.com](mailto:esales@zilog.com).



**Warning:** DO NOT USE THIS PRODUCT IN LIFE SUPPORT SYSTEMS.

---

### LIFE SUPPORT POLICY

ZILOG'S PRODUCTS ARE NOT AUTHORIZED FOR USE AS CRITICAL COMPONENTS IN LIFE SUPPORT DEVICES OR SYSTEMS WITHOUT THE EXPRESS PRIOR WRITTEN APPROVAL OF THE PRESIDENT AND GENERAL COUNSEL OF ZILOG CORPORATION.

### As used herein

Life support devices or systems are devices which (a) are intended for surgical implant into the body, or (b) support or sustain life and whose failure to perform when properly used in accordance with instructions for use provided in the labeling can be reasonably expected to result in a significant injury to the user. A critical component is any component in a life support device or system whose failure to perform can be reasonably expected to cause the failure of the life support device or system or to affect its safety or effectiveness.

### Document Disclaimer

©2014 Zilog, Inc. All rights reserved. Information in this publication concerning the devices, applications, or technology described is intended to suggest possible uses and may be superseded. ZILOG, INC. DOES NOT ASSUME LIABILITY FOR OR PROVIDE A REPRESENTATION OF ACCURACY OF THE INFORMATION, DEVICES, OR TECHNOLOGY DESCRIBED IN THIS DOCUMENT. ZILOG ALSO DOES NOT ASSUME LIABILITY FOR INTELLECTUAL PROPERTY INFRINGEMENT RELATED IN ANY MANNER TO USE OF INFORMATION, DEVICES, OR TECHNOLOGY DESCRIBED HEREIN OR OTHERWISE. The information contained within this document has been verified according to the general principles of electrical and mechanical engineering.

ZNEO and Mini-Z are trademarks or registered trademarks of Zilog, Inc. All other product or service names are the property of their respective owners. Zilog and Clare are divisions of IXYS Corporation.