

PLD E 409 W 350 - LED enclosure light



1319569

<https://www.phoenixcontact.com/us/products/1319569>

Please be informed that the data shown in this PDF document is generated from our online catalog. Please find the complete data in the user documentation. Our general terms of use for downloads are valid.



LED enclosure light, 24 V AC/DC ... 240 V AC/DC, length: 350 mm, degree of protection: IP20, can be swiveled ($\pm 90^\circ$ swivel range), including mounting accessories

Product description

The LED light is designed to illuminate the interior of control cabinets. The prismatic integrated into the light cover ensures optimum illumination of the control cabinet. You can use magnets or screws to affix the light holder. The light can swivel in the holder. Connect the supply voltage to the light via Push-in connection. You do not require special connectors for this. You can connect several lights in succession. A button is used to switch the light on and off.

Your advantages

- Series connection reduces cabling effort for control cabinets arranged in series
- Optimum lighting of the control cabinet, thanks to integrated prismatic and capacity to swivel
- Swiveling enables optimum adjustment to the relevant control cabinet depth
- LED service life of 50,000 h (L70 value) prevents bulb replacement

Commercial data

Item number	1319569
Packing unit	1 pc
Minimum order quantity	1 pc
Sales key	DR08
Product key	DRL232
GTIN	4063151602888
Weight per piece (including packing)	232.5 g
Weight per piece (excluding packing)	150 g
Customs tariff number	94054231
Country of origin	DE

PLD E 409 W 350 - LED enclosure light



1319569

<https://www.phoenixcontact.com/us/products/1319569>

Technical data

Product properties

Product type	Light
Mounting position	any
Application	Control cabinet
Socket	none

Electrical properties

Supply: Module electronics

Connection method	Push-in connection
Number of positions	2
Supply voltage range	24 V AC/DC ... 240 V AC/DC $\pm 5\%$ (50/60 Hz (AC))
Power consumption	6 W

Connection data

Connection method	Push-in connection
Conductor cross section, rigid	0.13 mm ² ... 1.5 mm ²
Conductor cross section, flexible	0.13 mm ² ... 1.5 mm ²
Conductor cross section AWG	24 ... 16
Conductor cross section, flexible, with ferrule, with plastic sleeve	0.5 mm ² ... 0.75 mm ² (DIN 46228-4)
Conductor cross section flexible, with ferrule without plastic sleeve	0.5 mm ² ... 1.5 mm ² (DIN 46228-1)
Stripping length	10 mm

Signaling

Light properties

Source of light type	LED
Number of LEDs	18
Service life, lighting appliance	50000 h
Color temperature	5000 K
Color rendering index	85
Luminous flux	700 lm (Net luminous flux)
Illumination	max. 1200 lx (50 cm distance)
	max. 450 lx (Distance of 1 m)
Ordinance	Delegated Regulation (EU) 2019/2015
Energy efficiency class	D (1 light source)
Note	This product contains an energy efficiency class D light source.

Dimensions

PLD E 409 W 350 - LED enclosure light



1319569

<https://www.phoenixcontact.com/us/products/1319569>

Dimensional drawing	
Width	39 mm
Height	45 mm
Length	350 mm

Material specifications

Color	traffic grey A RAL 7042
-------	-------------------------

Environmental and real-life conditions

Ambient conditions

Ambient temperature (operation)	-20 °C ... 60 °C
Degree of protection	IP20
Ambient temperature (storage/transport)	-40 °C ... 85 °C
Permissible humidity (operation)	5 % ... 90 %
Permissible humidity (storage/transport)	5 % ... 90 %

Standards and regulations

Protection class	II
------------------	----

Mounting

Mounting type	Screw/magnet mounting
Mounting position	any

PLD E 409 W 350 - LED enclosure light



1319569

<https://www.phoenixcontact.com/us/products/1319569>

Drawings

Schematic diagram

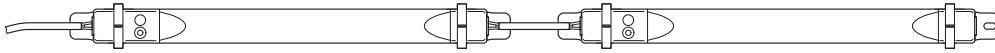

Series connection of two lights

Schematic diagram

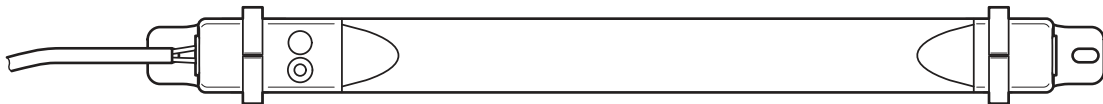

Connection of a light

Dimensional drawing

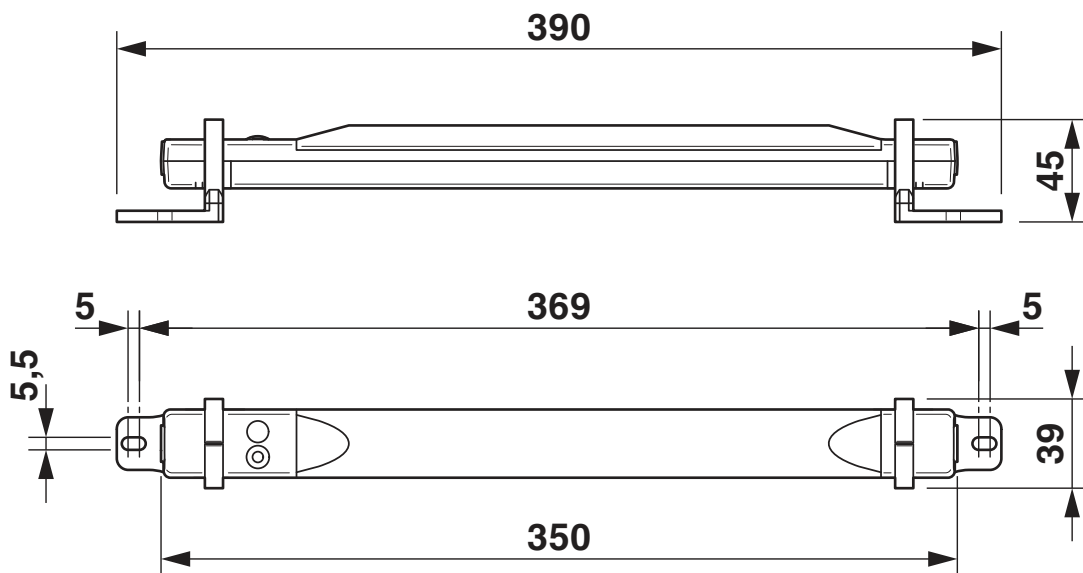

Dimensions (in mm)

Block diagram

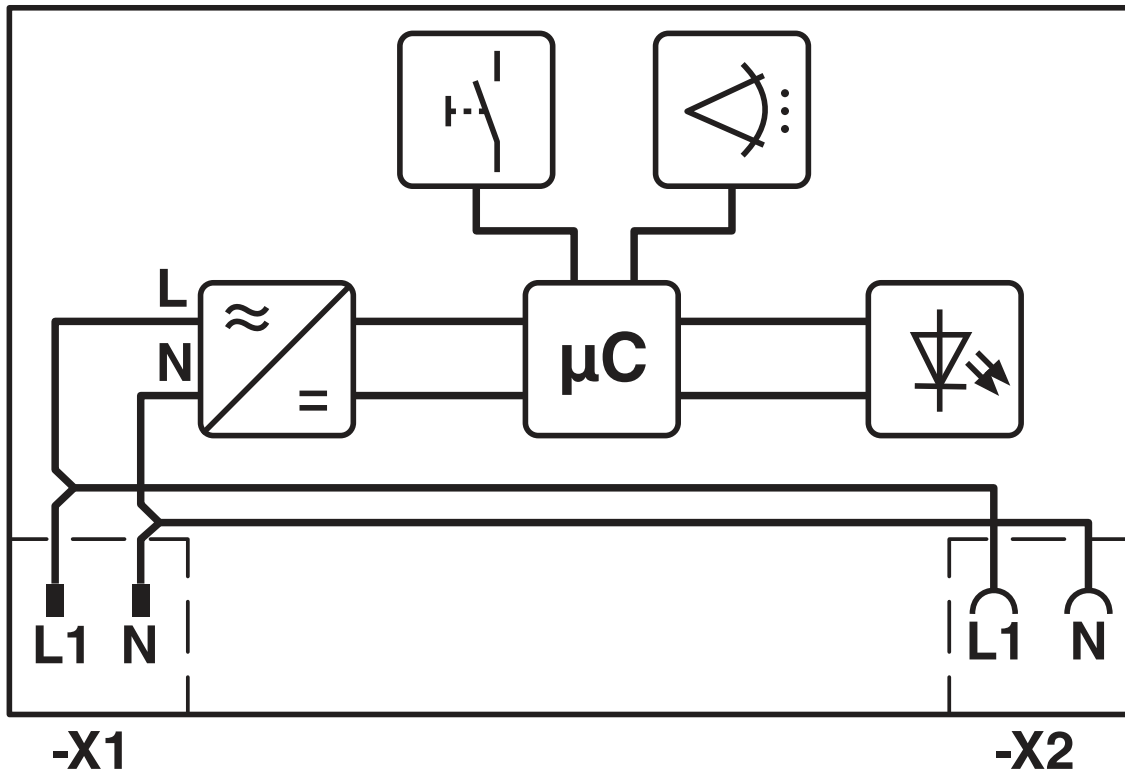

Internal wiring (motion detector only with PLD E 409 W 350 MS)

PLD E 409 W 350 - LED enclosure light



1319569

<https://www.phoenixcontact.com/us/products/1319569>

Approvals

To download certificates, visit the product detail page: <https://www.phoenixcontact.com/us/products/1319569>



cUL Recognized
Approval ID: FILE E 255026



UL Recognized
Approval ID: FILE E 255026

cULus Recognized

PLD E 409 W 350 - LED enclosure light



1319569

<https://www.phoenixcontact.com/us/products/1319569>

Classifications

ECLASS

ECLASS-11.0	27182808
ECLASS-12.0	27182808
ECLASS-13.0	27182808

ETIM

ETIM 8.0	EC000321
----------	----------

UNSPSC

UNSPSC 21.0	32151500
-------------	----------

PLD E 409 W 350 - LED enclosure light



1319569

<https://www.phoenixcontact.com/us/products/1319569>

Environmental product compliance

China RoHS	Environmentally friendly use period: unlimited = EFUP-e
	No hazardous substances above threshold values

PLD E 409 W 350 - LED enclosure light



1319569

<https://www.phoenixcontact.com/us/products/1319569>

Accessories

PLD E 400-DS-3,0/0,6 - Door position switch

1318672

<https://www.phoenixcontact.com/us/products/1318672>



Door position switch with 3 m cable with open cable end and 0.6 m cable with open cable end, including mounting accessories

PLD E 409 CLP/M - Holder

1531603

<https://www.phoenixcontact.com/us/products/1531603>

Replacement magnetic holder (1 pair) for PLD E 409 W 350 and PLD E 409 W 350 MS LED enclosure lights



Phoenix Contact 2023 © - all rights reserved

<https://www.phoenixcontact.com>

Phoenix Contact USA
586 Fulling Mill Road
Middletown, PA 17057, United States
(+717) 944-1300
info@phoenixcon.com