

Intematix ChromaLit™ 360

Remote Phosphor Light Source: Ellipse, Candle, Dome

ChromaLit 360 light sources enable brighter, more energy efficient LED bulbs and lighting fixtures by providing wide angle lighting distribution, improved light quality, and greater design freedom. These remote phosphor light sources from Intematix provide highly uniform light distribution and are offered in a variety of lumen levels for applications in indoor and outdoor general lighting, decorative and retrofit light bulb designs.

Features & Benefits

- High light quality with choice of CCT & CRI options
- Uniform, glare-free light that is diffuse and offers soft shadows
- Reduces costs with a smaller heatsink thereby lowering supply chain costs
- Streamlined supply and production of LED lighting systems
- Up to 30% higher system efficacy compared to conventional LED lighting designs

Applications & Uses

- LED retrofit light bulbs
- Portable consumer lighting
- Down lights
- Wall sconces
- Pendants
- Chandelier and other decorative applications
- Appliances



TABLE OF CONTENTS

Product Nomenclature	3
Minor Product Change Policy	3
Optical Characteristics	4
Color Binning Information	4
Relative Spectral Power Distribution	5
Intensity Distribution Diagrams	6
Performance Characteristics Over Wavelength	8
Relative Conversion Efficacy Over Temperature	8
Absolute Maximum and Minimum Ratings	10
Mechanical Characteristics	10
Reliability and Environmental Ratings	14
Handling Considerations	14
Company Information	14

Product Nomenclature

ChromaLit 360 products are identified by the following product nomenclature:

Product order code

CL-ABC-DEFGH-IJ

Where:

A - Designates the first digit of CRI

8 = 80 CRI minimum

BC - Designates the first two digits of CCT

30 = 3000K, 40 = 4000K, etc.

DEF - Designates shape

CAN = candle, ELP = ellipse, DOM = dome

GH - Product identification number

IJ - Designates the standard polycarbonate material used

Example:

CL-830-CAN15-PC represents ChromaLit 80CRI, 3000K CCT, Candle 15, polycarbonate

Minor Product Change Policy

The rigorous qualification testing of ChromaLit products ensures product performance. Slight cosmetic changes which do not affect the form fit or function of the product may occur as Intematix continues product optimization.

Optical and Performance Characteristics¹

Color Designation	CCT ² (K)	Color Consistency ³ MacAdam Ellipses	Min CRI ⁴	Minimum Conversion Efficacy ⁵ (Lm/W _{rad}) at 25°C	Typical Conversion Efficacy ⁵ (Lm/W _{rad}) at 25°C
CL-827	2700	3-step	80	170	180
CL-927	2700	3-step	90	155	165
CL-830	3000	3-step	80	185	200
CL-930	3000	3-step	90	160	170
CL-835	3500	3-step	80	195	205
CL-840	4000	3-step	80	200	210
CL-750	5000	4-step	70	215	225

Notes

1. Performance based on reference design. Please refer to application note for details on reference design. Intematix maintains a tolerance of $\pm 7\%$ of luminous flux and radiant watt measurements. Intematix maintains a tolerance of 0.5 MacAdam Ellipses on color consistency measurements.
2. Correlated Color Temperature
3. Color Consistency is dependent on the AVERAGE dominant wavelength of blue LED source. ChromaLit maintains color consistency within a 3-step MacAdam Ellipse given a uniform blue LED source with a constant average wavelength. 2.5nm (± 1.25 nm) of average blue LED wavelength variation will provide 4-step MacAdam Ellipses of color consistency. 5nm (± 2.5 nm) of average blue LED wavelength variation will provide 5-step MacAdam Ellipses of color consistency. Values are approximate, please refer to bin diagram on the following page for exact bin definition.
4. Minimum Color Rendering Index rating is based on reference design using blue LEDs with average dominant wavelength of 455nm.
5. Conversion Efficacy is the luminous flux (white light) output per radiant watt of blue light input to ChromaLit. W_{rad} is the radiometric power measured in watts. Conversion efficacy is rated based on reference operation and dominant blue LED wavelength of 455nm (peak wavelength of 450nm).

Color Binning Diagram

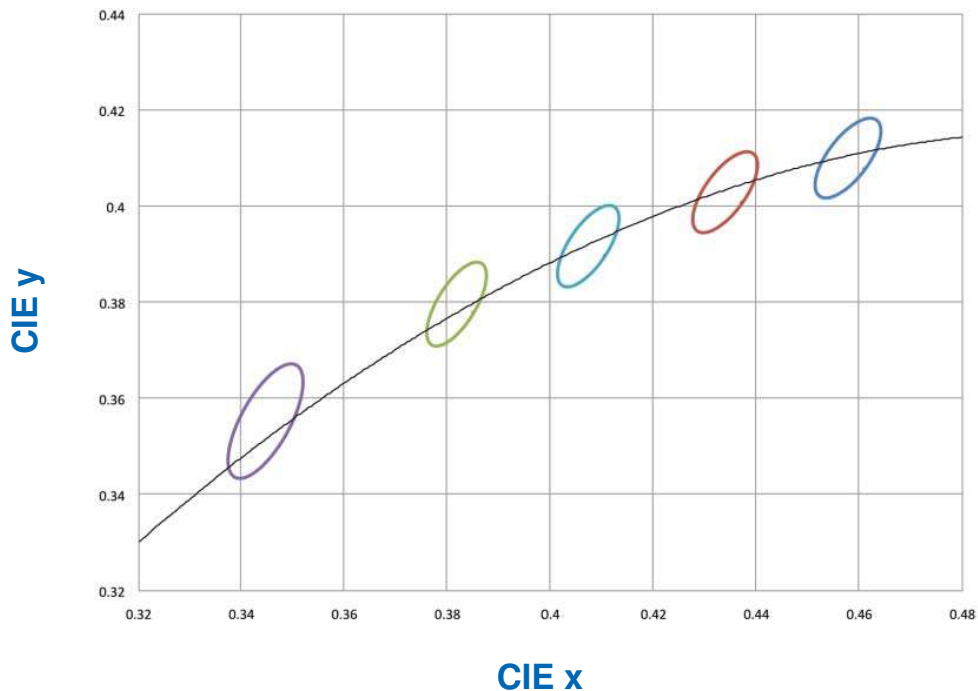

Color Bin Center Points

CCT (K)	x	y
2700	0.4578	0.4101
3000	0.4338	0.4030
3500	0.4073	0.3917
4000	0.3818	0.3797
5000	0.3447	0.3553

Relative Spectral Power Distribution

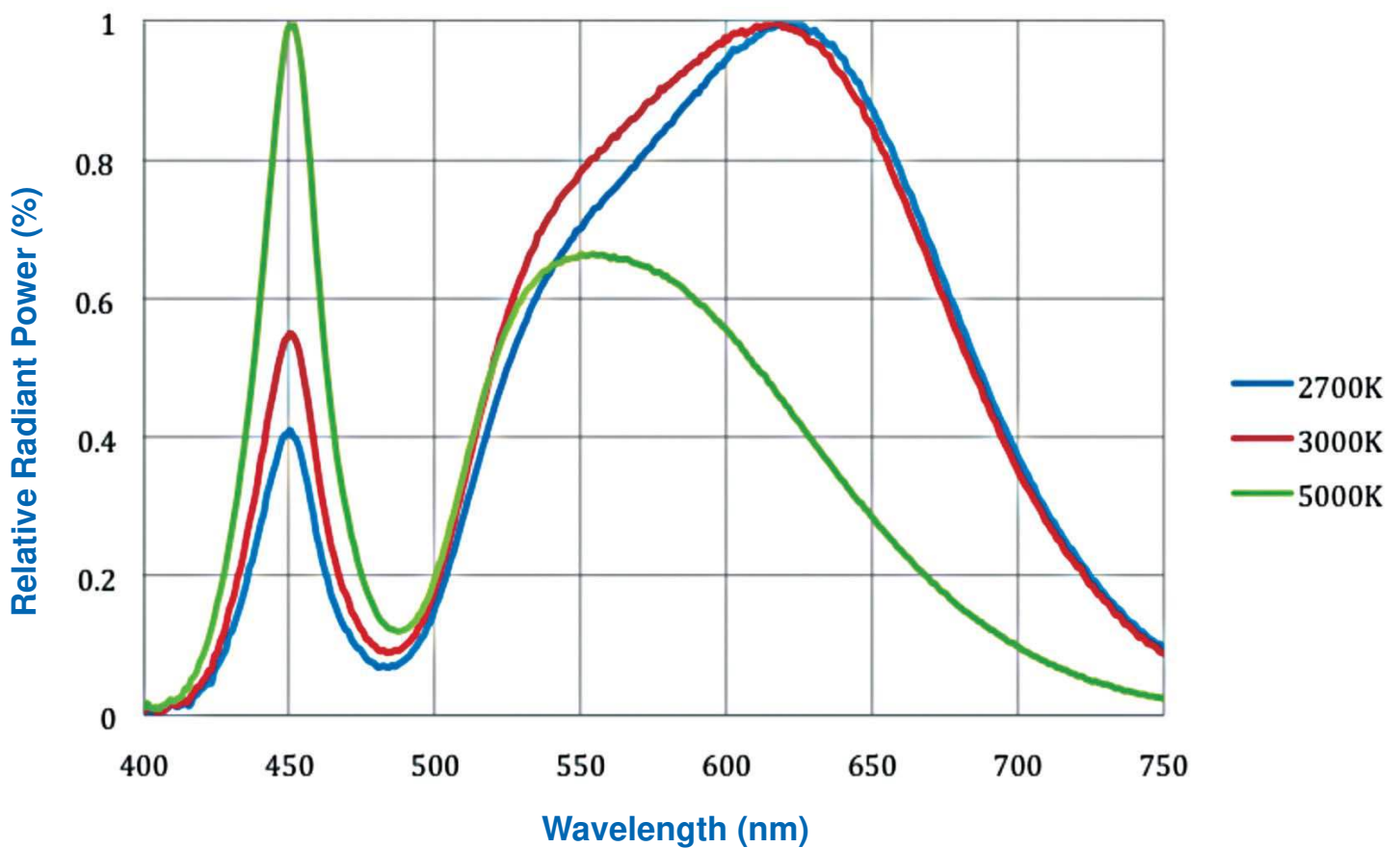

Intensity Distribution - Ellipse

Luminous Intensity Distribution Diagram¹

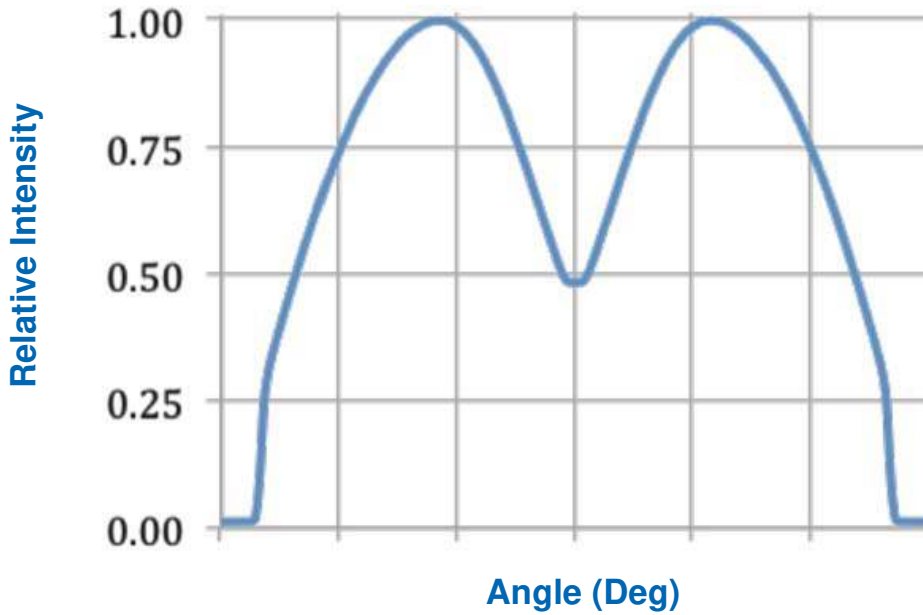

Beam Angle (Full Angle)	280°
Maximum Intensity Angle (Half Angle)	75°

Luminous Intensity Polar Diagram

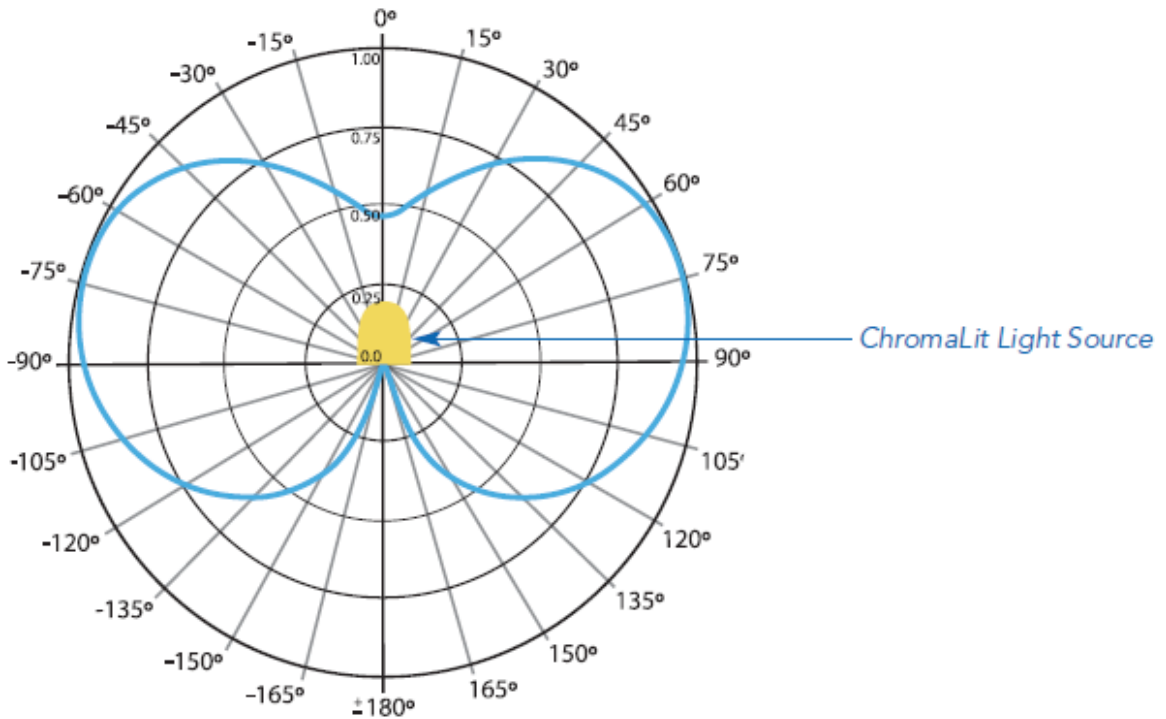

¹ Intensity distribution pattern is characterized using CL-750-ELP60-PC products.

Intensity Distribution - Candle

Luminous Intensity Distribution Diagram¹

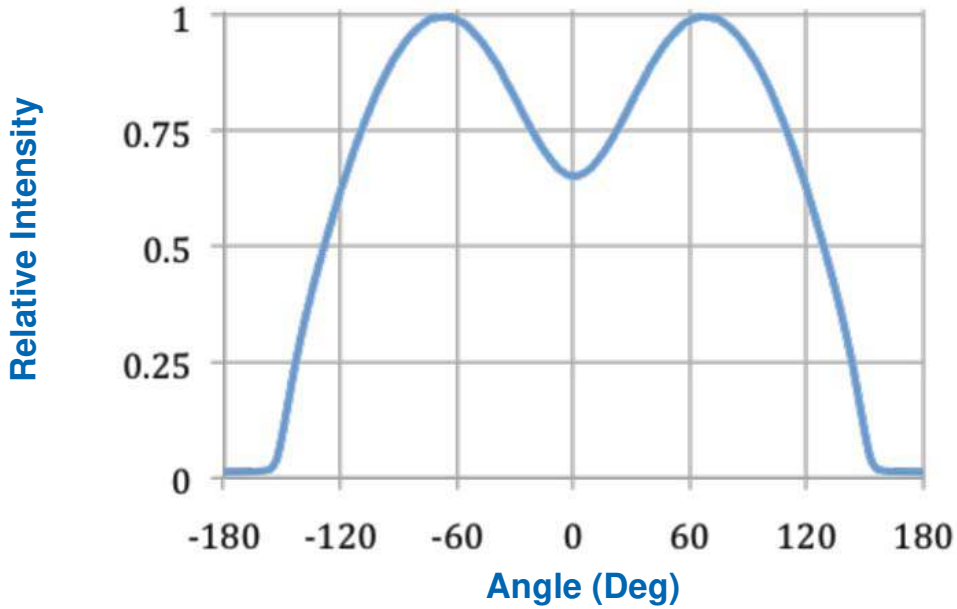

Beam Angle (Full Angle)	255°
Maximum Intensity Angle (Half Angle)	70°

Luminous Intensity Polar Diagram

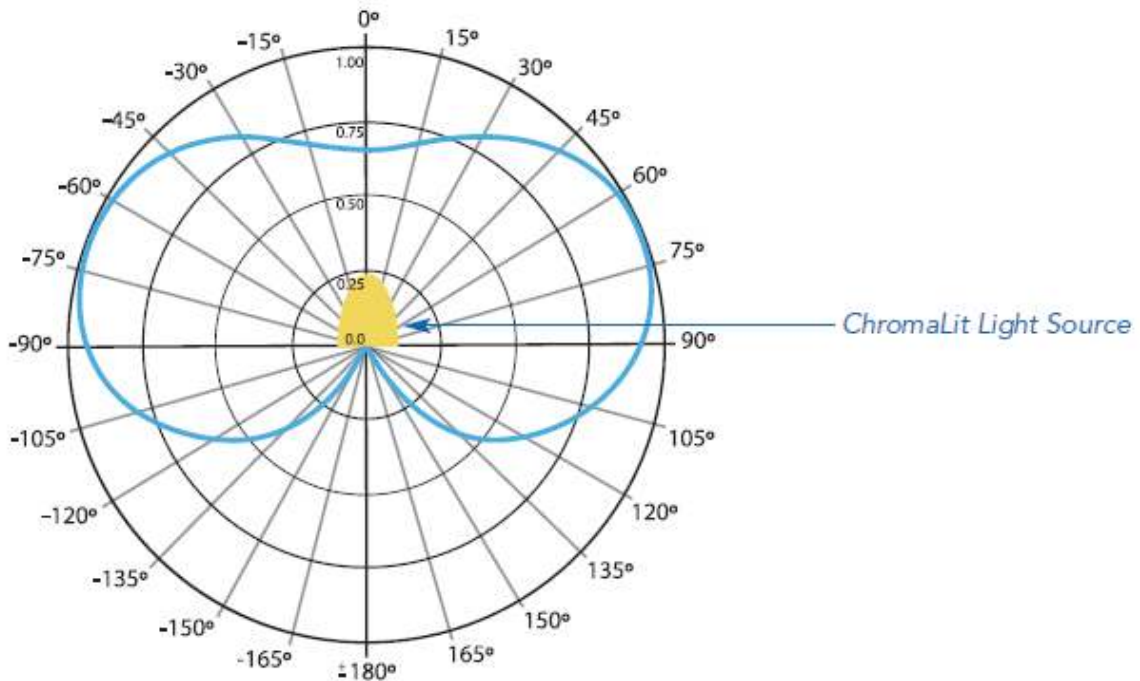

¹ Intensity distribution pattern is characterized using CL-750-CAN40-PC products.

Intensity Distribution - Dome

Luminous Intensity Distribution Diagram

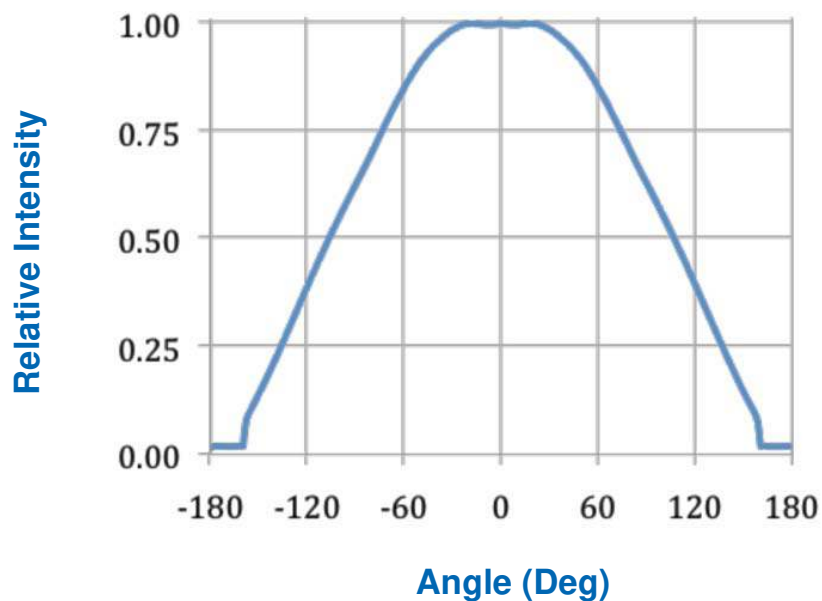

Beam Angle (Full Angle)	215°
Maximum Intensity Angle (Half Angle)	0°

Luminous Intensity Polar Diagram

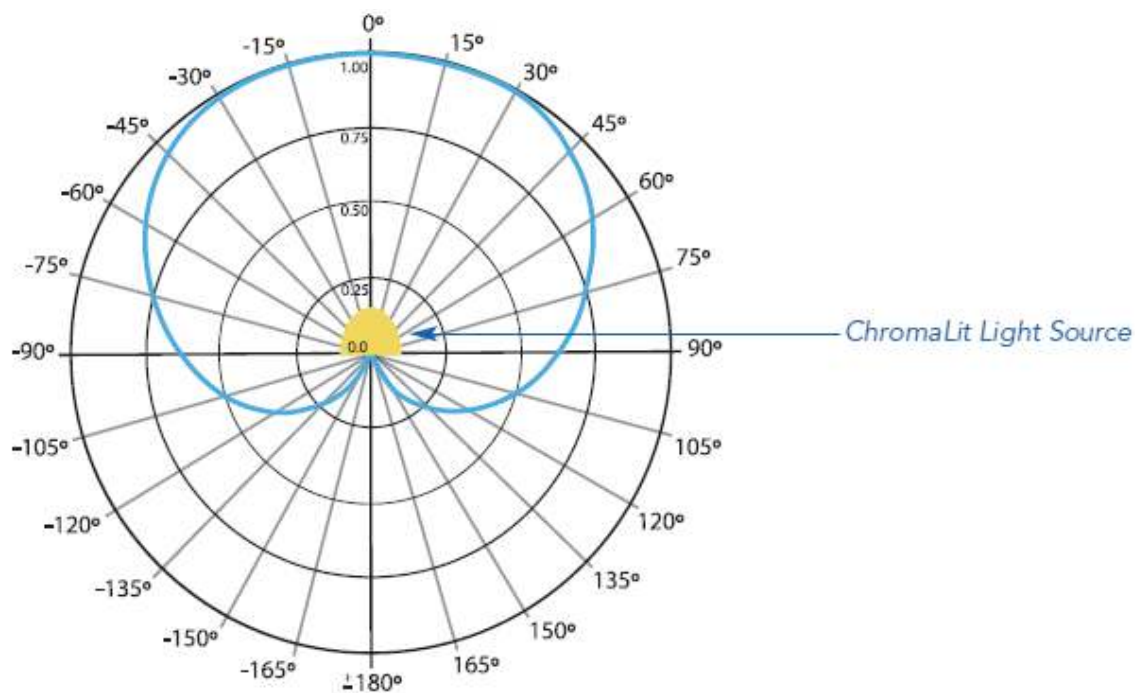

¹ Intensity distribution pattern is characterized using CL-750-DOM60-PC products.

Performance Characteristics over Wavelength

Relative Conversion Efficacy over Wavelength¹

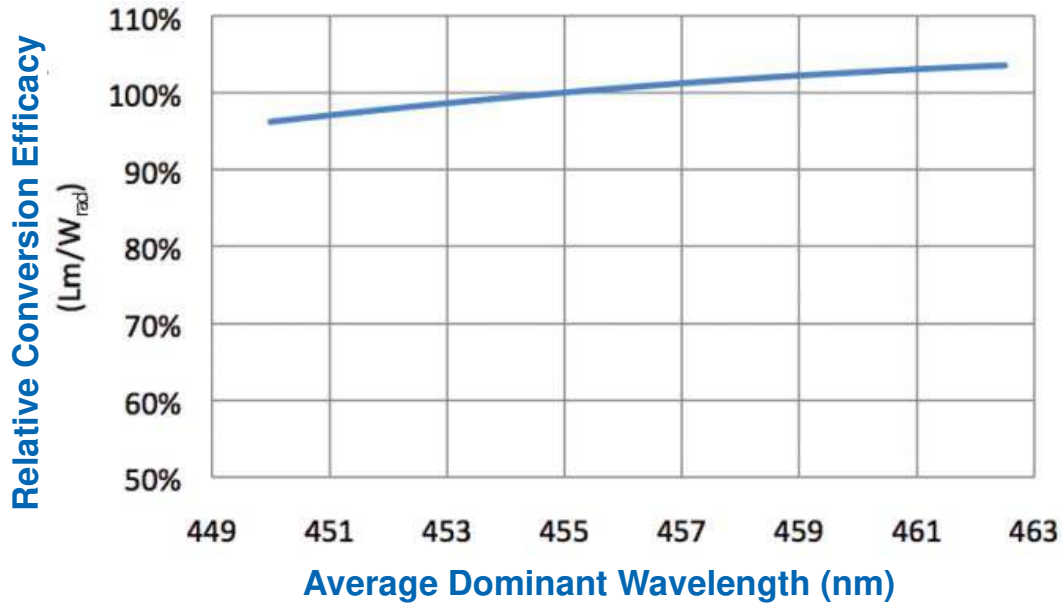

¹ Relative conversion efficacy does not reflect performance of blue LED over dominant wavelength.

Performance Characteristics over Temperature

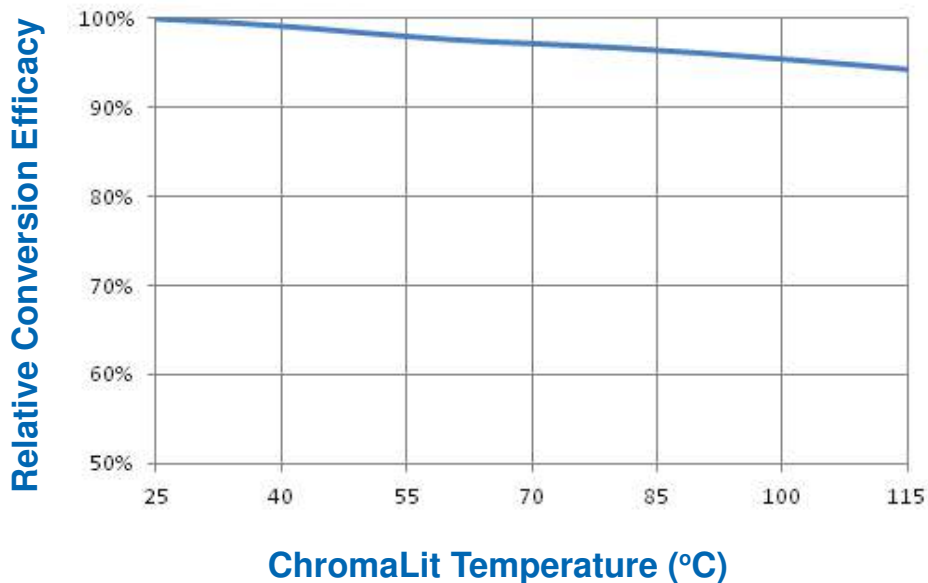

Relative CIE Chromaticity Shift over Wavelength

	Average Dominant Wavelength				
	450nm	452.2nm	455nm	457.5nm	460nm
Δ CIE X Coordinate	-0.003	-0.002	0	0.001	0.001
Δ CIE Y Coordinate	-0.014	-0.007	0	0.005	0.008

Absolute Maximum and Minimum Ratings

Description	Maximum Values
Maximum operating temperature (Tmax ¹)	110°C
Minimum operating temperature	-40°C
Max storage temperature	110°C
Minimum storage temperature	-40°C
Response time to full light output	<10µs

¹Tmax is the maximum temperature measured on the inner surface of ChromaLit. Please consult application guide for additional information on measurement location.

Mechanical Characteristics for ChromaLit 360

Material Properties

Description	Properties
Substrate	Polycarbonate
Coefficient of Thermal Expansion	70 ppm/°C

ChromaLit Ellipse

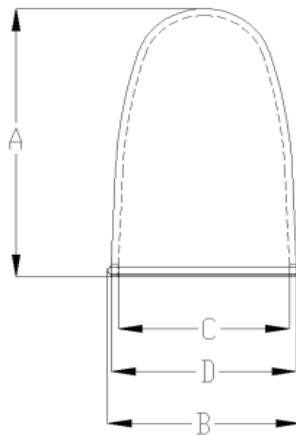

Dimension Designation	Example Application	Typical Lumen Output (lm) ¹	A. Height (mm/in. ²)	B. Maximum Diameter (mm/in. ²)	C. Inner Opening Diameter (mm/in. ²)	D. Outer Opening Diameter (mm/in. ²)	Thickness (mm/in. ²)
ELP 30	LED retrofit lamp/pathway lighting/chandelier	200-350	26.4/1.0	14.5/0.6	16.4/0.6	16.4/0.6	1.0/0.04
ELP 40		350-600	32.9/1.3	20.0/0.8	22.0/0.9	22.0/0.9	1.0/0.04
ELP 60		550-850	40.4/1.6	23.5/0.9	25.5/1.0	25.5/1.0	1.0/0.04

ChromaLit Candle

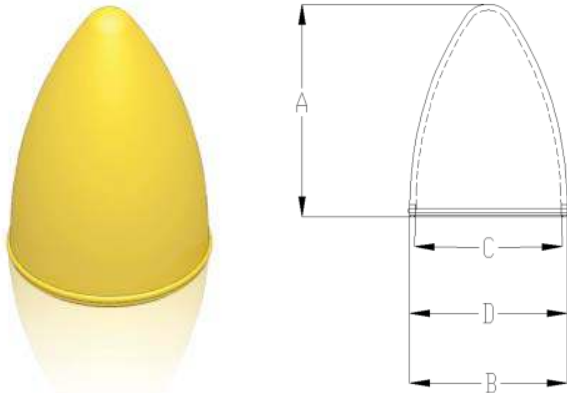

Dimension Designation	Example Application	Typical Lumen Output (lm) ¹	A. Height (mm/in. ²)	B. Maximum Diameter (mm/in. ²)	C. Inner Opening Diameter (mm/in. ²)	D. Outer Opening Diameter (mm/in. ²)	Thickness (mm/in. ²)
CAN 15	LED retrofit lamp/lantern/chandelier	70-150	16.0/0.6	11.9/0.5	9.5/0.4	11.4/0.4	1.0/0.04
CAN 30		150-300	21.2/1.0	16.9/0.7	14.5/0.6	16.4/0.6	1.0/0.04
CAN 40		300-700	35.0/1.4	26.6/1.0	24.0/0.9	26.0/1.0	1.0/0.04

ChromaLit Dome 15

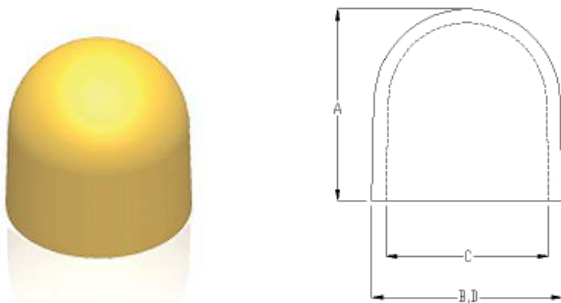

ChromaLit Dome 40, 60, 100

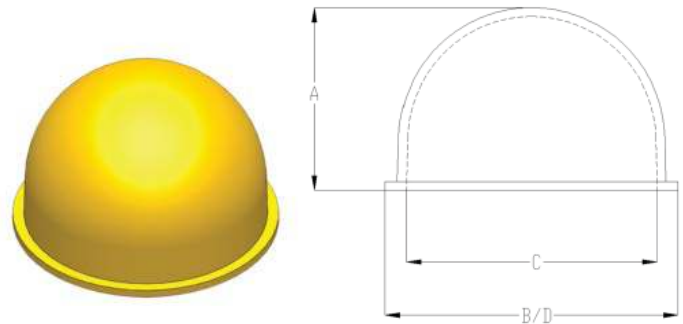

Dimension Designation	Example Application	Typical Lumen Output (lm) ¹	A. Height (mm/in. ²)	B. Maximum Diameter (mm/in. ²)	C. Inner Opening Diameter (mm/in. ²)	D. Outer Opening Diameter (mm/in. ²)	Thickness (mm/in. ²)
DOM 15	single LED	100-200	13.8/0.5	14.0/0.6	12.0/0.5	14.0/0.6	1.0/0.04
DOM 40	LED retrofit lamp/wall sconces/pendants	300-600	20.5/0.8	33.00/1.3	28.0/1.1	33.0/1.3	1.0/0.04
DOM 60		600-1000	26.1/1.0	42.0/1.7	37.0/1.5	42.0/1.7	1.0/0.04
DOM 100		1000-1600	34.1/1.3	55.0/2.2	50.0/2.0	55.0/2.2	1.0/0.04

1. Typical dimension tolerances for length, width, and diameter are ± 0.7 mm. Phosphor dimension and mechanical dimension are equivalent.

2. Typical lumen output is a recommended range based on typical application for a 3000K CCT, 80 CRI lighting system operating below maximum temperature specification. On a relative basis, lower CCTs/higher CRIs operate at lower lumen output and higher CCTs/lower CRIs may have higher lumen output. Max temperature and thus system lumens may vary widely depending on thermal management used.

Mechanical Diagram, ELP30

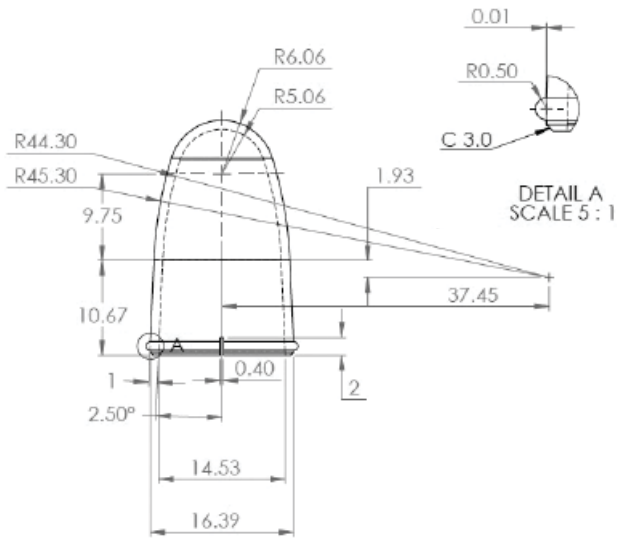

Mechanical Diagram, ELP40

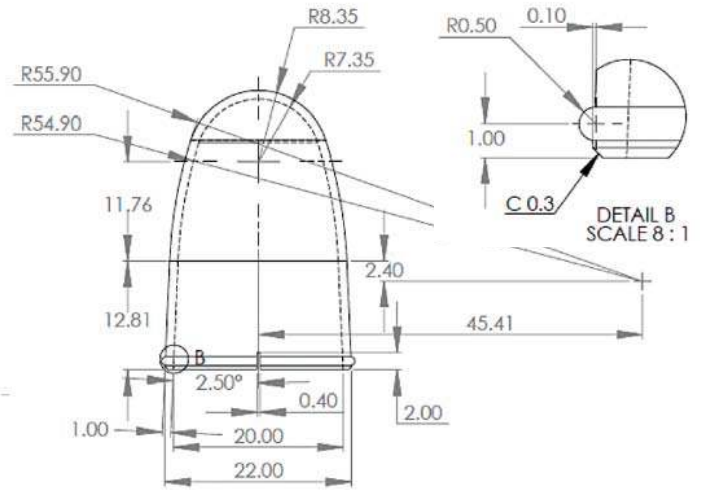

Mechanical Diagram, ELP60

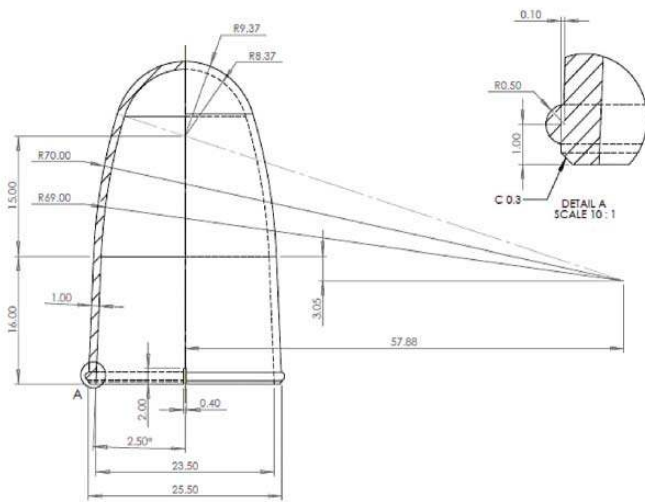

Mechanical Diagram, CAN15

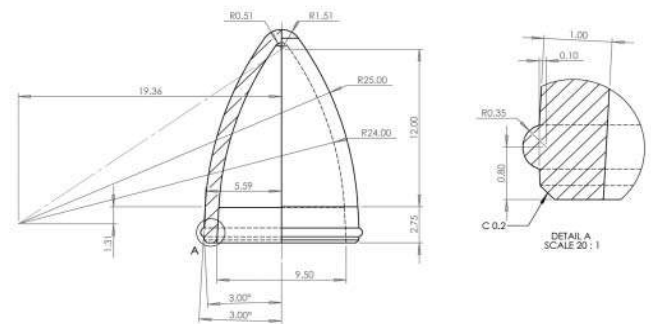

Mechanical Diagram, CAN30

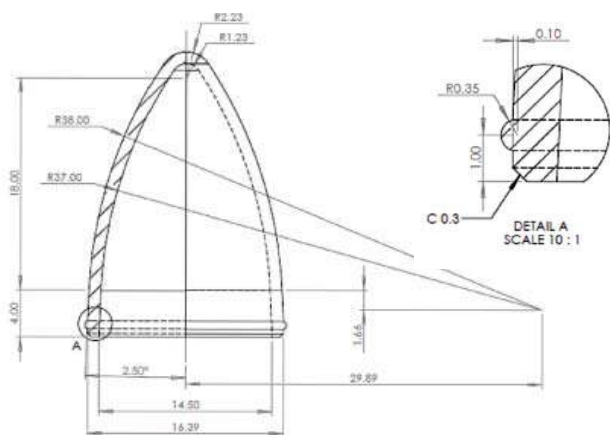

Mechanical Diagram, CAN40

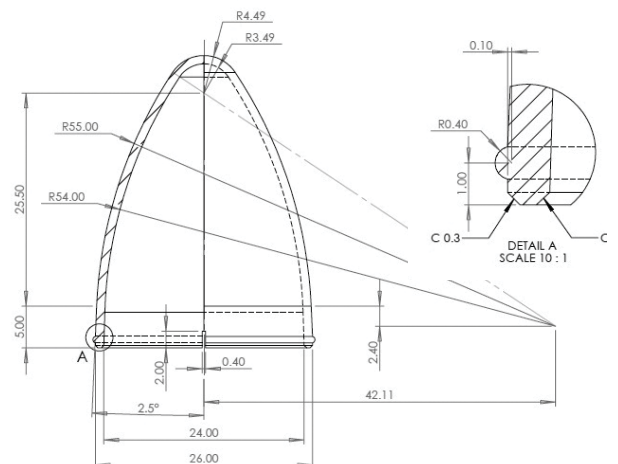

Mechanical Diagram, DOM15

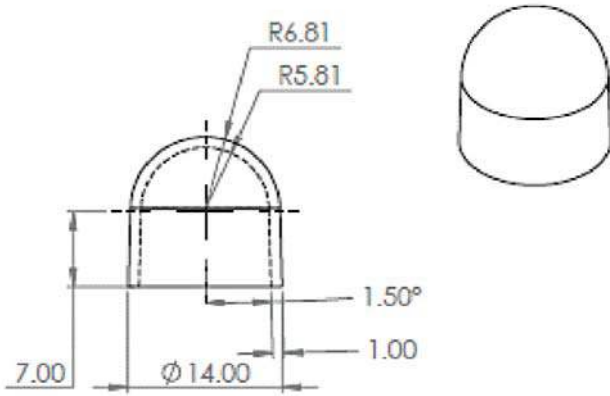

Mechanical Diagram, DOM40

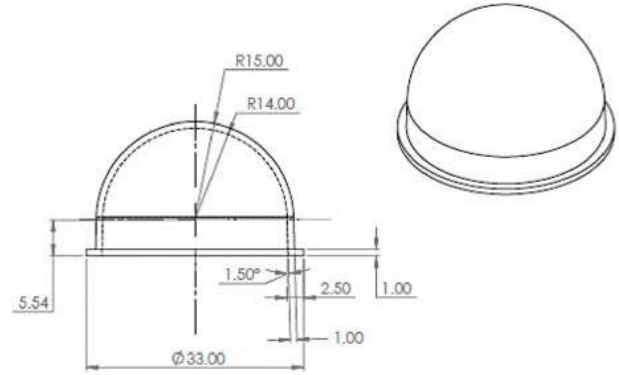

Mechanical Diagram, DOM60

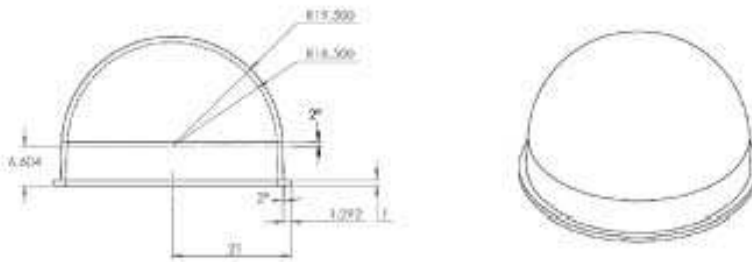

Mechanical Diagram, DOM60

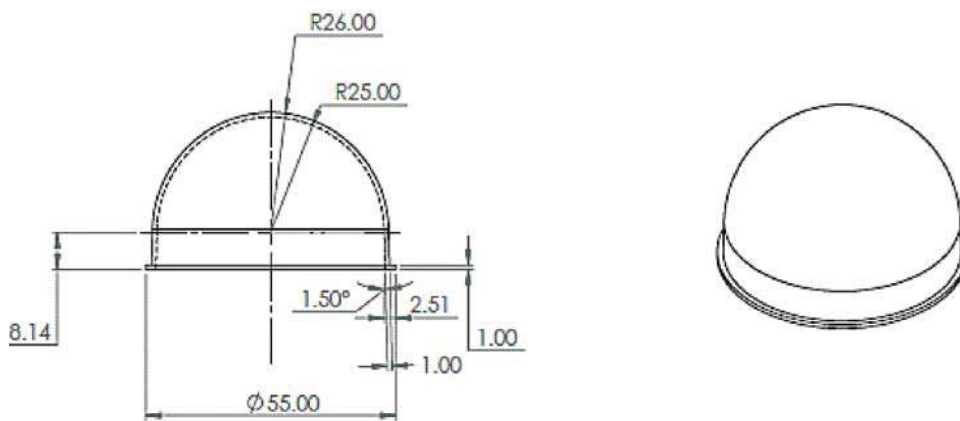

Reliability and Environmental Ratings

Description	Typical Values
TLumen maintenance	L70 50K hours at 85°C
Storage life	50K hrs
Storage humidity (non-condensing)	90%
RoHS	RoHS Compliant
REACH	REACH Compliant

Handling Considerations

As a dirty or damaged phosphor layer could result in alteration in product performance, ChromaLit light sources should be handled similarly to most optical components. It is best to handle the parts at the edges and prevent mechanical abrasion. If adhesives are used, they must be kept off of the entrance or exit apertures of ChromaLit, since they could greatly impact performance. If parts require cleaning, use a lint free tissue, isopropanol (IPA), or mild detergent. Dry using compressed air.

About Intematix

Intematix develops essential phosphor materials to drive the LED lighting revolution. The company's comprehensive range of products and solutions can be used to build foundations for the world's LED lighting products and systems including general lighting, displays, automotive and many others. A broad selection of products and innovative delivery systems accelerate time-to-market, improve light quality and efficacy and reduce costs. For more information, please visit www.intematix.com.

INTEMATIX

46410 Fremont Boulevard ● Fremont, CA 94538

Tel: +1 510.933.3300 ● Fax: +1 510.668.0793

sales@intematix.com

www.intematix.com