



M695SDM

Design Target

Revision 050212

M695SDM Voltage Controlled SAW Oscillator

DESCRIPTION

The M695SDM Voltage Controlled SAW Oscillator (VCSCO) is a single output low noise oscillator that incorporates an analog X2 frequency multiplier to provide an output frequency that is twice that of the fundamental VCSCO frequency.

The M695SDM makes use of IDT's RF circuit design capability and SAW technology to provide a high level of performance. The fundamental frequency VCSCO is implemented as a discrete circuit with varactor tuning to give the lowest possible phase noise. A SAW quartz delay line is the frequency controlling element in the oscillator resulting in low phase noise, temperature stability, and a repeatable linear tuning characteristic. An RF transistor is used for frequency multiplication.

The M695SDM VCSCO is manufactured on a 13x20 mm FR4 PCB. A Metal cover is used to protect the circuitry and provide RF shielding.

FEATURES

- Low jitter
 - 20 fs rms from 10 kHz to 50 MHz
- 13x20 mm Surface Mount FR4 PCB
- +5.0V Power Supply
- RoHS Compliant

APPLICATIONS

- Frequency Translation
- De-jitter Phase Lock Loop Applications
- Clock and Data Retiming
- Low Noise Clocks

ABSOLUTE MAX RATINGS

Operating Temperature: -20°C to 85°C

Storage Temperature: -55°C to 125°C

Power Supply Voltage: 5.5V

Tuning Voltage: -0.5V to +5.5V



SPECIFICATIONS

Specifications apply at $V_{cc} = 5.0V$ and $T_{case} = 25^{\circ}C$ unless otherwise specified

Parameter	Minimum	Typical	Maximum	Units	Notes
Center Frequency Range	1500		2100	MHz	Other frequencies available
Tuning Range		700		ppm	$V_{tune} = 0.0V$ to $5.0V$
APR	± 50			ppm	
Temperature Stability			250	ppm p-p	$-20^{\circ}C$ to $85^{\circ}C$
Power supply Pushing	-32		32	ppm/V	$V_{cc} = 5.0V \pm 2.5\%$
Kvco		165		ppm/V	
Tuning Linearity	-8		8	%	Deviation from best linear fit
Output Power	8	10	12	dBm	50 Ω load
Harmonic Spurious			-30	dBc	
Sub-harmonic Spurious			-30	dBc	
Non-harmonic Spurious			-60	dBc	
VSWR, all phases			3:1		
SSB Phase Noise					
$\Delta f = 10$ kHz		-120		dBc/Hz	
$\Delta f = 100$ kHz		-140		dBc/Hz	
$\Delta f = 1$ MHz		-162		dBc/Hz	
$\Delta f = 10$ MHz		-165		dBc/Hz	
$\Delta f > 20$ MHz		-165		dBc/Hz	
RMS Jitter, 10 kHz to 50 MHz		20		fs	
Vcc	4.750	5.0	5.250	Volts	
Icc		60	75	mA	
Operating Temperature	-20		85	$^{\circ}C$	Case temperature

BLOCK DIAGRAM

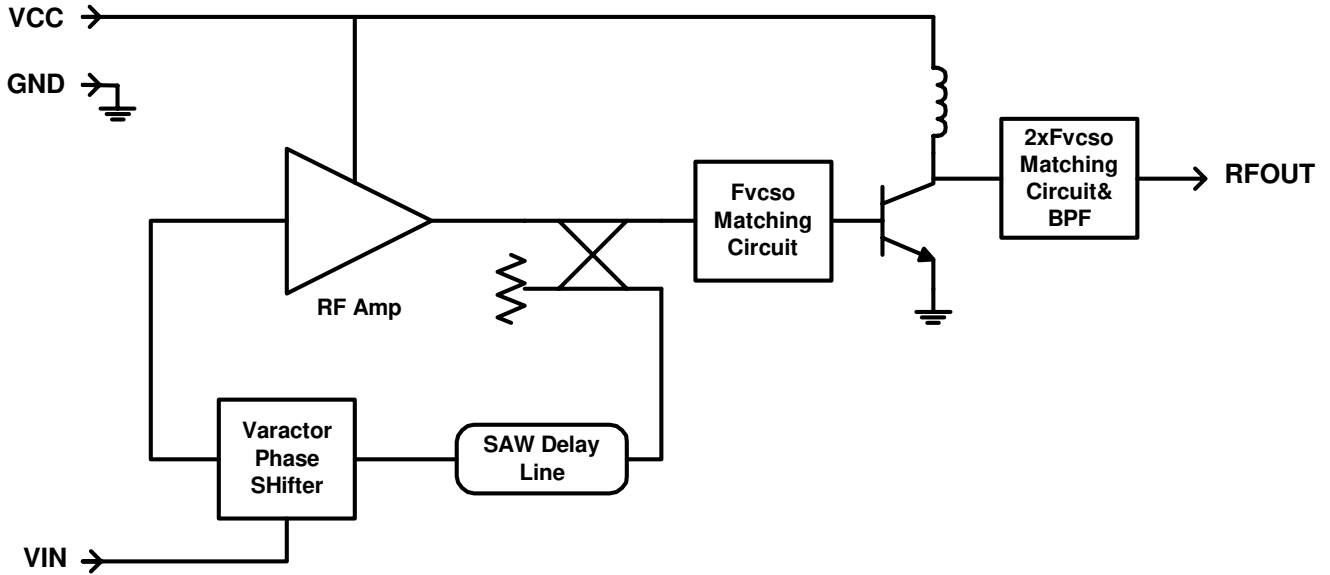

OUTLINE DRAWING

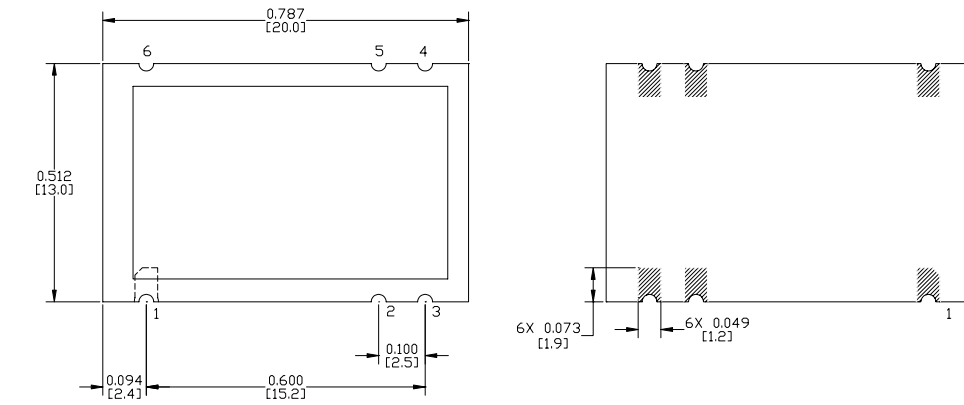

PIN CONNECTIONS

PIN 1	Vin (TUNING VOLTAGE)
PIN 2	NO CONNECTION
PIN 3	GROUND
PIN 4	RF OUTPUT
PIN 5	NO CONNECTION
PIN 6	VCC

Pad Finish: Gold over Nickel
 Moisture Sensitivity: Level 1



Ordering Information

Part Numbering Scheme

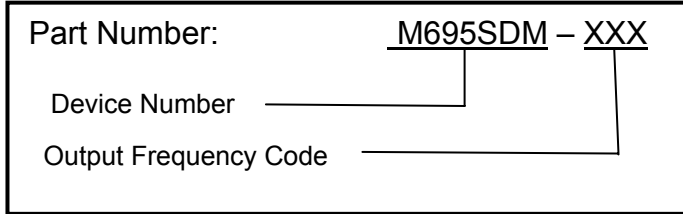

Output Frequencies & Order Codes

Output Frequency Code	Output Frequency MHz
T01	1747.623000
T02	1747.030837
T03	1748.366885
T04	1748.793733
T05	2050.000000
T06	2000.000000
T07	1968.750000

Consult IDT for availability of other frequencies