

TRADE MARK

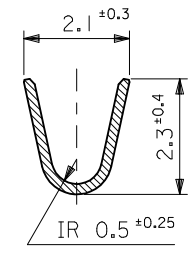

SECT. A-A

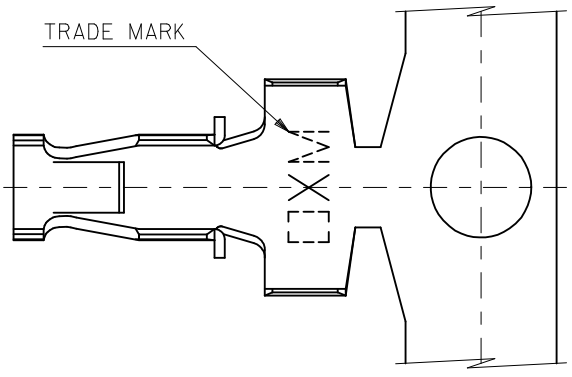
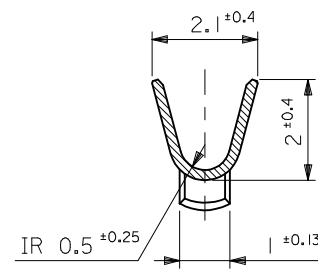

SECT. B-B

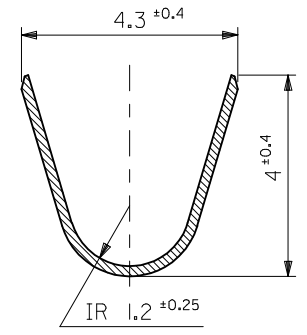

SECT. C-C

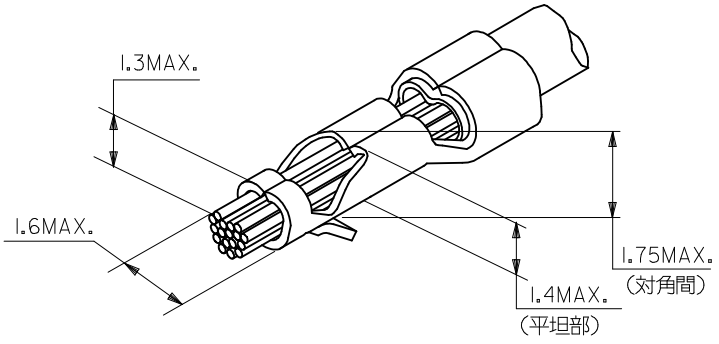
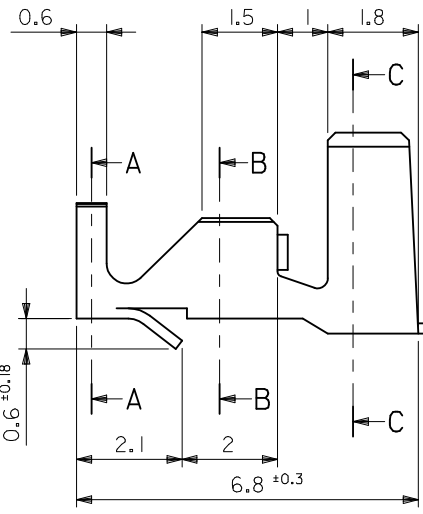

圧着外観図
OUTSIDE VIEW OF CRIMP

NOTES

- 推奨プリント基板孔径: $\phi 1.8^{+0.1}$
RECOMMENDED P.C.B. HOLES: $\phi 1.8^{+0.1}$
- 推奨プリント基板厚: $t1.57^{+0.2}$
RECOMMENDED P.C.B. THICKNESS: $1.57^{+0.2}$
- 材料の厚み: 0.203
MATERIAL THICKNESS: 0.203

TIN-LEAD(90-10) 3.8 μ m MIN. OVER NICKEL 1.3 μ m MIN.	PHOSPHOR BRONZE	CHAIN	39-00-0277	5298PBPT
TIN 0.9 μ m MIN. REFLOW TREATMENT (PRE-PLATED)	PHOSPHOR BRONZE	CHAIN	39-00-0230	5298PBT
TIN 0.9 μ m MIN. OVER COPPER 0.5 μ m MIN. (PRE-PLATED)	BRASS	CHAIN	08-70-0106	5298T
PLATING		MATERIAL	FORM	EDP NO.
				ENG. NO.

材料 MATERIAL	SEE TABLE & NOTE
仕上げ FINISH	—
適用電線範囲 WIRE RANGE	AWG #18-22
被覆外径 INS. RANGE	$\phi 1.7-3.05$

REVISED	EC NO. J2017-0224	DRW: NISHIKAWA 2016/10/12	CHK: K.TAKAHASHI 2016/10/12	APP: M.SASAO 2016/10/14
DESCRIPTION				
REV				

GENERAL TOLERANCES (UNLESS SPECIFIED)		
0.25 UNDER	±	
0.25 OVER 0.5 UNDER	±	
0.5 OVER 1.0 UNDER	±	
10 OVER 10 UNDER	±0.2	
30 OVER	±0.25	
30 OVER	±0.3	
ANGULAR	±3 °	
DRAFT WHERE APPLICABLE MUST REMAIN WITHIN DIMENSIONS		

DIMENSION STYLE		SCALE	DESIGN UNITS	THIRD ANGLE PROJECTION
MM ONLY			METRIC	
DRAWN BY	DATE	TITLE		
H.HIRAMOTO	'91/09/05	LOW PROFILE PC BOARD CRIMP PIN		
CHECKED BY	DATE			
H.HIRAMOTO	'93/07/06			
APPROVED BY	DATE			
M.FUKUSHIMA	'93/07/06	MATERIAL NO.		
SEE TABLE		SD-5298-001		

MATERIAL NO.		DOCUMENT NO.	SHEET NO.
SEE TABLE		SD-5298-001	1 OF 1
THIS DRAWING CONTAINS INFORMATION THAT IS PROPRIETARY TO MOLEX ELECTRONIC TECHNOLOGIES, LLC AND SHOULD NOT BE USED WITHOUT WRITTEN PERMISSION			