

PART NAME: KNOB SCALE: 1:1 DATE: 1/18/05 DR. BY JAM

DAVIES MOLDING COMPANY
CAROL STREAM, ILLINOIS 60188

P/N	1506-H
MOLD #	1505/1506/2813
CAVITY	1506
CORE	1506
PIN	BP1506-H

THIS DRAWING IS THE PROPERTY OF DAVIES MOLDING COMPANY, IS SUBMITTED SOLELY AS A DESIGN OR ENGINEERING PROJECT. WE ACCEPT NO RESPONSIBILITY WHATSOEVER FOR THE PRACTICAL APPLICATION OF THE PIECES MADE TO THIS DESIGN.

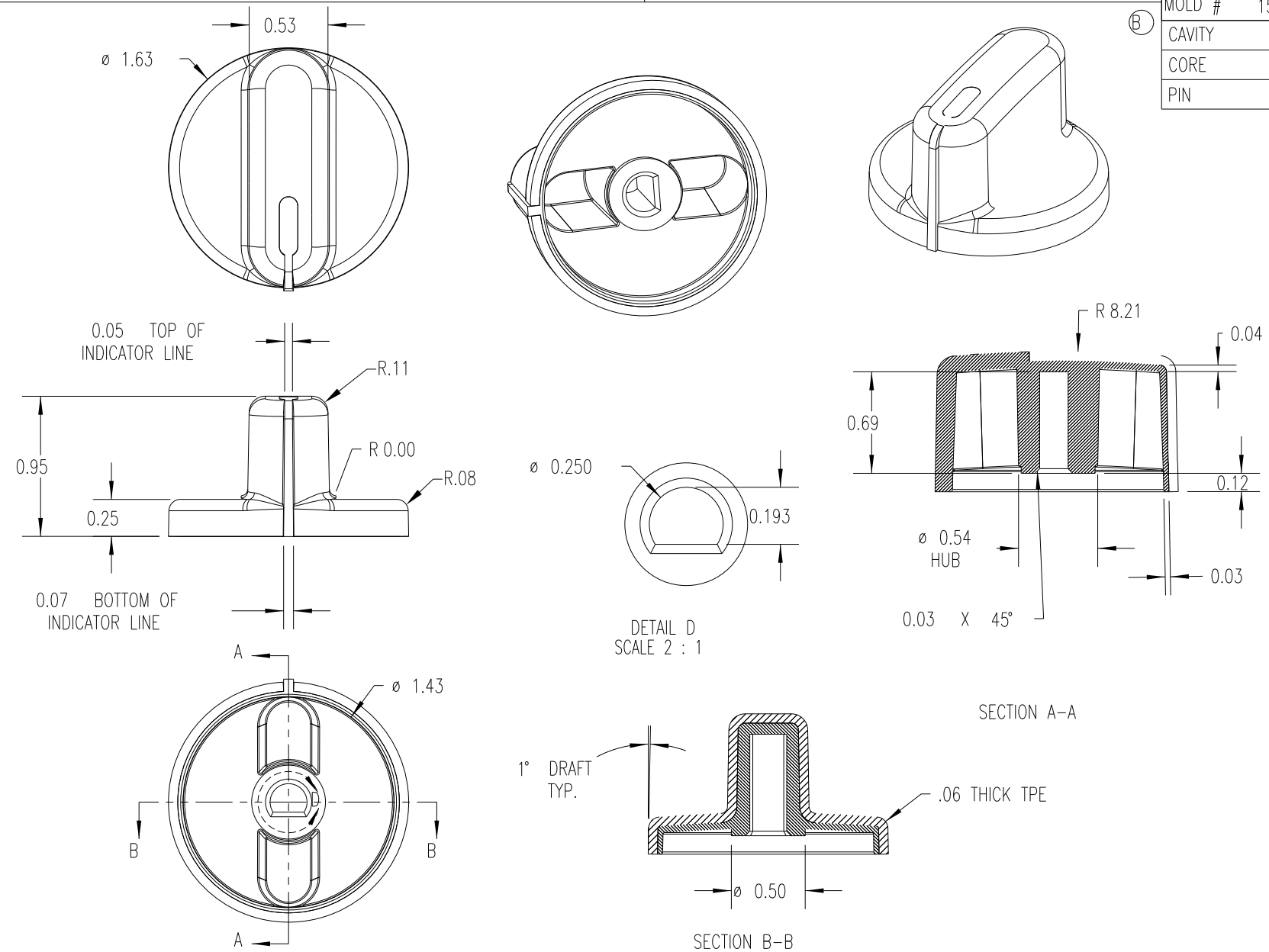

OVERMOLD MATERIAL: TPE (TPE3)
 COLOR: BLACK
 SUBSTRATE MATERIAL: POLYPROPYLENE (CLD)
 COLOR: WHITE (COLOR #: PC23083 CHROMA)

TOLERANCES: UNLESS OTHERWISE SPECIFIED	DO NOT SCALE DRAWING	B	MOLD # WAS 1506	JAM	12/14/09
DECIMALS: X.XXX ± .005 X.XX ± .015	MM: X.XX ± 0.15MM X.X ± 0.4MM	A	ADDED COLOR CODE	DS	8/25/06
FRACTIONS ± 1/64	ANG. ± 1°	-	WAS SK1506-06	JAM	6/6/05
CHANGES					