

TCP/IP protocol stack for SPWF04Sx Wi-Fi modules

Introduction

The SPWF04Sx series of Wi-Fi modules integrate a complete TCP/IP protocol stack and a rich set of applications including, but not limited to, web server, web client RESTful API, TFTP, MQTT and SMTP.

Security is added in the multiple layers of Wi-Fi and peer-to-peer protocols. The stack implements the WPS protocol, WPA2 in both the Personal and Enterprise options, and the TLS for end-to-end secure transactions.

Users access the features of the SPWF04Sx modules via UART using the simple AT command syntax, or via SPI using a custom packet format and protocol.

To enable a complete customization of the application on the module, the SPWF04Sx software integrates a MicroPython interpreter that provides the user with MicroPython standard libraries and a customized set of classes to export the specific SPWF04Sx features.

The diagram below summarizes the possible integrations of an SPWF04Sx module in a target application.

Figure 1. SPWF04Sx user integration modes

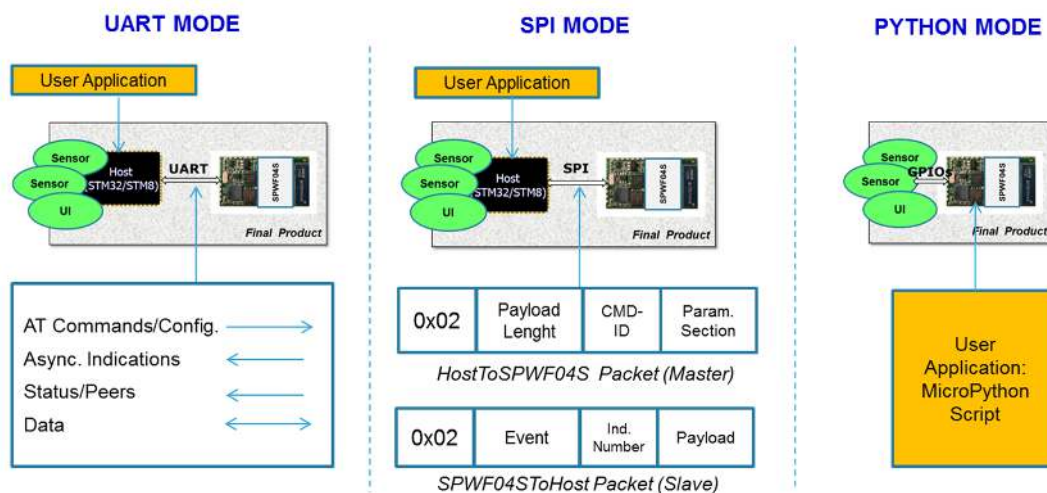

This user manual is intended as a guide to the set of commands available on the UART or the SPI console. A description and explanation of the configuration variables, status variables and asynchronous indication messages is available in the Appendix of the manual.

This manual is not intended as a technical guide of Wi-Fi and TCP/IP, or other technologies available in the module.

1 SPWF04Sx software architecture description

The complete SW architecture of SPWF04S is shown in the diagram below.

Figure 2. SPWF04Sx software architecture

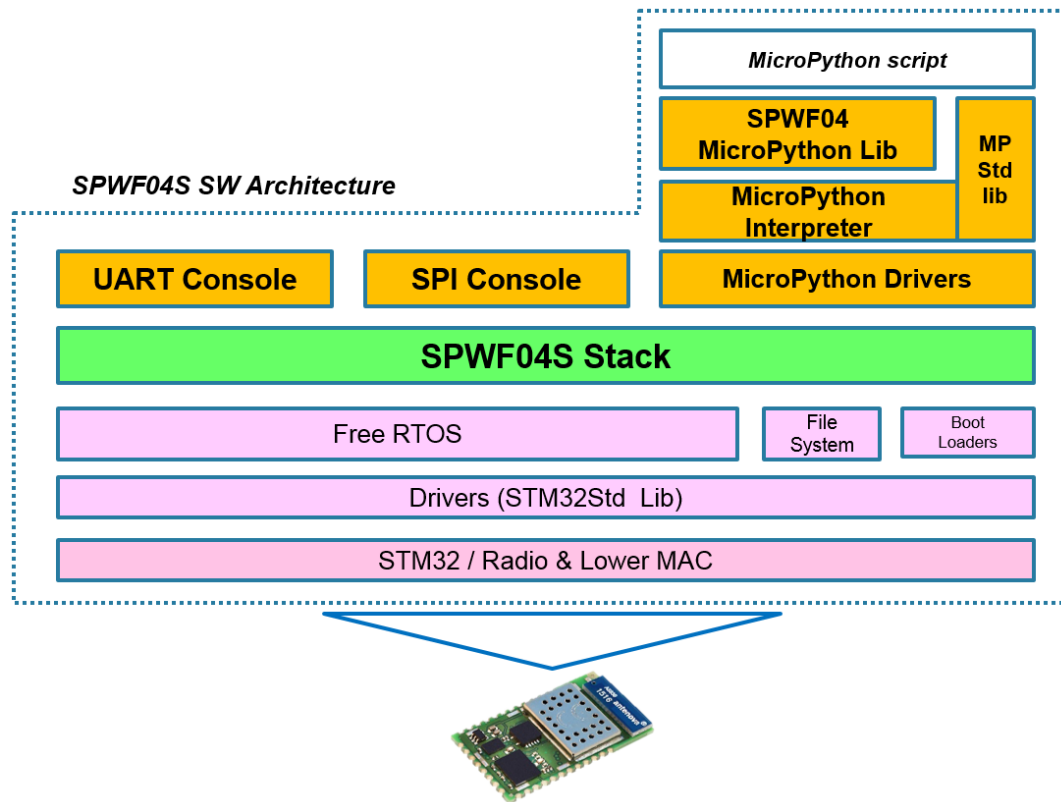

A block diagram of the SPWF04Sx protocol stack is provided in [Figure 3. SPWF04Sx protocol stack diagram](#).

Figure 3. SPWF04Sx protocol stack diagram

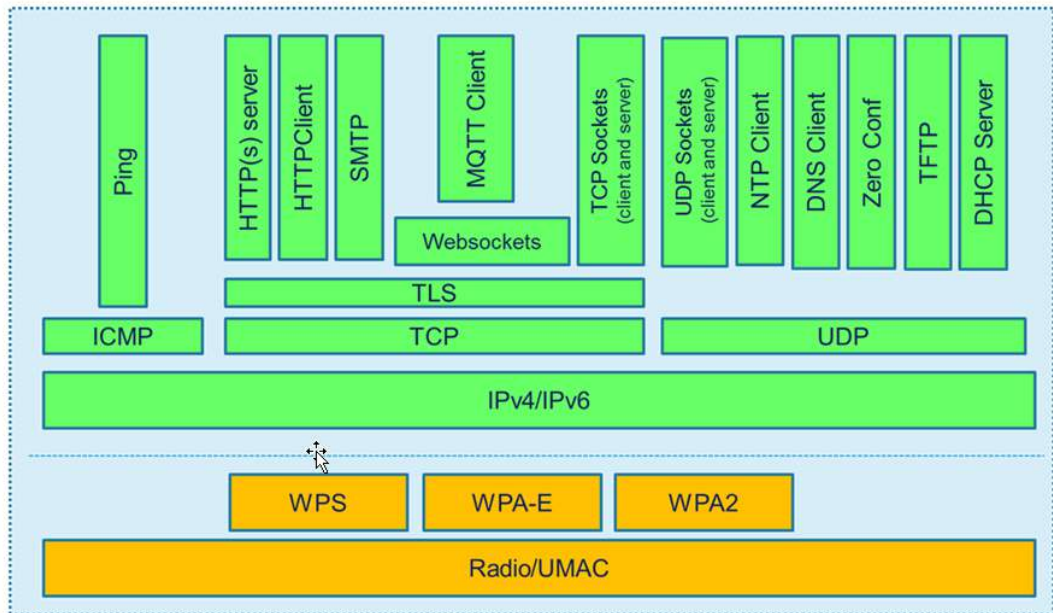

2 Interface and message types

As shown in [Figure 1. SPWF04Sx user integration modes](#), the SPWF04Sx enables three options for integration of the device in the final user application. Refer to the SPWF04Sx datasheet for information useful for implementation, such as the pinout. The configuration variable, “console_enabled”, is used to define the module interface to use.

- **UART interface**

“console_enabled=1”

The UART console provides a user-friendly interface built on a set of AT commands that allow an external microcontroller connected to the SPWF04Sx UART to access the functions integrated in SPWF04Sx device. UART is set as the module’s default interface.

- **SPI interface**

“console_enabled=0”

The device can be connected as a slave to the SPI interface of an external microcontroller. An ad hoc SPI protocol and corresponding packet format are defined.

- **MicroPython scripting**

“console_enabled=2” - to use Python together with AT commands over UART.

“console_enabled=3” - to use MicroPython only.

The device implements a scripting methodology based on an integrated MicroPython interpreter. MicroPython scripts can map a target application, making it unnecessary to integrate the device with an external processor.

The following four message types represent the type of data exchanged over the interfaces.

- **Commands**

Used to activate a feature defined within the stack. The list of commands supported is specified in [Table 1. SPWF04Sx commands](#).

- **Command return messages**

Synchronous messages that report the status of the execution of a command. The list of synchronous error codes is reported in [Section 8](#) in the Appendix.

- **WINDs**

Asynchronous messages reporting a network or radio status at the application level. The list of WIND messages is reported in [Section 8](#) in the Appendix.

- **Data**

Data sent to, or received (data payload) from, a remote device.

Table 1. SPWF04Sx commands

Command ID	AT command	Description
Utils: commands for debugging and retrieving module status		
0x01	AT	Null command
0x02	AT+S.HELP	Help command
0x05	AT+S.STS	Status configuration
0x35	AT+S.PEERS	Peers configuration
Management: commands for module management and configuration		
0x03	AT+S.RESET	SW reset
0x04	AT+S.PMS	Set power mode
0x08	AT+S.PYTHON	Enter MicroPython execution
0x09	AT+S.GCFG	Read Configuration status

Command ID	AT command	Description
0x0A	AT+S.SCFG	Set configuration variables
0x0B	AT+S.WCFG	Save configuration to Flash
0x0C	AT+S.FCFG	Restore factory configuration
0x57	AT+S.FSWRITE	FS update via serial UART/SPI
0x58	AT+S.FSUPDATE	FS download
0x56	AT+S.FWUPDATE	FW download
STM32 peripherals: commands to manage the peripherals and related values		
0x13	AT+S.GPIOC	Configure GPIO
0x14	AT+S.GPIOR	Read GPIO
0x15	AT+S.GPIOW	Write GPIO
0x16	AT+S.DAC	Disable/Enable DAC
0x17	AT+S.ADC	Read ADC value
0x18	AT+S.PWM	Set PWM
0x11	AT+S.TIME	Get/Set time
0x12	AT+S.RANDOM	Provide random number
File system management		
0x21	AT+S.FSM	Mount volume
0x22	AT+S.FSU	Umount/Erase volume
0x23	AT+S.FSC	Create file, append data
0x25	AT+S.FSD	Delete file
0x26	AT+S.FSR	Rename file
0x27	AT+S.FSL	List existing files
0x28	AT+S.FSP	Print file content
0x29	AT+S.HASH	Compute digest
Security: commands to interact with the security features		
0x2A	AT+S.WPAECERT	Manage WPA-Enterprise certificates
0x2B	AT+S.TLSCERT	Manage TLS certificates
0x36	AT+S.WPS	Initiate a WPS Exchange
Radio: commands to manage main Wi-Fi operations		
0x32	AT+S.WIFI	Set Wi-Fi radio
0x33	AT+S.SCAN	Network scan
0x34	AT+S.SSIDTXT	Get/Set ASCII SSID
0x39	AT+S.PING	Ping a specified host
Sockets: commands to manage socket read and write		
0x41	AT+S.SOCKON	Open a socket client
0x42	AT+S.SOCKQ	Query a socket client for pending data
0x43	AT+S.SOCKC	Close a socket client
0x44	AT+S.SOCKW	Write data to a socket server
0x45	AT+S.SOCKR	Read data from a socket client
0x46	AT+S.SOCKL	List opened socket clients

Command ID	AT command	Description
0x47	AT+S.SOCKDON	Open a socket server
0x48	AT+S.SOCKDQ	Query socket server for pending data
0x49	AT+S.SOCKDC	Close a socket server
0x4A	AT+S.SOCKDW	Write data to a socket server
0x4B	AT+S.SOCKDR	Read data from a socket server
0x4C	AT+S.SOCKDL	List bound socket clients
Web sockets		
0x61	AT+S.WSOCKON	Open a web socket client
0x62	AT+S.WSOCKQ	Query a web socket client for pending data
0x63	AT+S.WSOCKC	Close web socket client
0x64	AT+S.WSOCKW	Write data to a web socket client
0x65	AT+S.WSOCKR	Read data from web socket client
0x66	AT+S.WSOCKL	List open web socket client
Trivial FTP		
0x51	AT+S.TFTPGET	Get request to a TFTP server
0x52	AT+S.TFTPPUT	Put request to a TFTP server
SMTP		
0x53	AT+S.SMTP	Send an email
HTTP		
0x54	AT+S.HTTPGET	Get a request to an HTTP server
0x55	AT+S.HTTPPOST	Post request to an HTTP server
0x59	AT+S.INPUTSSI	Fill buffer for raw text input SSI
MQTT		
0x5A	AT+S.MQTTCONN	MQTT connect
0x5B	AT+S.MQTTSUB	MQTT subscribe
0x5C	AT+S.MQTTPUB	MQTT publish
0x5D	AT+S.MQTTUNSUB	MQTT unsubscribe
0x5E	AT+S.MQTTDISC	MQTT disconnect

3 AT commands over the UART

The factory module configuration sets the UART console mode as the default interface for the SPWF04Sx. This corresponds to the configuration variable “console_enabled” being set to 1.

AT commands over the UART have a max length of 512 bytes; they are case insensitive and are always in the form of:

AT+S. *<cmd-parameters><cr>[data]*

Note: Any command requiring data after the <cr> is not reentrant. If bytes are lost during data transfer over the UART, the module remains in the waiting stage for incoming bytes.

A command is followed by a variable number of response lines that have the following format:

AT-S. *<response-string><optional-parameters>*

The AT command line, up to the terminating <cr>, is sent from the host. Response lines are sent from the module to the host.

AT-S.OK:<free_heap>:<wifi_state>

returned when a command is successfully executed.

Note that free_heap and wifi_state are shown depending on the "console_verbose" configuration variable value (0 to 2).

AT-S.ERROR:<error-code>:<error-string>

qualifies a synchronous error. The <error-code> field of each asynchronous indication type is unique. The descriptive string may be safely ignored.

Note that error_code and error_string are shown depending on the "console_errs" configuration variable value (0 to 2).

Command parameters

A command can require parameters that follow an “=” character. The parameters are positional and separated by a configurable separator (by default, a comma).

Parameters can require mandatory or optional values. In the latter case, if the value is not specified a default value will be used. In the format of the command, an optional parameter is represented in squared brackets.

Asynchronous indications

Asynchronous indications may arrive at any time (except as noted below), and have the format:

+WIND:<number>:<descriptive-string>[:<variables>]<cr><lf>

The <number> field of each asynchronous indication type is unique. The descriptive string may be safely ignored.

Note that number and descriptive strings are shown depending on the "console_winds" configuration variable value (0 to 2).

Refer to [Section 8](#) in the Appendix for a complete list of WIND messages.

Note: Immediately after reset, no commands should be sent and only asynchronous indications are present until the indication “+WIND:0:Console active<cr><lf>” is received. After this event, AT commands may be safely sent to the device.

4 SPI protocol

By setting to 0 the configuration variable "console_enabled", the module is enabled to use the SPI interface in place of the UART.

The data transferred over the MISO and MOSI signals are packed using a well-defined API packet format as represented below.

Figure 4. SPI packet formats

Master SPI Packet Format

0x02 (1 byte)	Payload Length (2 bytes)	Payload (Length bytes)
------------------	-----------------------------	---------------------------

Master SPI Packet Payload

CMD ID (1 byte)	Number of parameters (1 byte)	Len 1 st parameter (1 byte)	Payload 1 st parameter (Len bytes)	All other parameters	Len N th parameter (1 byte)	Payload N th parameter (Len bytes)
--------------------	----------------------------------	---	--	----------------------	---	--

Slave SPI Packet Format

0x02 (1 byte)	KindOfEvent (1 byte)	Indication Number (1 byte)	Payload Length (2 bytes)	Payload (Length bytes)
------------------	-------------------------	-------------------------------	-----------------------------	---------------------------

Table 2. KindOfEvent Byte SubField

Bits	Event type
Bits 0:3	Status variable wifi_state values range. Refer to Table 8. Status variables .
Bits 4:7	Allowed values are: <ul style="list-style-type: none"> 0x01 for common indications like WIND or action confirmations 0x02 for critical error notifications 0x03 for incoming data sent over the SPI (in this case normally data are filled into payload field)

Table 3. Indication number field

Event type Bits 4:7	Indication number
0x01	Refer to Table 14. WIND messages .
0x02	Refer to Table 10. AT-S.ERROR:=ERROR ID= =ERROR String= .
0x03	Data payload.

Commands over the SPI have a max length of 512 bytes.

To map an AT command in the equivalent SPI command, the following procedure applies:

1. Use the corresponding CMD ID specified in [Table 1. SPWF04Sx commands](#) and fill the 4th bytes of the master packet.
2. If optional parameters are available, count the number of comma-separated items after the "=" character and with that number the 6th byte of the message. Starting from the 7th byte, start to write 1 byte containing the field lengths and then copy the field bytes. Then continue with the remaining parameters.

3. Once the full payload has been filled, calculate the full message payload lengths and accordingly fill bytes 1 and 2 in the SPI message packet request.

First example

AT command: AT+S.FSL

1. Command ID: 0x25
2. Number of parameters: 0x00
3. Full message payload length: 0x02

Result: SPI message 0x02 0x00 0x02 0x25 0x00

Second example

AT command: AT+S.SCAN=d,/scan.txt

1. Command ID: 0x33
2. Number of parameters: 0x02
 - a. First Parameter: 0x01,d
 - b. Second Parameter: 0x09,"/scan.txt"
3. Full message payload length: 0x0D

Result: SPI Message 0x02 0x00 0x0D 0x33 0x02 0x01 d 0x09 "/scan.txt"

Third example

AT command: AT+S.SOCKW=0,5<Cr>hello

1. Command ID: 0x44
2. Number of parameters: 0x02
 - a. First Parameter: 0x01,0
 - b. Second Parameter: 0x01,5
3. Payload: "hello"

Result: SPI Message 0x02 0x00 0x0B 0x44 0x02 0x01 0 0x01 5 "hello"

Fourth example

Asynchronous event: +WIND:1:Poweron:170726-b7ac1ba-SPWF04S

1. kind of event (4bits): 0x01
2. wifi_state (4 bits): 0x0
3. Indication number: 0x01
4. Full message payload length: 0x16

Result: SPI Message 0x02 0x10 0x01 0x16 0x00 (170726-b7ac1ba-SPWF04S)

5 MicroPython scripting

The SPWF04Sx supports the MicroPython modes represented in [Figure 5. MicroPython modes](#). The configuration variable "console_enabled" identifies the use of the console together with MicroPython. In detail:

- "console_enabled" set to 2: this setting allows using both AT commands over the UART and MicroPython REPL shell.
- "console_enabled" set to 3: this setting allows only a MicroPython preloaded script to be executed. No UART/SPI communication is allowed to/from a host processor.

Consequently, the following Python modes are defined:

- **Python Interactive Console (REPL – Read Evaluation Print Loop)**. Mainly used for debugging purposes, it is activated by the AT+S.Python (Python command) launched without parameters. The REPL is exited by using a CTRL-D escape character.
- **Run Time Script execution**. Activated with the Python command, it allows to execute the script specified as parameter. After script execution, control returns to the AT console.
- **DefaultScript Hard Execution**. By using the GPIO(8) set to high at boot time, or when "console_enabled" is set to 3, the module automatically enters the execution of the script specified by the variable "python_script". This mode allows the use of the module without a connected host. Note that "console_enabled" is not changed by GPIO(8) access: this means that on the subsequent reboot, accessing Python mode again will require GPIO(8) to be high.

Figure 5. MicroPython modes

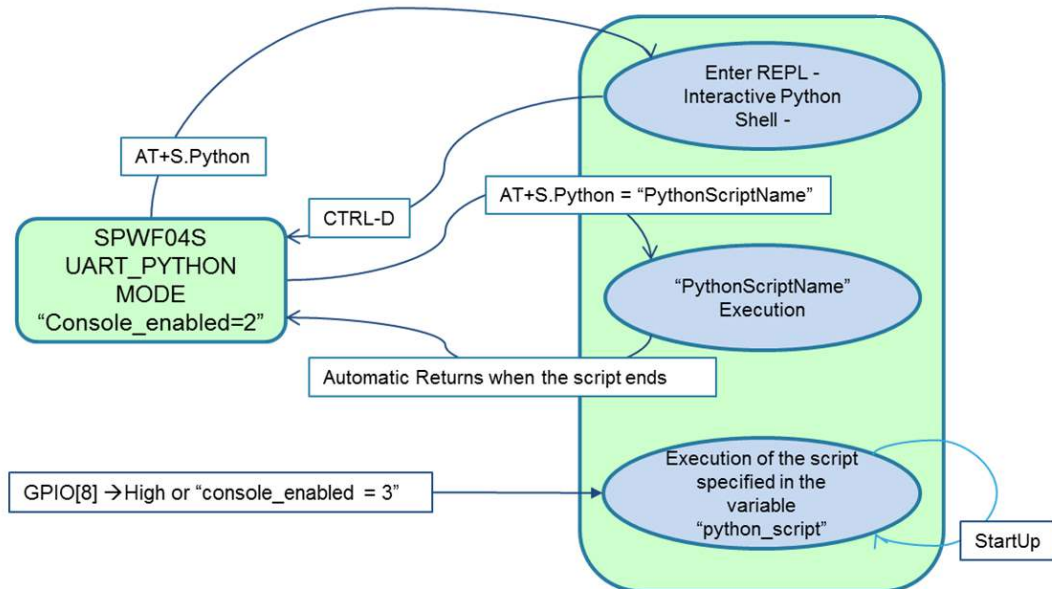

6 Command reference guide

This section details each of the SPWF04Sx commands listed in [Table 1. SPWF04Sx commands](#), including a brief description of its behavior and complete list of parameters. Examples and syntax are described in the “AT” format introduced in [Section 3 AT commands over the UART](#). The mapping mechanism described in [Section 4 SPI protocol](#) is used to map the AT command in the packet format used by the SPI.

6.1 AT

AT, by itself, is a null command that always returns an OK result code. It is useful for testing the module interface for readiness.

Usage:

```
AT<cr>
```

Parameters:

None

6.2 AT+S.HELP

AT+S.HELP prints the list of all the AT commands supported with a brief help text for each of them. Refer to [Table 1. SPWF04Sx commands](#) for a complete list of the commands available.

Usage:

- | | |
|----------------------------|--|
| 1) AT+S.HELP<cr> | to get the full list of commands |
| 2) AT+S.HELP=<keyword><cr> | to get the list of commands containing the specified keyword |

Parameters:

<keyword>	Specifies the name of a keyword
-----------	---------------------------------

Result:

AT-S.Command:<command> -- <help>	
<command>	Specifies the command
<help>	Specifies the description of the command

6.3 AT+S.STS

AT+S.STS displays the current values of all the status variables.

Usage:

- | | |
|----------------------------|---|
| 1) AT+S.STS<cr> | to get the full list of configuration variables |
| 2) AT+S.STS=<variable><cr> | to get the value of the specified variable |

Parameters:

<variable> Specifies the name of a variable. See [Table 8. Status variables](#) for a list of the available status variables

Result:

AT-S.Var:<var>=<value>

<var> Specifies the status variable name

<value> Specifies the status variable value

6.4 AT+S.PEERS

AT+S.PEERS displays the current values of the peer table. These values are useful to obtain additional information about the module connected to the AP or about the client connected to the module when it is configured in Mini AP mode.

Usage:

- | | |
|--|---|
| 1) AT+S.PEERS<cr> | returns the list of peers variable |
| 2) AT+S.PEERS=<peer_number><cr> | returns the list of peers variable for the peer_number peer |
| 3) AT+S.PEERS=<peer_number>,<peer_var><cr> | returns the specific value of a peer_variable |

Parameters:

<peer_number> identifier of the peer

<peer_var> displays the current value of the specified peer variable. Refer to [Table 9. Peer variables](#) in the Appendix for a complete list of the peer variables

Result:

AT-S.Var:<id>.<var>=<value>

<id> Specifies the peer number

<var> Specifies the peer variable name
 <value> Specifies the peer variable value

6.5 AT+S.RESET

Command used to provide a SW reset to the module.

Usage:

```
AT+S.RESET<cr>
```

Parameters:

None

6.6 AT+S.PMS

The SPWF04Sx features different power states as a consequence of the different operating modes of the radio and the STM32 microcontroller. This command is used to manage the module power state.

The table that follows summarizes the power state conditions supported by the module. The values of the variables affecting the output of the command are also reported in the following table.

Table 4. Power states and configuration

Module state	<Mode> option value	STM32 state	WLAN state	AT variable default values
Active	0	Run	Rx Idle Rx Active Tx Active	AT+S.SCFG=sleep_enabled,0 AT+S.SCFG=wifi_powersave,0 AT+S.SCFG=standby_enabled,0
PowerSave ⁽¹⁾	1	Run	PS or Fast PS	AT+S.SCFG=sleep_enabled,0 AT+S.SCFG=standby_enabled,0 AT+S.SCFG=wifi_powersave,1
Sleep ⁽¹⁾	2	Stop	PS or Fast PS	AT+S.SCFG=sleep_enabled,1 AT+S.SCFG=standby_enabled,0 AT+S.SCFG=wifi_powersave,1
StandBy ⁽²⁾	3	Standby	Off	AT+S.SCFG=standby_enabled,1 AT+S.SCFG=sleep_enabled,0

1. Variables *wifi_beacon_wakeup*, *wifi_operational_mode*, and *wifi_listen_interval*, need to be set to the desired value.

2. The variable *standby_time* to be set to the desired value.

Usage:

```
AT+S.PMS=[<mode>]<cr>
```

Parameters:

<mode>

Default value: 0

Possible values:

- 0 → active mode
- 1 → powersave mode
- 2 → stop mode
- 3 → standby mode

6.7 AT+S.PYTHON

The command has a Python script executed when the file name is specified or allows to enter a Python shell when the option is not used.

Usage:

- | | |
|-------------------------------|--------------------------------------|
| 1) AT+S.PYTHON<cr> | to enter the MicroPython REPL shell. |
| 2) AT+S.PYTHON=<filename><cr> | to execute the specified script. |

Parameters:

<filename>	specifies the Python script to be executed. After the execution of the script the command returns to the AT console.
------------	--

6.8 AT+S.GCFG

This command lists all the configuration variables together with their current value.

Usage:

- | | |
|----------------------------|---|
| 1) AT+S.GCFG<cr> | to get the full list of configuration variables |
| 2) AT+S.GCFG=<cfg_var><cr> | to get the value of the specified variable |

Parameters:

<cfg_var>	configuration variable. Refer to Table 7. Configuration variables for a complete list of the configurable variables.
-----------	--

Result:

AT-S.Var:<var>=<value>

<var>	Specifies the configuration variable name
-------	---

<value>	Specifies the configuration variable value
---------	--

6.9 AT+S.SCFG

Command to set the value of the named configuration variable. The value is saved in the RAM until the command AT+S.WCFG is used.

Usage:

```
AT+S.SCFG=<key>,<value><cr>
```

Parameters:

<key>	variable to configure
<value>	value to be set

6.10 AT+S.WCFG

Command to save the configuration set to the Flash.

Usage:

```
AT+S.WCFG<cr>
```

Parameters:

None

6.11 AT+S.FCFG

Command to restore the factory configuration variables from the Flash. It is mandatory to run a reset (HW or SW) after a factory restore.

Usage:

```
AT+S.FCFG<cr>
```

Note: *HW factory restore of the variables is performed by pulling the pin GPIO0 high at power-up (until the "+WIND:1:Poweron" indication is printed). In order to use the HW factory reset (GPIO0 enabled) and FWUPDATE at the same time, see [Section 6.13 AT+S.FSUPDATE](#).*

Parameters:

None

6.12 AT+S.FSWRITE

The command is used to update the external volume via serial interface.

Note: *The HW flow control MUST be enabled in order to use the command via UART.*

Usage:

AT+S.FSWRITE=<length><cr>{data}

Parameters:

<length> Data length to send (in bytes)

6.13 AT+S.FSUPDATE

To download an updated file system from the named host and path. The downloaded image overwrites the existing one. In this case, the user needs to perform a backup of the current file system.

Usage:

```
AT+S.FSUPDATE=<mem>,<hostname>,[<path&queryopts>],[<port>],[<TLS>],[<username>],
[<passwd>]<cr>
```

Parameters:

<mem>	specifies the memory where the file system is saved. <ul style="list-style-type: none"> e → user Flash i → application Flash x → external memory volume
<hostname>	Target host. DNS resolvable name or IP address.
<path&queryopts>	Default:/fs.img. Document path and optional query arguments.
<port>	Default 80 (if TLS=0) or 443 (if TLS>0).
<TLS>	Default: 0. Values range: 0 → unsecured; 1 → autodetect; 2 → TLS
<username>	Default: none.
<passwd>	Default: none.

6.14 AT+S.FWUPDATE

This command downloads an updated firmware image located at the named host and path. The downloaded image is temporary stored in the internal Flash. The user should perform a procedure to save the content of the file system that will be overwritten during the process.

Note: *FWUPDATE can be invalidated by pulling GPIO0 high during the first reset after the execution of AT+S.FWUPDATE command. In this case, the external filesystem is erased and the FW update is not performed.*

Usage:

Note: *The HW factory reset pin (GPIO0) must be tight low during F/W update. The HW factory reset can be used after "+WIND:17:F/W update complete!"*

```
AT+S.FWUPDATE=e,<hostname>,[<path&queryopts>],[<port>],[<TLS>],[<username>],
[<passwd>]<cr>
```

Parameters:

<hostname>	Target host. DNS resolvable name or IP address.
------------	---

<code><path&queryopts></code>	Default: /fw.fota. Document path and optional query arguments. If a secure FOTA is required, the extension of the file needs to be ".sfota".
<code><port></code>	Default 80 (if TLS=0) or 443 (if TLS>0).
<code><TLS></code>	Default: 0. Values range: 0 → unsecured; 1 → autodetect; 2 → TLS
<code><username></code>	Default: none.
<code><passwd></code>	Default: none.

6.15 AT+S.GPIOC

Command used to configure the function of the various GPIOs on the module. GPIOs can be configured as inputs or outputs. When used as inputs, they generate an interrupt when the state changes that can be configured on the signal edge.

Usage:

- | | |
|--|----------------------------------|
| 1) <code>AT+S.GPIOC=<number>,out<cr></code> | to configure a gpio as an output |
| 2) <code>AT+S.GPIOC=<number>,in,[<interrupt>]<cr></code> | to configure a gpio as an input |

Parameters:

<code><number></code>	GPIO Number (see Datasheet) Default: No interrupt (turn it off, if enabled). It can assume one of the following values:
<code><interrupt></code>	<ul style="list-style-type: none"> • R → Rising edge • F → Falling edge • B → Both rising and falling edges

6.16 AT+S.GPIOR

AT+S.GPIOR is used to read the value and the direction of a previously-configured GPIO.

Usage:

```
AT+S.GPIOR=<num><cr>
```

Parameters:

<code><num></code>	specifies the GPIO to read
--------------------------	----------------------------

Result:

```
AT-S.Value:<num>:<level>:<direction>
```

<num>	Specifies the number of GPIO read
<level>	0 (low) or 1 (high)
<direction>	0 (output pullup) or 1 (input)

6.17 AT+S.GPIOW

AT+S.GPIOW is used to set the value of a previously-configured output GPIO.

Usage:

```
AT+S.GPIOW=<num>,<level><cr>
```

Parameters:

<num>	specifies the GPIO to be set
<level>	specifies one possible value(0 1) for the specified GPIO.

6.18 AT+S.DAC

The DAC command enables DAC on GPIO15.

Usage:

```
AT+S.DAC=<value><cr>
```

Parameters:

<value>	must be set in mV (between 1 and 3300). The value=0 disables DAC on GPIO15
---------	--

6.19 AT+S.ADC

AT+S.ADC returns ADC value on the selected GPIO. The value range is between 0 and 3300 mV with a measurement accuracy of 10 mV.

Usage:

```
AT+S.ADC=<num><cr>
```

Parameters:

<num>	specifies the GPIO to be used for conversion. Available GPIOs are 0, 1 and 16
-------	---

Result:

AT-S.Value:<value>

<value>

Specifies the ADC value

6.20 AT+S.PWM

The PWM command enables PWM on the selected GPIO, with a specified frequency and duty-cycle.

Usage:

AT+S.PWM=<num>,<frequency>[,<duty_cycle>]<cr>

Parameters:

<num>

specifies the GPIO to be used for PWM. Available GPIOs are 2 and 4

<frequency>

value between 1 and 10 kHz. The value=0 disables PWM

<duty_cycle>

default: 50%. The value is in the 0 - 100 range.

6.21 AT+S.TIME

Command to get or set the time (date, time)

Usage:

1) AT+S.TIME<cr>

returns the current date in the format "AT-S.Date:yy.mm.dd:nn" and the current time in the format "AT-S.Time:hh:mm:ss". The time refers to UTC format and must be expressed as the time in seconds since 1970-Jan-01.

2) AT+S.TIME=<time>

sets the time as specified by the parameter

Parameters:

<time>

value to set the time. The time refers to UTC format and it must be expressed in seconds since 1970-Jan-01.

Result:

AT-S.Date:<yy>.<mo>.<dd>:<day>

AT-S.Time:<hh>.<mi>.<ss>

<yy>

Specifies the year

<mo>	Specifies the month
<dd>	Specifies the day
<day>	Specifies the year of the week
<hh>	Specifies the hours
<mi>	Specifies the minutes
<ss>	Specifies the seconds

6.22 AT+S.RANDOM

Command that provides a random number generated by the peripheral integrated in the STM32.

Usage:

```
AT+S.RANDOM<cr>
```

Parameters:

None

Result:

```
AT-S.Number:<value>
```

<value> Specifies the 32-bit random number

6.23 AT+S.FSC

This command has effect in the RAM memory volume and external SD card volume. The command creates a file in the selected volume or appends the data following the command in case the file already exists. The space available in the file system in RAM can be set using ramdisk_memsize configuration variable. Minimum size is 2 Kb, resulting in maximum 2 files.

Usage:

```
AT+S.FSC=<filename>,<datalen><cr>{data}
```

Parameters:

<filename> name of the file. Max size is 64 bytes

<datalen> amount of space in bytes to allocate for the file

6.24 AT+S.FSD

The command has effect in the RAM memory volume and external SD card volume. The command deletes an existing file.

Usage:

```
AT+S.FSD=<filename><cr>
```

Parameters:

<filename> name of the file to be deleted

6.25 AT+S.FSR

The command has effect in the RAM memory volume and external SD card volume. The command renames an existing file.

Usage:

```
AT+S.FSR=<old_filename>,<new_filename><cr>
```

Parameters:

<old_filename> filename to be renamed
<new_filename> new file name

6.26 AT+S.FSL

This command lists the existing filenames together with their prefix that indicates where they are stored and the size.

X → External Flash	(Volume ID:0)
E → User Flash (stored at STM32F439 address 0x08110000)	(Volume ID:1)
D → RAM	(Volume ID:2)
I → Application Flash (stored at STM32F439 address 0x08100000)	(Volume ID:3)

Note that Volume ID 3, Application Flash, when protected (app_fs status variable set to 2) does not show content files.

Usage:

- 1) AT+S.FSL<cr> print the list of the files on the std output
- 2) AT+S.FSL=[<output_filename>] print the list of the files in the specified name

Parameters:

<output_filename>

Default:2:/dir.txt. When this option is specified, the output of the command is saved in the named filename

Result:

AT-S.File:<flag>\t<len>\t<name>

<flag>

X (External Flash) or E (User Flash) or D (RAM) or I (Application Flash)

<len>

Specifies the file length

<name>

Specifies the file name

6.27 AT+S.FSP

This command prints the content of the specified file starting from the offset and for the specified length.

Usage:

AT+S.FSP=<filename>,[<offset>],[<len>]<cr>

Note that Volume ID 1, Application Flash, when protected (app_fs status variable set to 2) does not allow print on selected file.

Parameters:

<filename>

name of the file to be printed

<offset>

Default Value:0; indicates the byte from where the file is printed

<len>

Default Value: Filesize-Offset; indicates the number of bytes that are printed

6.28 AT+S.FSM

The command is used to mount the selected volume.

Usage:

AT+S.FSM=[<volume>]<cr>

Parameters:

<volume> Default:0; Indicates the memory volume

6.29 AT+S.FSU

The command is used to umount/erase the user memory volumes.

Usage:

AT+S.FSU=[<volume>],[<erase>]<cr>

Parameters:

<volume> Default:0; Indicates the memory volume.
 <erase> Default:0; when"1", the specified volume is fully erased

6.30 AT+S.HASH

The command is used to compute a message digest of a given file.

Usage:

```
AT+S.HASH=[<function>],<filename><cr>
```

Parameters:

<function> Default:0; Indicates the selected hash function. Possible values are 0: SHA1; 1: SHA224; 2: SHA256; 3: MD5
 <filename> filename to be used

Result:

```
AT-S.SHA1:<digest> or
AT-S.SHA224:<digest> or
AT-S.SHA256:<digest> or
AT-S.MD5:<digest>
<digest> Specifies the digest of given file
```

6.31 AT+S.WPAECERT

To manage WPA certificates in the module Flash memory.

Usage:

```
AT+S.WPAECERT=content,<option><cr> to list or to remove certificates within the Flash
AT+S.WPAECERT=<kind>,<size><cr>{data} to load certificates/key within the module memory
```

Parameters:

<option> When the value is equal to 1, the command lists the certificates and key stored in the Flash memory. When the value is equal to 2 the command removes certificates and keys stored in the Flash.

<kind>

Possible values are as follows:

- Ca → {data} correspond to the RADIUS CA
- Cert → {data} correspond to the SPWF04S certificate
- Key → {data} correspond to the SPWF04S key

<size>

Data size in bytes. Data can be transferred in PEM (textual) or in DER (binary) format.

6.32 AT+S.TLSCERT

To Manage TLS certificates in the Module Memory. Note that if Flash is empty, the TLS layer will look for files in the filesystem with the default names of “tls.cert” and “tls.key” for client certificate and key, while CA certificates need filenames corresponding to their Subject Key Identifier (e.g.: “C07A98688D89FBAB05640C117DAA7D65B8CACC4E.ca”). Note also that depending on the type of certificate format loaded (DER or PEM), the subject key identifier is automatically found by the module itself. The “auth” parameter is only required when loading PEM format.

Usage:

```
AT+S.TLSCERT=content,<option><cr>
```

```
AT+S.TLSCERT=<kind>,<size><cr>{data}
```

Parameters:

<option>

When the value is equal to 1, the command lists the certificates and key stored in the Flash memory. When the value is equal to 2, the command removes the certificates and keys stored in the Flash.

Possible values are as follows:

- Ca → {data} correspond to the Peer CA
- Cert → {data} correspond to the SPWF04S certificate
- Key → {data} correspond to the SPWF04S key
- Auth → {data} peer’s CA Authority Key ID

<kind>

Data can be transferred in PEM (textual) or in DER (binary) format.

<size>

6.33 AT+S.WPS

Initiate a WPS exchange.

Usage:

```
AT+S.WPS=<mode><cr>
```

Parameters:

<mode>

mode=0: emulates the push button as defined by the WPS standard

mode=1: executes WPS PIN mode using the factory PIN of the device (stored in the configuration variable wifi_wps_pin)

mode=2: executes WPS PIN mode using a random generated PIN

Result:

AT-S.Generated user PIN:<pin> or
AT-S.Generated random PIN:<pin>

<pin> Specifies the 8-digit pin used for WPS exchange

6.34 AT+S.WIFI

AT+S.WIFI allows the radio to be enabled or disabled at run-time. Please note that the configuration variable "wifi_mode" controls the state of the radio at power-up.

Usage:

AT+S.WIFI=<action><cr>

Parameters:

<action> can assume the values: 0: radio is off, 1: radio is on

6.35 AT+S.SCAN

AT+S.SCAN performs an immediate scan for available networks. The output reports the BSSID, SSID, the network channel, signal strength (RSSI), AP capabilities and 802.11 options included security.

Figure 6. AP capabilities list

```

▼ Capabilities Information: 0x0001
.....1 = ESS capabilities: Transmitter is an AP
.....0. = IBSS status: Transmitter belongs to a BSS
....00.. = CFP participation capabilities: No point coordinator at AP (0x0000)
.....0.... = Privacy: AP/STA cannot support WEP
.....0.... = Short Preamble: Short preamble not allowed
.....0.... = PBCC: PBCC modulation not allowed
.....0.... = Channel Agility: Channel agility not in use
.....0.... = Spectrum Management: dot11SpectrumManagementRequired FALSE
....0.... = Short Slot Time: Short slot time not in use
....0.... = Automatic Power Save Delivery: apsd not implemented
..0.... = DSSS-OFDM: DSSS-OFDM modulation not allowed
..0.... = Delayed Block Ack: delayed block ack not implemented
0.... = Immediate Block Ack: immediate block ack not implemented
  
```

Usage:

AT+S.SCAN=<filter>, [<filename>]<cr>

Parameters:

<filter>	Range of possible values is: d → no filter, s → filter on ssid, m → filter on the mac
<filename>	Default:std output. When specified, the output of the command is saved in the <filename> file.

6.36 AT+S.SSIDTXT

AT+S.SSIDTXT allows to get/set the current value of the variables wifi_ssid and wifi_ssid_len as text strings

Usage:

AT+S.SSIDTXT<cr>	get the value of the variable wifi_ssid.
AT+S.SSIDTXT=<ssidtxt><cr>	set the value of the variables wifi_ssid and wifi_ssid_len

Parameters:

<ssidtxt>	SSID in textual format
-----------	------------------------

Result:

AT-S.Network:<SSID>	
<SSID>	Specifies the SSID of current configured network

6.37 AT+S.PING

Send a single ICMP ECHO request to a specified remote host. When IPv6 is enabled, every network request for name resolution will use IPv6 at the beginning. This means that WIND:24:IPv6 must be waited when ip_use_v6.

Usage:

AT+S.PING=[<counter>],[<size>],<hostname><cr>

Parameters:

<counter>	Default value:1. Number of echo requests to send
<size>	Default value:56 bytes. Highest size of the echo packet. Every sent, or incoming, request will be truncated
<hostname>	Remote Host. DNS resolvable name or IP address

6.38 AT+S.SOCKON

To open a socket client. Up to 8 socket clients can be set simultaneously on the device. The command returns the identifier to be used for operations on the socket.

Usage:

```
AT+S.SOCKON=<hostname>,<port>,<NULL>,<kind><cr>
```

Parameters:

<hostname>

Remote Server. DNS resolvable name or IP address

<port>

TCP/UDP socket port

This parameter can assume the values:

- t → tcp
- u → udp
- s → TLS socket using <Hostname> as domain name.
- TLS Server Domain Name → Common name of the server (URL or the CN field reported into server certificate) for TLS socket

<kind>

Result:

```
AT-S.On:<IP>:<id>
```

<IP>

Specifies the server IP address

<id>

Specifies the socket client identifier

6.39 AT+S.SOCKQ

To query a socket client for pending data. The command returns the number of bytes that are waiting on the socket.

Usage:

```
AT+S.SOCKQ=<id><cr>
```

Parameters:

<id>

Socket Client ID

Result:

AT-S.Query:<len>

<len>

Specifies the number of bytes in socket client buffer

6.40 AT+S.SOCKC

To close a socket client.

Usage:

AT+S.SOCKC=<id><cr>

Parameters:

<id>

Socket Client ID

Note: When a socket client receives an indication about socket server gone (only for TCP/TLS sockets, WIND:58), the socket resource is not automatically cleared. Moreover, flushing pending data (using the AT+S.SOCKR command) is mandatory before closing the socket connection (AT+S.SOCKC). If the buffer is not empty, the "ERROR:Pending data" is raised.

6.41 AT+S.SOCKW

To write data to a socket client. The host is expected to send <length> characters of data after the end of the command.

Usage:

AT+S.SOCKW=<id>,<length><cr>{data}

Parameters:

<id>

Socket Client ID

<length>

Data length to send (in bytes)

6.42 AT+S.SOCKR

To read data from a socket client.

Usage:

AT+S.SOCKR=<id>,[<length>]<cr>

Parameters:

<id>	Socket Client ID
<length>	Default:0. Length (in bytes) of the buffer to read. The value 0 indicates to read the full buffer

6.43 AT+S.SOCKL

To list opened socket clients.

Usage:

```
AT+S.SOCKL<cr>
```

Parameters:

None

Result:

```
AT-S.List::<id>:<connected>:<kind>:<len>:<IP>:<port>
```

<id>	Specifies the socket client identifier
<connected>	Specifies whether socket client is connected to socket server
<kind>	Specifies the kind of socket client
<len>	Specifies the number of bytes in socket client buffer
<IP>	Specifies the server IP address
<port>	Specifies the client port

6.44 AT+S.SOCKDON

To open a socket server. The device can manage up to 2 socket servers each supporting 8 socket clients. The command returns the server socket ID to be used in the related commands.

Usage:

```
AT+S.SOCKDON=<port>,<kind><cr>
```

Parameters:

<port>	socket port
<kind>	specifies the kind of socket as one of the following: <ul style="list-style-type: none"> • t → tcp • u → udp • s1 → TLS socket with one-way authentication • s2 → TLS socket with mutual authentication

Result:

AT-S.On:<id>

<id>

Specifies the socket server identifier

6.45 AT+S.SOCKDQ

To query a socket server for pending data.

Usage:

AT+S.SOCKDQ=<sid>,<cid><cr>

Parameters:

<sid>

socket server identifier

<cid>

socket client identifier

Result:

AT-S.Query:<len>

<len>

Specifies the number of bytes in client buffer

6.46 AT+S.SOCKDC

To close a socket server or to disconnect a client.

Usage:

AT+S.SOCKDC=<sid>

to close the specified socket server (and disconnect all clients)

AT+S.SOCKDC=<sid>[,<cid>]

to disconnect the specified client, if client_id is given. If not, all clients are disconnected, and server is closed

Parameters:

<sid>

socket server identifier

<cid>

socket client identifier

Note: Flushing pending data (using the AT+S.SOCKDR command) is mandatory before closing the socket connection (AT+S.SOCKDC). If the buffer is not empty, the “ERROR: Pending data” is raised.

6.47 AT+S.SOCKDW

To write data to a socket server.

Usage:

```
AT+S.SOCKDW=<sid>,<cid>,<len><cr>{data}
```

Parameters:

<sid>	socket server identifier
<cid>	socket client identifier
<len>	length (in bytes) of the buffer to write that is sent after the command.

6.48 AT+S.SOCKDR

To read data from a socket server.

Usage:

```
AT+S.SOCKDR=<sid>,<cid>,[<len>]<cr>
```

Parameters:

<sid>	socket server identifier
<cid>	socket client identifier
<len>	Default:0. length (in bytes) of the buffer to read. The value=0 indicates to read the entire buffer.

6.49 AT+S.SOCKDL

To list the bound socket client.

Usage:

```
AT+S.SOCKDL
```

```
AT+S.SOCKDL=<sid><cr>
```

to list bound clients on all servers

Parameters:

<sid>	socket server identifier
-------	--------------------------

Result:

```
AT-S.List:<id>:<cid>:<connected>:<kind>:<len>:<IP>:<port>
```

<id>	Specifies the socket server identifier
<cid>	Specifies the socket client identifier
<connected>	Specifies whether socket client is connected to socket server
<kind>	Specifies the kind of socket client
<len>	Specifies the number of bytes in client buffer
<IP>	Specifies the client IP address
<port>	Specifies the client port

6.50 AT+S.TFTPGET

The stack implements the TFTP client protocol to transfer files on a UDP port. The command performs a request to a specified TFTP server.

Usage:

```
AT+S.TFTPGET=<hostname>,[<port>],<filename>,<local_filename><cr>
```

Parameters:

<hostname>	DNS resolvable name or IP address of the TFTP remote server
<port>	Default:69. Socket UDP port
<filename>	filename to get from the remote host. It contains the complete path
<local_filename>	Default:2:<Filename>. Filename used locally

6.51 AT+S.TFTPPUT

The stack implements the TFTP client protocol to transfer files on a UDP port. The command performs a request to a specified TFTP server.

Usage:

```
AT+S.TFTPPUT=<hostname>,[<port>],<local_filename><cr>
```

Parameters:

<hostname>	DNS resolvable name or IP address of the TFTP remote server
<port>	Default: 69. Socket UDP port
<local_Filename>	filename to send to the remote host

6.52 AT+S.SMTP

The stack implements the protocol SMTP to send an email.

Usage:

```
AT+S.SMTP=<hostname>, [<port>], [<TLS>], [<username>], [<passwd>],
[<ID>], <address>, <to>, <NULL>, <NULL>, <subject>, <NULL>, <len><cr>{data}
```

Parameters:

<code><hostname></code>	DNS resolvable Name or IP address of the remote host
<code><port></code>	Default is 25 (if TLS=0) or 465 (if TLS>0). Server port
<code><TLS></code>	Default:unsecured TLS Security option. 0 → unsecured, 5 → SMTPS on port 465 if available, otherwise SMTP + STARTTLS if available, otherwise no security, 8 → SMTP + STARTTLS if available, otherwise the mail is not sent, 9 → SMTPS on port 465 if available, otherwise SMTP + STARTTLS if available, otherwise the mail is not sent.
<code><username></code>	User of the SMTP server
<code><passwd></code>	Password of the SMTP server
<code><ID></code>	Default: nv_model used during Helo
<code><address></code>	Email address on the SMTP server
<code><to></code>	Email recipients. Multiple emails are separated by a semicolon A recipient can be just an email address, or be in the extended format consisting of a name followed by a '<', followed by the email address and terminated by a '>' (e.g. "Nick <nick@name.xy>")
<code><subject></code>	Email Subject. String message
<code><len></code>	Length of the Body message

6.53 AT+S.HTTPGET

To perform a single http get request to the named host and path.

Usage:

```
AT+S.HTTPGET=<hostname>, [<path&queryopts>], [<port>], [<TLS>], [<username>],
[<passwd>], [<in_filename>], [<out_filename>]<cr>
```

Parameters:

<code><hostname></code>	DNS resolvable Name or IP address
<code><path&queryopts></code>	Default:/index.html. document path & optional query arguments
<code><port></code>	Default 80 (if TLS=0) or 443 (if TLS>0)

<TLS>	Default: 0. Values range: 0 → unsecured; 1 → autodetect; 2 → TLS
<username>	Default: none
<passwd>	Default: none
<in_filename>	Default: none. Custom http requests
<out_filename>	Default: Console. When specified the return data are saved in a file

6.54 AT+S.HTTPPOST

To perform a post of the specified file to a remote host.

Usage:

```
AT+S.HTTPPOST=<hostname>, [<path&queryopts>], [<port>], [<TLS>], [<username>],
[<passwd>], [<in_filename>], [<out_filename>]<cr>
```

Parameters:

<hostname>	DNS resolvable Name or IP address
<path&queryopts>	Default:/index.html. document path & optional query arguments
<port>	Default 80 (if TLS=0) or 443 (if TLS>0)
<TLS>	Default: 0. Values range: 0 → unsecured; 1 → autodetect; 2 → TLS
<username>	Default: none
<passwd>	Default: none
<in_filename>	Default: none. Console. When specified the return data are saved in a file
<out_filename>	Default: none. Filename to transfer to the server. Please refer to following table the right association between file extension and HTTP Content-Type.

Table 5. Association between file extension and HTTP content-type

File extension	Content-type
html	text/html
fhtml	text/html
css	text/css
txt	text/plain
xml	text/xml
xls	text/xls
gif	image/gif
jpg	image/jpg
bmp	image/bmp

File extension	Content-type
png	image/png
ico	image/x-icon
class	application/x-java-applet
swf	application/x-shockwave-flash
json	application/json
woff	application/font-woff
form	application/x-www-form-urlencoded
unknown extension	application/x-raw-stuff

6.55 AT+S.INPUTSSI

Fill buffer for raw text input SSI <!--[06|Input|index|-->. See AN4965 for details on the use of the SSI.

Usage:

```
AT+S.INPUTSSI=<length><cr>{data}
```

Parameters:

<length>

Length of the data to save in the buffer. The length=0 cleans the buffer.

Note: {data} used to fill the buffer must be properly set. The first byte is used as a token splitter; so use this special character to fill the buffer with multiple tokens. Every token can be directly referred remotely by SSI indexes contained inside the HTML page. For example: "hello|world|" will create 2 tokens: "hello" accessed by <!--[06|Input|0|-->, and "world" accessed by <!--[06|Input|1|-->.

6.56 AT+S.MQTTCONN

To open a connection with an MQTT Broker. The command returns a local ID =0, used in the correspondent commands. The device manages one MQTT connection at a time.

Usage:

```
AT+S.MQTTCONN=<hostname>, [<port>], [<path>], [<TLS>], [<username>], [<passwd>],
[<userID>], [<keep_alive>], [<retry>], [<lastWill_QoS>], [<lastWill_topic>],
[<lastWill_message>]<cr>
```

Parameters:

<hostname>

DNS resolvable name or IP address of the MQTT broker

<port>

Default:1883

<path>

Default:/

<TLS>	Default: 0. Values range: 0 → unsecured; 1 → autodetect; 2 → TLS
<username>	Default: none. User Name
<passwd>	Default: none. Passwd
<userID>	Default: nv_model used during MQTT communications
<keep_alive>	Default: 60 seconds
<retry>	Default: 15 seconds
<lastWill_QoS>	Default: 0. Last action to be executed by the broker when the node disappears without a disconnect procedure
<lastWill_topic>	Default: None. Last Will Topic
<lastWill_message>	Default: None. Published on the Last Will Topic

Result:

AT-S.On:<id>:<session>

<id>	Specifies the MQTT client identifier
<session>	0 (new session) or 1 (session restored)

6.57 AT+S.MQTTPUB

To publish a message to an MQTT broker

Usage:

AT+S.MQTTPUB=0,<topic>,[<QoS>],[<retained_flag>],<len><cr>{data}

Parameters:

<topic>	Topic where the message is published
<QoS>	Default: 0. Values Range: 0 → at most once delivery; 1 → at least one delivery; 2 → exactly one delivery
<retained_flag>	Default: 0. Possible values: 0 → do not retain, 1 → retain
<len>	MQTT message length

6.58 AT+S.MQTTDISC

To disconnect from an MQTT broker.

Usage:

AT+S.MQTTDISC=0<cr>

Parameters:

None

6.59 AT+S.MQTTSUB

To subscribe topic to an MQTT broker.

Usage:

```
AT+S.MQTTSUB=0,<topic>,[<QoS>]<cr>
```

Parameters:

<topic>

Topic where the node subscribes

<QoS>

Default:0. Values Range: 0 → at most once delivery; 1 → at least one delivery; 2 → exactly one delivery

6.60 AT+S.MQTTUNSUB

To unsubscribe topic from an MQTT broker.

Usage:

```
AT+S.MQTTUNSUB=0,<topic><cr>
```

Parameters:

<topic>

Topic where the node unsubscribes

6.61 AT+S.WSOCKON

The module supports the usage of two web socket clients. The command returns the ID that is used in the corresponding commands.

The MQTT layer is built on top of web sockets. This means that (when an MQTT broker has been connected through AT+S.MQTTCONN) the total amount of available web sockets decreases to just 1. Note that it is not possible to run another AT+S.WSOCKON to the same web socket server.

Usage:

```
AT+S.WSOCKON=<hostname>,[<port>],[<path>],[<TLS>],[<username>],[<passwd>],[<origin>],[<protocols>],[<extensions>]<cr>
```

Parameters:

<hostname>

DNS resolvable name or IP address of the web socket server

<port>

Default 80 (if TLS=0) or 443 (if TLS>0)

<path>	Default:/
<TLS>	Default: 0. Values range: 0 → unsecured; 1 → autodetect; 2 → TLS
<username>	Default: none. Username on the remote server
<passwd>	Default: none. Password on the remote server
<origin>	Default:none. Header Field Origin
<protocols>	Default:none. Header Field Protocols
<extensions>	Default:none. Header Field Extensions

Result:

AT-S.On:<id>

<id>

Specifies the Web Socket client identifier

6.62

AT+S.WSOCKQ

To query web socket client for pending data.

Usage:

AT+S.WSOCKQ=<id><cr>

Parameters:

<id>

Web socket client identifier

Result:

AT-S.Query:<len>

<len>

Specifies the number of bytes in Web Socket client buffer

6.63

AT+S.WSOCKC

To close a web socket client using a specific status code.

Usage:

AT+S.WSOCKC=<id>,[<status>]<cr>

Parameters:

<id>	Web socket client identifier
<status>	Default:0; 0 → Normal Closure; 1 → Going Away; For a complete list of the status values defined for the web socket, refer to the related standard

Note: When a web socket client receives an indication about web socket server gone (WIND:89), the web socket resource is not automatically cleared. Moreover, flushing pending data (using the AT+S.WSOCKR command) is mandatory before closing the socket connection (AT+S.WSOCKC). If the buffer is not empty, the "ERROR:Pending data" is raised.

6.64 AT+S.WSOCKW

To write data to a web socket.

Usage:

```
AT+S.WSOCKW=<id>,[<last_frame>],[<last_frag>],[<binary>],<len><cr>{data}
```

Parameters:

<id>	Web socket client identifier
<last_frame>	Default:0. 1 → Last frame flag
<last_frag>	Default:0. 1 → Last frag flag
<binary>	Default:0, textual. 1 → Binary flag

6.65 AT+S.WSOCKR

To read data from a web socket client.

Usage:

```
AT+S.WSOCKR=<id>,[<len>]<cr>
```

Parameters:

<id>	Web socket client identifier
<len>	Default 0. 0 value indicates read the full buffer

6.66 AT+S.WSOCKL

To list opened web socket clients.

Usage:

```
AT+S.WSOCKL<cr>
```

Parameters:

None

Result:

AT-S.List:<id>:<connected>:<len>:<port>

<id>	Specifies the Web Socket client identifier
<connected>	Specifies wheter Web Socket client is connected to Web socket server
<len>	Specifies the number of bytes in Web Socket client buffer
<port>	Specifies the local port

7 Technology partners

Table 6. Technology partners

Partner	Device description	Part number
MACRONIX	8-Mbit CMOS Serial Flash memory	MX25L8006E
MACRONIX	64-Mbit CMOS Serial Flash memory	MX25L6433F

8 Variables and values

The following table lists the configuration variables together with their default values. The list of configuration variables is generated by the command AT+S.GCFG.

Table 7. Configuration variables

Variable name	Default value	Type	Description
nv_manuf	STMicroelectronics Inc.	TEXT[32]	Manufacturer ID string
nv_model	SPWF04SA	TEXT[32]	Manufacturer Model String
nv_serial	0517<11222	TEXT[32]	Manufacturer Serial Number
nv_wifi_macaddr	00:80:E1:FA:12:34	HEX[6]	Manufacturer assigned 802.11 MAC Address
standby_time	10	INT	Standby mode time, in seconds. Up to 2exp(32)-1 sec
standby_enabled	0	INT	Enable/disable the standby mode
sleep_enabled	0	INT	Enable/Disable the sleep mode
etf_mode	0	INT	Enable/Disable the Engineering test functions. It is used to control the radio for the certification tests
blink_led	1	INT	Manage led drive GPIO(10). 0=off 1=On
ext_volume	3	INT	Used to manage ext. storage. 0-disabled, 1-SDCARD, 2-SPI, 3-Autodetection
ramdisk_memsize	16	INT	Heap size dedicated to RAM disk in unit of 1024 byte
aes128_key	00:00:00:00:00:00:00:00:00:00:00:00:00:00:00:00	HEX[16]	AES-128 key used to encrypt FOTA image
user_desc	anonymous	TEXT[16]	Password used during remote configuration
python_script	3:/uPython_test.py	TEXT[64]	Specifies the python script to run when GPIO[8] is high at the boot time
python_memsize	32	INT	Heap size dedicated to MicroPython execution in unit of 1024 byte
console_enabled	1	INT	0→SPI; 1→ UART; 2→UART+Python; 3→Python
console_speed	115200	INT	Serial Port Speed: from 9600 to 921600.
console_hwfc	0	INT	Hardware Flow Control. 0=off; 1=on
console_echo	1	INT	Echo command input. 0=off, 1=on
console_errs	2	INT	ERROR:#:string Format. Format Selection. 0→ simple notification 1:→ numbered notification 2→ verbose notification
console_winds	2	INT	WIND:#:string:p Format Selection. 0→ simple notification 1:→ numbered notification 2→ verbose notification
console_verbose	1	INT	Verbose output. 0=off; 1=on, with short OK message; 2=full on
console_repeater	0x21	HEX	Set the console repeater.
console_delimiter	0x2C	HEX	Set the console delimiter.

Variable name	Default value	Type	Description
console_wind_off_low	0x00000000	HEX	Wind 0:31 mask 0xFFFFFFFF are disabled all the 32 Wind indicator
console_wind_off_medium	0x00000000	HEX	Wind 32:63 mask
console_wind_off_high	0x00000000	HEX	Wind 64:95 mask
wifi_tx_msdu_lifetime	0	INT	MSDU lifetime. From 0 to 2 ³² -1 TUs (1 TUs=1024μs). Zero is default (automatic)
wifi_rx_msdu_lifetime	0	INT	MSDU lifetime. From 0 to 2 ³² -1 TUs (1 TUs=1024μs). Zero is default (automatic)
wifi_operational_mode	0x00000011	INT	Allows choosing Doze (11) or quiescent (12) power device modes
wifi_beacon_wakeup	1	INT(sec)	Set the wakeup interval of the WLAN device, from 1 to 255 if wifi_listen_interval = 0; from 1 to 65535 if wifi_listen_interval = 1
wifi_beacon_interval	100	INT	Beaconing interval in MiniAP mode, from 0 to 2 ¹⁶ -1
wifi_listen_interval	0	INT	Define the wakeup mode (0 = sleep up to the beacon_wakeup specified, 1 = sleep at least to the beacon_wakeup specified)
wifi_rts_threshold	3000	INT	Frame size over which RTS/CTS is used. Limit: from 0 to 3000
wifi_ssid	53:54:54:65:73:74:00	HEX[32]	Can be get/set with the command AT +S.SSIDTXT. Desired SSID specified in hex. All 32 octets should be written. Note that wifi_ssid_len must also be set.
wifi_ssid_len	6	INT	Can be set with the command AT +S.SSIDTXT. Length of the actual SSID in the 32 byte buffer
wifi_txfail_thresh	5	INT	Maximum number of lost packets before disassociation
wifi_dtim_period	1	INT	Amount of frames stored for associated powersaving STAs. 0=do not store frames, 1=store 1 frame
wifi_add_tim_ie	0	INT	Whether or not to add the TIM information element in miniAP beacons. 0=do not add, 1=add
wifi_region	1	INT	Setting the scan process used during the command AT+S.SCAN. set the channels allowed for active scan (0 = always passive scan, 1 = active scan only on channels enabled by wifi_chan_activity2 status variable [default], 2 = USA X10 [1-11], 3 = Canada X20 [1-11], 4 = Europe ETSI X30 [1-13], 5 = France X32 [10,11], 6 = Japan X40 [1-13], 7 = Japan X41 [10,11,14])

Variable name	Default value	Type	Description
wifi_ht_mode	1	INT	Enable the 802.11n mode. The 11n data rates must be enabled with the wifi_opr_rate_mask variable (i.e. wifi_opr_rate_mask=3FFF CF to enable all the data rate supported)
wifi_channelnum	1	INT	Channel number to use for MiniAP operation. The user must properly set the channel number to not violate IEEE 802.11 Wi-Fi/WLAN standards.
wifi_opr_rate_mask	0x003FFFCF	INT	BIT0: 1 Mbps BIT1: 2 Mbps BIT2: 5.5 Mbps BIT3: 11 Mbps BIT6: 6 Mbps BIT7: 9 Mbps BIT8: 12 Mbps BIT9: 18 Mbps BIT10: 24 Mbps BIT11: 36 Mbps BIT12: 48 Mbps BIT13: 54 Mbps BIT14: MCS0 (6.5Mbps) BIT15: MCS1 (13Mbps) BIT16: MCS2 (19.5Mbps) BIT17: MCS3 (26Mbps) BIT18: MCS4 (39Mbps) BIT19: MCS5 (52Mbps) BIT20: MCS6 (58.5Mbps) BIT21: MCS7 (65Mbps)
wifi_bas_rate_mask	0x0000000F	INT	Basic data rate mask, 0x0000000f is [1,2,5,5,11]
wifi_mode	1	INT	Radio mode. 0=IDLE 1=STA (Supported Security Modes: OPEN, WEP OpenSystem, WEP SharedKey, WPA/WPA2 - wifi_auth_type must be set to 0, WPA-Enterprise) 2=IBSS (Supported Security Modes: OPEN, WEP OpenSystem, WEP SharedKey) 3=MiniAP (Supported Security Modes: OPEN, WEP OpenSystem, WPA/WPA2 - wifi_auth_type must be set to 0, Supported Classes: b,g) *
wifi_auth_type	0	INT	Authentication type used in STA, IBSS and MiniAP mode: 0=OpenSystem, 1=SharedKey
wifi_atim_window	0	INT	Reserved
wifi_powersave	0	INT	Allows choosing between Active (0), PS (1) or Fast-PS (2)
wifi_tx_power	18	INT	Transmit power [from 0 to 18], in dBm

Variable name	Default value	Type	Description
wifi_rssi_thresh	0	INT	Low signal strength threshold
wifi_rssi_hyst	0	INT	Amount of change in RSSI to trigger signal state change
wifi_ap_idle_timeout	120	INT	Seconds of inactivity to trigger disassociate of the client
wifi_beacon_loss_thresh	10	INT	Number of consecutive loss beacon to detect the AP disassociation (0=network lost not notified, from 1 to 200)
wifi_priv_mode	0	INT	Privacy Mode: 0=none, 1=WEP, 2=WPA-Personal (TKIP/AES) or WPA2- Personal (TKIP/AES) - wifi_auth_type must be set to 0,3=WPA2-Enterprise
wifi_wep_keys[0]	00:00:00:00:00:00:00:00:00:00:00:00:00:00:00:00	HEX[16]	WEP key buffer
wifi_wep_keys[1]	00:00:00:00:00:00:00:00:00:00:00:00:00:00:00:00	HEX[16]	WEP key buffer
wifi_wep_keys[2]	00:00:00:00:00:00:00:00:00:00:00:00:00:00:00:00	HEX[16]	WEP key buffer
wifi_wep_keys[3]	00:00:00:00:00:00:00:00:00:00:00:00:00:00:00:00	HEX[16]	WEP key buffer
wifi_wep_key_lens	00:00:00:00	HEX[4]	Four octets specifying the length of the actual key data in each WEP key buffer
wifi_wep_default_key	0	INT	WEP key index
wifi_wpa_psk_raw	00:00	HEX[32]	Pre-calculated PSK key
wifi_wpa_psk_text		TEXT[64]	WPA(2) PSK passphrase, if set the actual PSK will be generated from this. Used in STA, IBSS and MiniAP.
wifi_eap_identity	identity	TEXT[32]	specifies the username by which the SPWF04S authenticates itself to the network
wifi_eap_anon_identity	anonymous@identity.org	TEXT[32]	specifies the anonymous identity string used in the first phase of most of the EAP authentication methods
wifi_eap_passwd	password	TEXT[32]	specifies the password by which the SPWF04S authenticates itself to the network.
wifi_eap_type	0	INT	EAP authentication method. 0=EAP-TLS; 1=TTLS-MD5, 2=TTLS-MSCHAPv2, 3=PEAP-MD5,4=PEAP-MSCHAPv2
wifi_eap_skip_datechecks	0	INT	RADIUS certificate date validity check. 0→enabled; 1→disabled
wifi_wps_walk_time	120	INT	Button push time window length

Variable name	Default value	Type	Description
wifi_wps_pin	1234567	INT	Wps pin
ip_sock_memsize	1	INT	Heap size dedicated to every socket connection in unit of 1500 byte
ip_sock_threshold	0	INT	Percentage of ip_sock_memsize used to allow +WIND:55 and +WIND:88 indications
ip_dhcp_lease_time	120	INT	IP address renew of the peers in MiniAP mode (default: 120 sec)
ip_macfilter	00:00:00:00:00:00	HEX[6]	Mask for filtering of mac address during the association process. The IP is not released to not selected mac address
ip_num_clients	5	INT	Number of allowed clients. IP not released beyond this number
ip_allow_port_scans	1	INT	Scan from remote port enabler. 0=do not allow; 1=allow
ip_use_v6	1	INT	IPv6 Enable.
ip_use_dhcpd	1	INT	DHCP Server Enable. To be Used in MiniAP mode. 0=off;1=on
ip_use_httpd	1	INT	HTTP Enable. 0=off;1=on
ip_use_tftpd	1	INT	TFTP Enable. 0=off;1=on
ip_use_dhcpc	2	INT	Dhcp Client. 0→off; 1→on; 2→ autoip
ip_hostname	iwm-FA-12-34	TEXT[32]	IP local hostname
ip_apdomainname	captiveportal.net	TEXT[32]	Domain name in Mini AP mode. If the AP domain name is not quickly opened, it's suggested to turn off an eventual proxy server (check the connection settings of the device or the browser preferences). Please be sure to provide a standard extension (.net, .com, etc.)
ip_apredirect	firstset.html	TEXT[16]	Default homepage opening the ip_apdomainname in miniAP
ip_ipaddr	192.168.0.50	IP	IP address for static usage (DHCP off)
ip_netmask	255.255.255.0	IP	IP netmask for static usage (DHCP off)
ip_gw	192.168.0.1	IP	IP default gateway for static usage (DHCP off)
ip_dns1	208.67.222.222	IP	IP Primary DNS server for static usage (DHCP off)
ip_dns2	208.67.220.220	IP	IP Secondary DNS server for static usage (DHCP off)
ip_local	0:0:0:0:0:0:0	IPv6	IPv6 unique local address
ip_dns1v6	0:0:0:0:0:0:0	IPv6	IPv6 Primary DNS server for static usage (DHCP off)
ip_dns2v6	0:0:0:0:0:0:0	IPv6	IPv6 Secondary DNS server for static usage (DHCP off)
ip_dhcp_timeout	20	INT	DHCP client timeout, in seconds
ip_ntp_server1	ptbtime1.ptb.de	TEXT[32]	Primary NTP server (IPv4)
ip_ntp_server2	ntp0.ipv6.fau.de	TEXT[32]	Secondary NTP server (IPv4 when ip_use_v6=0, IPv6 when ip_use_v6=1)

Variable name	Default value	Type	Description
ip_ntp_refresh	3600	INT	Refresh time interval
ip_ntp_startup	1	INT	NTP enabler at the startup. 0→off; 1→on
ip_mdns_domain_name	SPWF04S-Default	TEXT[32]	MDNS domain name
ip_mdns_device_name_ttl	120	INT	MDN Time To Live
ip_mdns_services_name	SPWF04S-WebSrv SPWF04S-TFTPSrv	TEXT[64]	Services list separated by space (max two services)
ip_mdns_services_prot	_http._tcp._ftp._udp	TEXT[64]	Services protocol list separated by space
ip_mdns_services_keys	dev1 dev2	TEXT[32]	Services keys list separated by space
ip_mdns_services_vals	number1 number2	TEXT[32]	Services values list separated by space
ip_mdns_services_port	80 69	INT	Services ports list separated by space
ip_mdns_services_ttl	120 60	INT	Services ttl list separated by space
ip_mdns_startup	01:01	HEX[2]	Services enabler at the startup separated by space

The following table lists the status variables together with their associated values. The list of status variables is generated by the command AT+S.STS.

Table 8. Status variables

Status variable	Value	Note
build	170216-fd39c59-SPWF04S	SW Build Version
fw_version	1.0.0	SW Major Version
boot_version	1.0	Boot Version
var_version	1	Variable List version
free_heap	55200	Current free heap space
min_heap	52576	Minimum free heap space thus far
system_time	1467386876	Current Time in UTC format in sec
system_uptime	1780	System Running Time in sec
system_sleeptime	0	System Sleeping time in seconds
reset_reason	2	H/W reported reason for last reset 0 = POWER_ON 1 = WATCHDOG 2 = SOFT RESET 3 = LOW POWER 4 = HW RESET
startup	0	Failure reasons at the boot time (see wind:7 description)
random_number	3725839442	Random Number generated by the random generator with the AT+S.RANDOM command
gpio_enable	0x0000	Interrupt-enabled GPIO bitmask, expressed in HEX
app_fs	1	App Flash. 0 → FS not mounted; 1→ mounted; 2 → mounted and protected. Application Filesystem can be protected through " __LOCKED__ " file insert.
user_fs	0	User Flash. 0→ FS not mounted; 1→ mounted
extvol_fs	0	Ext. Storage. 0 → FS not mounted; 1 → mounted
nv_power_cycles	5	Number of executed power-on

Status variable	Value	Note
nv_wdog_resets	0	Number of reset due to watchdog
nv_reset_cycles	43	Number of reset cycles
wifi_state	10	0= Hardware power up 1=Hardware failure 2=Radio task terminated by user 3=Radio idle 4=Scan in progress 5=Scan complete 6=Join in progress 7=Joined 8=Access point started 9=802.11 handshake complete 10=Ready to transmit data (i.e. "Link Up")
wifi_own_macaddr	00:80:E1:FA:12:34	Mac address
wifi_bssid	00:18:F8:3C:D9:18	BSSID of current association
wifi_aid	0	Association ID of current association
wifi_channelnum	11	Current radio channel number
wifi_sup_rate_mask	0x003FFFCF	Radio: supported data rate mask
wifi_bas_rate_mask	0x0000000F	AP reported: basic data rate mask
wifi_chan_activity	0x00003FFF	Channels where we are allowed to transmit. Channel mask. i.e. 0x00003FFF → from channel 0 to channel 13
wifi_max_tx_power	18	max allowed transmit power for the defined regdomain
wifi_gf_mode	0	Greenfield (high throughput) mode
wifi_reg_country	IT	Current regulatory domain
wifi_dtim_period	1	AP reported DTIM period (used in STA mode)
wifi_num_assoc	1	Number of the client associated to the module
ip_from_AutoIP	0	Indicates if the IP derives from AutoIP
ip_ipaddr	192.168.121.184	Current IP address
ip_netmask	255.255.252.0	Current IP netmask
ip_gw	192.168.123.20	Current IP default gateway
ip_dns1	192.168.123.20	Current IP Primary DNS server
ip_dns2	192.168.123.20	Current IP Secondary DNS server
ip_linklocal	fe80:0:0:0:280:e1ff:fefa:1234	Current IPv6 linklocal
ip_local	fec0:0:0:0:280:e1ff:fefa:1234	Current IPv6 local
ip_dns1v6	0:0:0:0:0:0:0	Current IPv6 Primary DNS Server
ip_dns2v6	0:0:0:0:0:0:0	Current IPv6 Secondary DNS server

The following table lists the peer variables together with their associated values. The list of peer variables is generated by the command AT+S.PEERS.

Table 9. Peer variables

Peers variables	Value	Note
<i>AT-S.Var:n.<var> where n:0=mode connected to STA; n between 1 to 5=id of the connected client</i>		
link_id	0	Identifier of the client
state	4	0 = Hardware Power Up 1 = HW link initialization 2 = Client Link identifier allocated 3 = Authenticated 4 = Associated 5 = Peer lost beacons 6 = Peer in power save state
addr	02:62:1F:51:8F:0B	MAC address of the client
last_rx	14	Timestamp of last received packet
last_tx	14	Timestamp of last transmitted packet
rx_drops	0	Count of frames dropped during reception
tx_drops	0	Count of frames dropped during transmission
rx_pkts	22	Count of received frames
tx_pkts	24	Count of transmitted frames
tx_errs	0	Count of errors detected during frame transmit
rate_mask	0x00003FCF	AP reported Operational data rate mask
cur_rate_idx	3	Most significant byte of the rate_mask
cur_rate_ok	3	Counter to perform rate step up
cur_rate_fail	0	Counter to perform rate step down
tx_consec_fail	0	Counter to perform disassociation
rx_seqnum	0x000031F0	Sequence number of last RX directed frame
rx_seqnum_mc	0x00002780	Sequence number of last RX multicast frame
rx_rssi	-51	Signal strength of last received packet
rx_rateidx	13	Rate index of last received packet
setprot	3	Bitmask to indicate protection for TX (bit 1) and/or RX (bit 0) IEEE 802.11 frames
listen_interval	0	AP reported listen interval
capinfo	0x00000411	Information about the AP capabilities

9 Synchronous errors and WIND messages

Synchronous errors

The following tables list the synchronous errors, each specified with its ID. The tables also show the errors that are specific to an HTTP client connection. They are characterized by the prefix AT-S.

Table 10. AT-S.ERROR:=ERROR ID= =ERROR String=

ERROR ID	ERROR string
1	"Command not found"
2	"Missing argument(s)"
3	Reserved
4	"Variable not found"
5	Reserved
6	"Too many argument(s)"
7	"Invalid argument(s)"
8	"Invalid value"
9	Reserved
10	Reserved
11	Reserved
12	Reserved
13	Reserved
14	Reserved
15	Reserved
16	"Cannot switch to Python shell"
17	"Radio enabled"
18	"Radio not running"
19	"Direction must be 'in' or 'out'"
20	"Invalid GPIO Num (0-15)"
21	"Cannot use GPIO6 when sleep_enabled"
22	"Cannot use interrupt. Reserved for WPS feature"
23	"Cannot use GPIO10 when blink_led"
24	"Cannot use when SPI"
25	"Interrupt line already set"
26	"Output voltage not allowed"
27	"Frequency not supported"
28	"Duty cycle not supported"
29	"PWM not running"
30	Reserved
31	Reserved
32	"Argument exceeds allowed size"
33	"Argument evaluated to zero"

ERROR ID	ERROR string
34	Reserved
35	Reserved
36	Reserved
37	Reserved
38	Reserved
39	"PIN needs to be 7 digits"
40	"Scan in Progress"
41	"Scan Failed"
42	"Wait for Hardware Busy"
43	"Wait for Hardware Starting"
44	"Wait for Connection Up"
45	"Unable to complete PWM setting"
46	"ADC conversion failed"
47	Reserved
48	Reserved
49	Reserved
50	"Unable to access filesystem"
51	"Unable to open file"
52	"Unable to seek file"
53	"Unable to read file"
54	"Unable to close file"
55	"Unable to rename file"
56	"Unable to delete file"
57	"Unable to open directory"
58	"Unable to read directory"
59	"Unable to (un)mount volume"
60	"IP not ready to send"
61	"Cannot renew IP address"
62	"Failed to renew IP address"
63	"DNS busy"
64	"DNS start failed"
65	"DNS address failure"
66	"Cannot update Date Time"
67	"WPS only allowed on STA mode"
68	Reserved
69	Reserved
70	Reserved
71	Closing socket
72	"Closed socket"
73	"Port already opened"

ERROR ID	ERROR string
74	"Failed to open socket"
75	"Too many sockets"
76	"Illegal Socket ID"
77	"Pending data"
78	"Socket not connected"
79	"Write failed"
80	"No valid HTTP Client Instance ID"
81	"HTTP Client busy"
82	"Failed to release HTTP Client Instance"
83	Reserved
84	Reserved
85	Reserved
86	Reserved
87	Reserved
88	Reserved
89	Reserved
90	Reserved
91	"Low Memory"
92	Reserved
93	Reserved
94	Reserved
95	Reserved
96	Reserved
97	Reserved
98	Reserved
99	"Scan Aborted"
100	"Failed to read flash"
101	"Failed to write flash"
102	Reserved
103	Reserved
104	Reserved
105	Reserved
106	Reserved
107	Reserved
108	Reserved
109	Reserved
110	Reserved
111	"Request failed"
112	Reserved
113	Reserved

ERROR ID	ERROR string
114	Reserved
115	Reserved
116	Reserved
117	Reserved
118	Reserved
119	Reserved

Table 11. AT-S.WebSocket Client Error:=Error ID=

ERROR ID	Description
0	Connection Refused
1	TCP error (TimeoutConn TimeoutData Disconnected Send NoTcpConnection)
2	TLS Connection Error
3	Server Resolve Error
4	HTTP Error (Parser Generator ProtocolSwitch)
5	HTTP Timeout

Table 12. AT-S.Http Client Error:=Error ID=

ERROR ID	Description
0	Error while resolving Hostname
1	Timeout while TCP-Connect (TCP-Syn)
2	Error or timeout while TCP-Connect
3	HTTP Client refused connecting to server
4	Timeout while receiving TCP data
5	Received unexpected TCP-Disconnect while sending
6	Error while sending TCP data
7	Error during TLS connect
8	Error while generating HTTP data (HTTP-Generator)
9	Error while parsing HTTP data (HTTP-Parser)
10	Timeout for whole HTTP-Request +HTTP-Response
11	Error while Protocol switch handshake
12	Error while File access Open
13	Error while File access Close
14	Error while File access Read
15	Error while File access Write

Table 13. AT-S.Certificate Error:=Error ID=

ERROR ID	Description
0	Reserved

ERROR ID	Description
1	Reserved
2	Subject certificate is null or length is zero
3	Parsing the certificate failed
4	Common name does not match (wildcard certificate)
5	Common name does not match
6	Desired key usage is not permitted
7	Parsing the AuthorityKeyId extension failed
8	Initializing decryption of signature failed
9	Decryption of signature failed
10	Invalid signature
11	Parsing the signature failed
12	Parsing the authority certificate failed
13	Missing subject key id extension
14	Parsing the SubjectKeyId extension failed
15	SubjectKeyId does not match AuthorityKeyId
16	Desired key usage is not permitted
17	Basic constraints are not good
18	Parsing the AuthorityKeyId extension failed
19	The certificate is not supported
20	The certificate has been revoked
21	The certificate has expired
22	An unspecified error has occurred
23	The CA could not be found
24	Reserved
25	Reserved

WIND messages

The following table lists the asynchronous messages. The message format is: +WIND:<WIND ID>:<WIND Message>[:<Variables>]

Table 14. WIND messages

WIND ID	WIND message	Variables	Description	Application notes
0	"Console active"			After a reset, wait for this wind message before sending commands
1	"Poweron"	%s-%s-%s	DATE,BUILD,MODEL	
2	"Reset"			
3	"Watchdog Running"	%u	Configured watchdog timeout	
4	"Low Memory"			

WIND ID	WIND message	Variables	Description	Application notes
5	"WiFi Hardware Failure"	%u	DEAD Reason. Range of values: 1. Shown when a WiFi exception "WIND:31" happens 2. Shown when a WPA Init "WIND:50" happens 3. Shown when startup "WIND:32" cannot be reached 4. Shown when driver is not able to write to cw1100 5. Shown when cw1100 does not send an ack within given timeout	
6	Reserved			
7	"Configuration Failure"	%u	Failure reason. Range of values: 1. Reserved 2. Reserved 3. Reserved 4. Shown when RTC cannot be initialized 5. Reserved 6. Shown when System Tick cannot be initialized 7. Shown when Flash cannot be written 8. Shown when uPython detects a fatal error 9. Shown when UART/SPI queues cannot be created 10. (Does not Halt) Shown when HW pull-up resistor has no match with enabled interface 11. (Does not Halt) Shown when Ext SPI Flash cannot be formatted 12. (Does not Halt) Shown when Ext SPI Flash cannot be mounted 13. Shown when APP disk cannot be mounted 14. Shown when RAM disk cannot be created	
8	"Hard Fault"	%s:(%08x)*8	Task, name, STM32 registers content	
9	"StackOverflow"	%s	Task name	
10	"Malloc Failed"	%s:%d:%d	Task name, Required Size, Available Size	
11	"Radio Startup Failure"	%u:%08x	Failure Reason, Found register content. Range of Values 1. Shown when cw1100 Prefetch bit cannot be set 2. Shown when cw1100 Firmware cannot be uploaded 3. Shown when cw1100 is not evaluated as sane 4. Shown when cw1100 DPLL register cannot be set 5. Shown when cw1100 cannot be woken up 6. Shown when cw1100 ID low register is evaluated as bad 7. Shown when cw1100 ID medium register is evaluated as bad 8. Shown when cw1100 ID high register is evaluated as bad 9. Shown when cw1100 cannot be set in Direct Mode 10. Shown when cw1100 cannot be set in ETF Mode	
12	"WiFi PS Mode Failure"	%u:%d	Failure Reason, Found status. Range of Values 1. Shown when cw1100 is not allowing PM set 2. Shown when AP does not provide an answer within given timeout 3. Shown when cw1100 raises this event	
13	"Copyright (c) 2012-2017 STMicroelectronics, Inc. All rights Reserved"	%s	nv_model configuration variable	

WIND ID	WIND message	Variables	Description	Application notes
14	"WiFi BSS Regained"	%d	Threshold	
15	"WiFi Signal Low"	%d	RSSI	
16	"WiFi Signal Ok"	%d	RSSI	
17	Boot Messages	Boot %u.%u	Welcome message from FW update	UART baudrate is hardcoded to 115200. Message string (%s) cannot be removed through console_winds configuration variable.
		Aborting F/W update:%u	Shown when FW cannot be updated (GPIO0 / CRC). Cleanup.	
		Performing F/W update	Shown when FW was validated (before write)	
		Completed F/W update	Shown when FW was updated. Cleanup	
		Cleanup	Shown when mass storage is going to be erased	
18	"Keytype not implemented"	%u	Required Key Type	
19	"WiFi Join"	%m	AP MAC Address	
20	"WiFi Join Failed"	%04x	Failure Reason. Range of Values 0001 – Shown when cw1100 cannot be configured 0002 – Shown when cw1100 does not send an ack within a given timeout 0003 – shown when cw1100 cannot be configured after join operation Shown when cw1100 reply status is evaluated as bad	
21	"WiFi Scanning"			
22	"Scan Blew Up"			
23	"Scan Failed"	%04x	Cw1100 reply status	
24	"WiFi Up"	%u:%i	IPFlag (0 → IPv4; 1 → temporary IPv4 coming from AutoIP), IPv4/6 address	It may be printed up twice with both the IP addresses. The WIND concludes the association process with the remote AP
25	"WiFi Association successful"	%s	SSID	
26	"Started AP"	%s	SSID	
27	"AP Start Failed"	%04x	Cw1100 reply status	
28	"Station Associated"	%m:%u	Peer MAC Address, Re-association flag	
29	"DHCP Reply"	%i:%m	Peer IPv4 address, Peer MAC Address	
30	"WiFi BSS Lost"			
31	"WiFi Exception"	%u:%s:%08x:%08x	Reason, File Name, cw1100 registers content	
32	"WiFi Hardware Started"			Wait for this WIND before switching on the radio
33	"WiFi Network Lost"			
34	"WiFi Unhandled Event"	%02x	Detected Event	
35	"WiFi Scan Complete"	%02x	Aborting Reason	
36	"WiFi Unhandled Indication"	%02x	Detected Indication	
37	Reserved			

WIND ID	WIND message	Variables	Description	Application notes
38	"WiFi Powered Down"			
39	"HW in MiniAP Mode"			
40	"WiFi Deauthentication"	%u	Refer to standard	
41	"WiFi Disassociation"	%u	Refer to standard	
42	"WiFi Unhandled Management"	%02x	Received Frame	
43	"WiFi Unhandled Data"	%02x	Received Frame	
44	"WiFi Unknown Frame"	%04x	Received Frame	
45	"Dot11 AuthIllegal"	%u:%u	Authentication Algorithm, authentication sequence	
46	"WPA Crunching PSK"	%s:%u	PSK,length	
47	Reserved			
48	Reserved			
49	"WPA Terminated"	%d	Exit Status	
50	"WPA Start Failed"	%u	Failure Reason. Range Values. 1. Shown when WPA Supplicant was not able to start 2. Shown when WPA Supplicant was not able to create peer table	
51	"WPA Handshake Complete"			
52	"GPIO Interrupt"	%u:%u	GPIO number, level	
53	"Wakeup"			
54	Reserved			
55	"Pending Data"	%u:%u:%u:%u	Server ID, Client ID, Received bytes, cumulative bytes	
56	"Input to remote"	%u	Input ID	Only printed when buffer for input request is empty. Buffer is filled and cleared by AT +S.INPUTSSI command
57	"Output from remote"	%u:%s	Received message length, message	Maximum allowed length is 128. Every message longer than 128 will be truncated. Use multipart/form-data webservice capability to send more than 128 bytes. Refer to AN4965 "WebServer on SPWF04S module
58	"Socket Closed"	%u:%u	Client ID Closure Reason. Values range 0. Shown when remote TCP sent a FIN 1. Shown when Remote TCP sent a RST, or did not reply to FINACK 2. Shown when too many retransmissions have occurred 3. Shown when network layer has broken 4. Shown when a timeout occurred 5. Shown when ICMP Destination Unreachable was received	AT+S.SOCKC/AT +S.SOCKDC needs to be called to flush the buffer and clear the socket state

WIND ID	WIND message	Variables	Description	Application notes
59	Reserved			
60	Reserved			
61	"Incoming Socket Client"	%i:%u:%u:%u	Client IP, client Port, server ID, client ID	
62	"Socket Client Gone"	%i:%u:%u:%u: %u	Client IP, client Port, server ID, client ID, closure reason	
63	"Socket Dropping Data"	%u:%u:%u	Server ID, client ID, dropped bytes	
64	"Remote Configuration"	%s:%s	Configuration item, configuration value	Item called "Key" is only shown when different from user_desc password
65	"Factory Reset"	%u	Restore Reason. Values Range 0.GPIO0 high at start-up, or reset line not stable 1.CRC check failure on saved configuration	
66	"Low Power Mode"	%u	Powersave Value. Values Range 1. Standard Powersave 2. Fast Powersave	
67	"Going into Standby"	%u	Configured Standby Time	
68	"Resuming from Standby"			
69	"Going into DeepSleep"			
70	"Resuming from DeepSleep"			
71	Reserved			
72	"Station Disassociated"	%m:%u	Peer MAC Address, reason code	
73	"System Configuration Updated"			
74	"Rejected found Network"			
75	"Rejected Association"	%04x	Rejection Reason. Values Range Shown when cw1100 cannot be configured 0xffff – shown when WPA Supplicant was not able allocate memory	
76	"WiFi Authentication Timed Out"			
77	"WiFi Association Timed Out"			
78	"MIC Failure"			
79	Reserved			
80	"UDP Broadcast Received"	%u:%i:%u:%u: %s	Server ID, Client IP, client port, datagram size, datagram content	
81	"WPS generating DH keyset"			
82	"WPS enrollment attempt timed out"			
83	"Sockd Dropping Client"	%u	Dropping reason 1. Not enough RAM to allow access to socket client 2. Too many clients are connected (only when UDP)	
84	"NTP Server Delivery"	%u.%u.%u:%u: %u.%u.%u	Year, month,day,day of week, hour, min,sec	

WIND ID	WIND message	Variables	Description	Application notes
85	"DHCP failed to get a lease"	%u	Failure reason. Range Values. 0. Shown when DHCP server does not respond 1. Shown when DHCP server answer has a wrong message format 2. Shown when given timeout value is not acceptable 3. Shown when received a NACK 4. Shown when DHCP server does not provide an IP address 5. Shown when DHCP server provide a lease time smaller than 50s 6. Shown when DHCP Lease Time expired	
86	"MQTT Published"	%u:%s:%u:%u: %u:%u:%u:%s	Client ID, topic,QoS,retain,dupl,msg siz,tot siz,msg	
87	"MQTT Closed"	%u:%u	Closure reason (0: connection level; 1: MQTT protocol level), Client ID	
88	"WebSocket Data"	%u:%u:%u:%u: %u	Client ID, lastframe flag, lastfrag flag rcv bytes, cumulated bytes	
89	"WebSocket Closed"	%u	Client ID	AT+S.WSOCKC needs to be called to flush the buffer and clear the websocket state
90	"File Received"	%i:%s	Client IP (only provided if file comes from TFTP client), Filename	

Revision history

Table 15. Document revision history

Date	Version	Changes
03-Mar-2017	1	Initial release.
14-Nov-2017	2	Added un-maskable results for AT-Commands. Added FW1.1.0 new features. Added part number in Table 6. Technology partners.
27-Nov-2018	3	Update Section 1 SPWF04Sx software architecture description . Added Section 6.12 AT+S.FSWRITE and Section 6.28 AT+S.FSM . Minor text changes.

Contents

1	SPWF04Sx software architecture description	2
2	Interface and message types	4
3	AT commands over the UART	7
4	SPI protocol	8
5	MicroPython Scripting	10
6	Command reference guide	11
6.1	AT	11
6.2	AT+S.HELP	11
6.3	AT+S.STS	11
6.4	AT+S.PEERS	12
6.5	AT+S.RESET	13
6.6	AT+S.PMS	13
6.7	AT+S.PYTHON	14
6.8	AT+S.GCFG	14
6.9	AT+S.SCFG	14
6.10	AT+S.WCFG	15
6.11	AT+S.FCFG	15
6.12	AT+S.FSWRITE	15
6.13	AT+S.FSUPDATE	16
6.14	AT+S.FWUPDATE	16
6.15	AT+S.GPIOC	17
6.16	AT+S.GPIOR	17
6.17	AT+S.GPIOW	18
6.18	AT+S.DAC	18
6.19	AT+S.ADC	18
6.20	AT+S.PWM	19
6.21	AT+S.TIME	19
6.22	AT+S.RANDOM	20
6.23	AT+S.FSC	20

6.24	AT+S.FSD	20
6.25	AT+S.FSR	21
6.26	AT+S.FSL	21
6.27	AT+S.FSP	22
6.28	AT+S.FSM	22
6.29	AT+S.FSU	22
6.30	AT+S.HASH	23
6.31	AT+S.WPAECERT	23
6.32	AT+S.TLSCERT	24
6.33	AT+S.WPS	24
6.34	AT+S.WIFI	25
6.35	AT+S.SCAN	25
6.36	AT+S.SSIDTXT	26
6.37	AT+S.PING	26
6.38	AT+S.SOCKON	26
6.39	AT+S.SOCKQ	27
6.40	AT+S.SOCKC	28
6.41	AT+S.SOCKW	28
6.42	AT+S.SOCKR	28
6.43	AT+S.SOCKL	29
6.44	AT+S.SOCKDON	29
6.45	AT+S.SOCKDQ	30
6.46	AT+S.SOCKDC	30
6.47	AT+S.SOCKDW	31
6.48	AT+S.SOCKDR	31
6.49	AT+S.SOCKDL	31
6.50	AT+S.TFTPGET	32
6.51	AT+S.TFTPPUT	32
6.52	AT+S.SMTP	33
6.53	AT+S.HTTPGET	33

6.54	AT+S.HTTPPOST	34
6.55	AT+S.INPUTSSI	35
6.56	AT+S.MQTTCONN	35
6.57	AT+S.MQTTPUB	36
6.58	AT+S.MQTTDISC	36
6.59	AT+S.MQTTSUB	37
6.60	AT+S.MQTTUNSUB	37
6.61	AT+S.WSOCKON	37
6.62	AT+S.WSOCKQ	38
6.63	AT+S.WSOCKC	38
6.64	AT+S.WSOCKW	39
6.65	AT+S.WSOCKR	39
6.66	AT+S.WSOCKL	39
7	Technology partners	41
8	Variables and values	42
9	Synchronous errors and WIND messages	50
	Variables and values	0
	Synchronous errors and WIND messages	0
	Revision history	60

List of tables

Table 1.	SPWF04Sx commands	4
Table 2.	KindOfEvent Byte SubField	8
Table 3.	Indication number field	8
Table 4.	Power states and configuration	13
Table 5.	Association between file extension and HTTP content-type	34
Table 6.	Technology partners	41
Table 7.	Configuration variables	42
Table 8.	Status variables	47
Table 9.	Peer variables	49
Table 10.	AT-S.ERROR:=ERROR ID= =ERROR String=	50
Table 11.	AT-S.WebSocket Client Error:=Error ID=	53
Table 12.	AT-S.Http Client Error:=Error ID=	53
Table 13.	AT-S.Certificate Error:=Error ID=	53
Table 14.	WIND messages	54
Table 7.	Configuration variables	0
Table 8.	Status variables	0
Table 9.	Peer variables	0
Table 10.	AT-S.ERROR:=ERROR ID= =ERROR String=	0
Table 11.	AT-S.WebSocket Client Error:=Error ID=	0
Table 12.	AT-S.Http Client Error:=Error ID=	0
Table 13.	AT-S.Certificate Error:=Error ID=	0
Table 14.	WIND messages	0
Table 15.	Document revision history	60

List of figures

Figure 1.	SPWF04Sx user integration modes	1
Figure 2.	SPWF04Sx software architecture	2
Figure 3.	SPWF04Sx protocol stack diagram	3
Figure 4.	SPI packet formats	8
Figure 5.	MicroPython modes	10
Figure 6.	AP capabilities list	25

IMPORTANT NOTICE – PLEASE READ CAREFULLY

STMicroelectronics NV and its subsidiaries (“ST”) reserve the right to make changes, corrections, enhancements, modifications, and improvements to ST products and/or to this document at any time without notice. Purchasers should obtain the latest relevant information on ST products before placing orders. ST products are sold pursuant to ST’s terms and conditions of sale in place at the time of order acknowledgement.

Purchasers are solely responsible for the choice, selection, and use of ST products and ST assumes no liability for application assistance or the design of Purchasers’ products.

No license, express or implied, to any intellectual property right is granted by ST herein.

Resale of ST products with provisions different from the information set forth herein shall void any warranty granted by ST for such product.

ST and the ST logo are trademarks of ST. All other product or service names are the property of their respective owners.

Information in this document supersedes and replaces information previously supplied in any prior versions of this document.

© 2018 STMicroelectronics – All rights reserved