

## 54F/74F160A • 74F162A Synchronous Presettable BCD Decade Counter

### General Description

The 'F160A and 'F162A are high-speed synchronous decade counters operating in the BCD (8421) sequence. They are synchronously presettable for applications in programmable dividers. There are two types of Count Enable inputs plus a Terminal Count output for versatility in forming synchronous multistage counters. The 'F160A has an asynchronous Master Reset input that overrides all other inputs and forces the outputs LOW. The 'F162A has a Synchronous Reset input that overrides counting and parallel load-

ing and allows all outputs to be simultaneously reset on the rising edge of the clock. The 'F160A and 'F162A are high speed versions of the 'F160 and 'F162.

### Features

- Synchronous counting and loading
- High-speed synchronous expansion
- Typical count rate of 120 MHz
- Guaranteed 4000V minimum ESD protection

**Ordering Code:** See Section 11

| Commercial         | Military           | Package Number | Package Description                               |
|--------------------|--------------------|----------------|---|
| 74F160APC          |                    | N16E           | 16-Lead (0.300" Wide) Molded Dual-in-Line         |
|                    | 54F160ADM (Note 2) | J16A           | 16-Lead Ceramic Dual-in-Line                      |
| 74F160ASC (Note 1) |                    | M16A           | 16-Lead (0.150" Wide) Molded Small Outline, JEDEC |
| 74F160ASJ (Note 1) |                    | M16D           | 16-Lead (0.300" Wide) Molded Small Outline, EIAJ  |
|                    | 54F160AFM (Note 2) | W16A           | 16-Lead Cerpack                                   |
|                    | 54F160ALM (Note 2) | E20A           | 20-Lead Ceramic Leadless Chip Carrier, Type C     |
| 74F162APC          |                    | N16E           | 16-Lead (0.300" Wide) Molded Dual-In-Line         |
| 74F162ASC (Note 1) |                    | M16A           | 16-Lead (0.150" Wide) Molded Small Outline, JEDEC |
| 74F162ASJ (Note 1) |                    | M16D           | 16-Lead (0.300" Wide) Molded Small Outline, EIAJ  |

**Note 1:** Devices also available in 13" reel. Use suffix = SCX and SJX.

**Note 2:** Military grade device with environmental and burn-in processing. Use suffix = DMOB, FMOB and LMOB.

### Connection Diagrams

**Pin Assignment for  
DIP, SOIC and Flatpak**

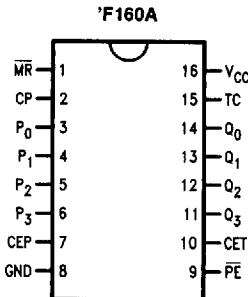

TL/F/9485-1

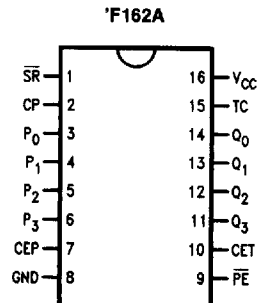

TL/F/9485-9

# Logic Symbols

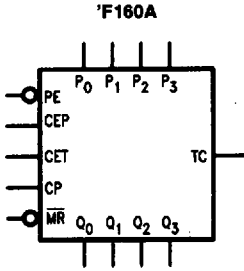

TL/F/9485-3

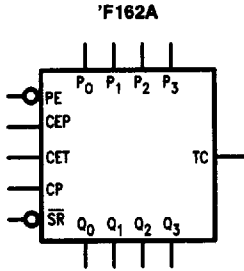

TL/F/9485-8

## IEEE/IEC

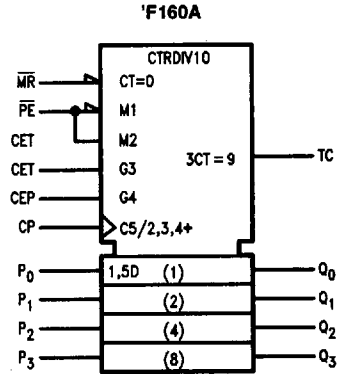

TL/F/9485-6

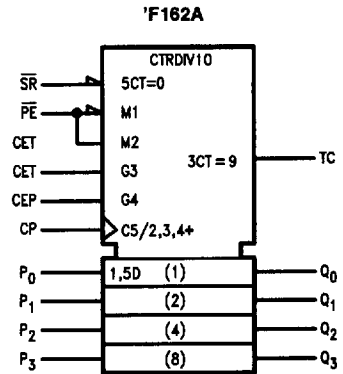

TL/F/9485-7

### Unit Loading/Fan Out: See Section 2 for U.L. definitions

| Pin Names                      | Description                                  | 54F/74F          |   |
|--------------------------------|--|------------------|---|
|                                |  | U.L.<br>HIGH/LOW | Input $I_{IH}/I_{IL}$<br>Output $I_{OH}/I_{OL}$ |
| CEP                            | Count Enable Parallel Input                  | 1.0/1.0          | 20 $\mu$ A / -0.6 mA                            |
| CET                            | Count Enable Trickle Input                   | 1.0/2.0          | 20 $\mu$ A / -1.2 mA                            |
| CP                             | Clock Pulse Input (Active Rising Edge)       | 1.0/1.0          | 20 $\mu$ A / -0.8 mA                            |
| $\overline{MR}$ ('F160A)       | Asynchronous Master Reset Input (Active LOW) | 1.0/1.0          | 20 $\mu$ A / -0.6 mA                            |
| $\overline{SR}$ ('F162A)       | Synchronous Reset Input (Active LOW)         | 1.0/2.0          | 20 $\mu$ A / -1.2 mA                            |
| P <sub>0</sub> -P <sub>3</sub> | Parallel Data Inputs                         | 1.0/1.0          | 20 $\mu$ A / -0.8 mA                            |
| PE                             | Parallel Enable Input (Active LOW)           | 1.0/2.0          | 20 $\mu$ A / -1.2 mA                            |
| Q <sub>0</sub> -Q <sub>3</sub> | Flip-Flop Outputs                            | 50/33.3          | -1 mA / 20 mA                                   |
| TC                             | Terminal Count Output                        | 50/33.3          | -1 mA / 20 mA                                   |

## Functional Description

The 'F160A and 'F162A count modulo-10 in the BCD (8421) sequence. From state 9 (HLLH) they increment to state 0 (LLLL). The clock inputs of all flip-flops are driven in parallel through a clock buffer. Thus all changes of the Q outputs (except due to Master Reset of the ('F160A) occur as a result of, and synchronous with, the LOW-to-HIGH transition of the CP input signal. The circuits have four fundamental modes of operation, in order of precedence: asynchronous reset ('F160A), synchronous reset ('F162A), parallel load, count-up and hold. Five control inputs—Master Reset ( $\overline{MR}$ , 'F160A), Synchronous Reset ( $\overline{SR}$ , 'F162A), Parallel Enable ( $\overline{PE}$ ), Count Enable Parallel (CEP) and Count Enable Trickle (CET)—determine the mode of operation, as shown in the Mode Select Table. A LOW signal on  $\overline{MR}$  overrides all other inputs and asynchronously forces all outputs LOW. A LOW signal on  $\overline{SR}$  overrides counting and parallel loading and allows all outputs to go LOW on the next rising edge of CP. A LOW signal on  $\overline{PE}$  overrides counting and allows information on the Parallel Data ( $P_n$ ) inputs to be loaded into the flip-flops on the next rising edge of CP. With  $\overline{PE}$  and  $\overline{MR}$  ('F160A) or  $\overline{SR}$  ('F162A) HIGH, CEP and CET permit counting when both are HIGH. Conversely, a LOW signal on either CEP or CET inhibits counting.

The 'F160A and 'F162A use D-type edge-triggered flip-flops and changing the  $\overline{SR}$ ,  $\overline{PE}$ , CEP and CET inputs when the CP is in either state does not cause errors, provided that the recommended setup and hold times, with respect to the rising edge of CP, are observed.

The Terminal Count (TC) output is HIGH when CET is HIGH and counter is in state 9. To implement synchronous multi-stage counters, the TC outputs can be used with the CEP and CET inputs in two different ways. Please refer to the 'F568 data sheet. The TC output is subject to decoding spikes due to internal race conditions and is therefore not recommended for use as a clock or asynchronous reset for flip-flops, counters or registers. In the 'F160A and 'F162A decade counters, the TC output is fully decoded and can only be HIGH in state 9. If a decade counter is preset to an illegal state, or assumes an illegal state when power is applied, it will return to the normal sequence within two counts, as shown in the State Diagram.

Logic Equations:

$$\text{Count Enable} = \text{CEP} \times \text{CET} \times \overline{\text{PE}}$$

$$\text{TC} = Q_0 \times \overline{Q_1} \times \overline{Q_2} \times Q_3 \times \text{CET}$$

Mode Select Table

| * $\overline{SR}$ | $\overline{PE}$ | CET | CEP | Action on the Rising Clock Edge (⤴) |
|-------------------|-----------------|-----|-----|-------------------------------------|
| L                 | X               | X   | X   | Reset (Clear)                       |
| H                 | L               | X   | X   | Load ( $P_n \rightarrow Q_n$ )      |
| H                 | H               | H   | H   | Count (Increment)                   |
| H                 | H               | L   | X   | No Change (Hold)                    |
| H                 | H               | X   | L   | No Change (Hold)                    |

\*For 'F162A only  
H = HIGH Voltage Level  
L = LOW Voltage Level  
X = Immaterial

State Diagram

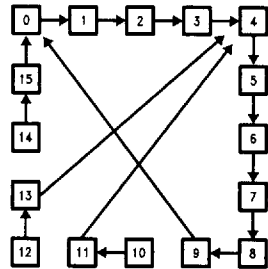

TL/F/9485-4

# Logic Diagram

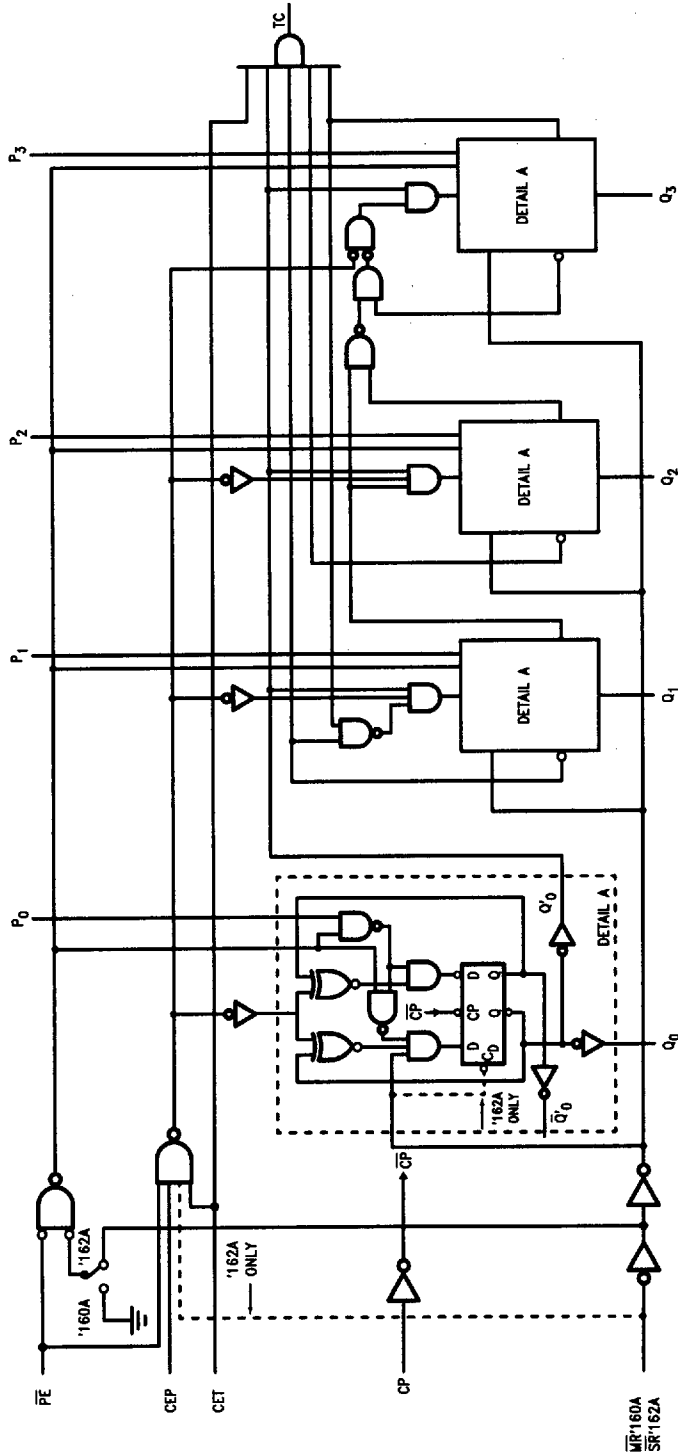

TL/F/9485-5

Please note that this diagram is provided only for the understanding of logic operations and should not be used to estimate propagation delays.

**Absolute Maximum Ratings** (Note 1)

If Military/Aerospace specified devices are required, please contact the National Semiconductor Sales Office/Distributors for availability and specifications.

|                                 |                 |
|---------------------------------|-----------------|
| Storage Temperature             | -65°C to +150°C |
| Ambient Temperature under Bias  | -55°C to +125°C |
| Junction Temperature under Bias | -55°C to +175°C |
| Plastic                         | -55°C to +150°C |

$V_{CC}$  Pin Potential to Ground Pin -0.5V to +7.0V

Input Voltage (Note 2) -0.5V to +7.0V

Input Current (Note 2) -30 mA to +5.0 mA

Voltage Applied to Output in HIGH State (with  $V_{CC} = 0V$ )

Standard Output -0.5V to  $V_{CC}$

TRI-STATE® Output -0.5V to +5.5V

Current Applied to Output in LOW State (Max) twice the rated  $I_{OL}$  (mA)

ESD Last Passing Voltage (Min) 4000V

**Note 1:** Absolute maximum ratings are values beyond which the device may be damaged or have its useful life impaired. Functional operation under these conditions is not implied.

**Note 2:** Either voltage limit or current limit is sufficient to protect inputs.

**Recommended Operating Conditions**

|                              |                 |
|------------------------------|-----------------|
| Free Air Ambient Temperature |                 |
| Military                     | -55°C to +125°C |
| Commercial                   | 0°C to +70°C    |
| Supply Voltage               |                 |
| Military                     | +4.5V to +5.5V  |
| Commercial                   | +4.5V to +5.5V  |

**DC Electrical Characteristics**

| Symbol    | Parameter                         | 54F/74F          |      |      | Units         | $V_{CC}$ | Conditions   |
|-----------|-----------------------------------|------------------|------|------|---------------|----------|--|
|           |                                   | Min              | Typ  | Max  |               |          |  |
| $V_{IH}$  | Input HIGH Voltage                | 2.0              |      |      | V             |          | Recognized as a HIGH Signal                                      |
| $V_{IL}$  | Input LOW Voltage                 | 0.8              |      |      | V             |          | Recognized as a LOW Signal                                       |
| $V_{CD}$  | Input Clamp Diode Voltage         | -1.2             |      |      | V             | Min      | $I_{IN} = -18 \text{ mA}$  |
| $V_{OH}$  | Output HIGH Voltage               | 54F 10% $V_{CC}$ | 2.5  |      | V             | Min      | $I_{OH} = -1 \text{ mA}$   |
|           |                                   | 74F 10% $V_{CC}$ | 2.5  |      |               |          | $I_{OH} = -1 \text{ mA}$   |
|           |                                   | 74F 5% $V_{CC}$  | 2.7  |      |               |          | $I_{OH} = -1 \text{ mA}$   |
| $V_{OL}$  | Output LOW Voltage                | 54F 10% $V_{CC}$ |      | 0.5  | V             | Min      | $I_{OL} = 20 \text{ mA}$   |
|           |                                   | 74F 10% $V_{CC}$ |      | 0.5  |               |          | $I_{OL} = 20 \text{ mA}$   |
| $I_{IH}$  | Input HIGH Current                | 54F              |      | 20.0 | $\mu\text{A}$ | Max      | $V_{IN} = 2.7V$  |
|           |                                   | 74F              |      | 5.0  |               |          | $V_{IN} = 7.0V$  |
| $I_{BVI}$ | Input HIGH Current Breakdown Test | 54F              |      | 100  | $\mu\text{A}$ | Max      | $V_{IN} = 7.0V$  |
|           |                                   | 74F              |      | 7.0  |               |          | $V_{OUT} = V_{CC}$   |
| $I_{CEX}$ | Output HIGH Leakage Current       | 54F              |      | 250  | $\mu\text{A}$ | Max      | $V_{OUT} = V_{CC}$   |
|           |                                   | 74F              |      | 50   |               |          |  |
| $V_{ID}$  | Input Leakage Test                | 74F              | 4.75 |      | V             | 0.0      | $I_D = 1.9 \mu\text{A}$<br>All Other Pins Grounded               |
| $I_{OD}$  | Output Leakage Circuit Current    | 74F              |      | 3.75 | $\mu\text{A}$ | 0.0      | $V_{IOD} = 150 \text{ mV}$<br>All Other Pins Grounded            |
| $I_{IL}$  | Input LOW Current                 |                  |      | -0.6 | mA            | Max      | $V_{IN} = 0.5V$ (CP, CEP, P <sub>n</sub> , M $\bar{R}$ ('F160A)) |
|           |                                   |                  |      | -1.2 |               |          | $V_{IN} = 0.5V$ (CET, S $\bar{R}$ ('F162A), PE)                  |
| $I_{OS}$  | Output Short-Circuit Current      |                  | -60  | -150 | mA            | Max      | $V_{OUT} = 0V$   |
| $I_{CC}$  | Power Supply Current              |                  | 37   | 55   |               |          | $V_O = \text{HIGH}$  |

**AC Electrical Characteristics:** See Section 2 for Waveforms and Load Configurations

| Symbol           | Parameter  | 74F   |      |      | 54F  |      | 74F  |      | Units | Fig. No. |
|------------------|--|---|------|------|--|------|--|------|-------|----------|
|                  |  | T <sub>A</sub> = +25°C<br>V <sub>CC</sub> = +5.0V<br>C <sub>L</sub> = 50 pF |      |      | T <sub>A</sub> , V <sub>CC</sub> = Mil<br>C <sub>L</sub> = 50 pF |      | T <sub>A</sub> , V <sub>CC</sub> = Com<br>C <sub>L</sub> = 50 pF |      |       |          |
|                  |  | Min   | Typ  | Max  | Min  | Max  | Min  | Max  |       |          |
| f <sub>max</sub> | Maximum Count Frequency  | 90  | 120  |      | 75   |      | 80   |      | MHz   | 2-1      |
| t <sub>PLH</sub> | Propagation Delay, Count<br>CP to Q <sub>n</sub> ( $\overline{PE}$ Input HIGH) | 3.5   | 5.5  | 7.5  | 3.5  | 9.0  | 3.5  | 8.5  | ns    | 2-3      |
| t <sub>PHL</sub> |  | 3.5   | 7.5  | 10.0 | 3.5  | 11.5 | 3.5  | 11.0 |       |          |
| t <sub>PLH</sub> | Propagation Delay, Load<br>CP to Q <sub>n</sub> ( $\overline{PE}$ Input LOW)   | 4.0   | 6.0  | 8.5  | 4.0  | 10.0 | 4.0  | 9.5  | ns    | 2-3      |
| t <sub>PHL</sub> |  | 4.0   | 6.0  | 8.5  | 4.0  | 10.0 | 4.0  | 9.5  |       |          |
| t <sub>PLH</sub> | Propagation Delay<br>CP to TC  | 5.0   | 10.0 | 14.0 | 5.0  | 16.5 | 5.0  | 15.0 | ns    | 2-3      |
| t <sub>PHL</sub> |  | 5.0   | 10.0 | 14.0 | 5.0  | 15.5 | 5.0  | 15.0 |       |          |
| t <sub>PLH</sub> | Propagation Delay<br>CET to TC   | 2.5   | 4.5  | 7.5  | 2.5  | 9.0  | 2.5  | 8.5  | ns    | 2-3      |
| t <sub>PHL</sub> |  | 2.5   | 4.5  | 7.5  | 2.5  | 9.0  | 2.5  | 8.5  |       |          |
| t <sub>PHL</sub> | Propagation Delay<br>$\overline{MR}$ to Q <sub>n</sub> ('F160A)                | 5.5   | 9.0  | 12.0 | 5.5  | 14.0 | 5.5  | 13.0 | ns    | 2-3      |
| t <sub>PHL</sub> | Propagation Delay<br>$\overline{MR}$ to TC ('F160A)                            | 4.5   | 8.0  | 10.5 | 4.5  | 12.5 | 4.5  | 11.5 | ns    | 2-3      |

**AC Operating Requirements:** See Section 2 for Waveforms

| Symbol                             | Parameter   | 74F  |     | 54F                        |     | 74F                        |     | Units | Fig. No. |
|------------------------------------|---|--|-----|----------------------------|-----|----------------------------|-----|-------|----------|
|                                    |   | $T_A = +25^\circ\text{C}$<br>$V_{CC} = +5.0\text{V}$ |     | $T_A, V_{CC} = \text{MII}$ |     | $T_A, V_{CC} = \text{Com}$ |     |       |          |
|                                    |   | Min  | Max | Min                        | Max | Min                        | Max |       |          |
| $t_s(\text{H})$<br>$t_s(\text{L})$ | Setup Time, HIGH or LOW<br>$P_n$ to CP ('F160A)                                   | 4.0  |     | 5.5                        |     | 4.0                        |     | ns    | 2-6      |
| $t_s(\text{H})$<br>$t_s(\text{L})$ | Setup Time, HIGH or LOW<br>$P_n$ to CP ('F162A)                                   | 5.0  |     |                            |     | 5.0                        |     | ns    | 2-6      |
| $t_h(\text{H})$<br>$t_h(\text{L})$ | Hold Time, HIGH or LOW<br>$P_n$ to CP   | 2.0  |     | 2.5                        |     | 2.0                        |     |       |          |
| $t_s(\text{H})$<br>$t_s(\text{L})$ | Setup Time, HIGH or LOW<br>$\overline{\text{PE}}$ or $\overline{\text{SR}}$ to CP | 11.0   |     | 13.5                       |     | 11.5                       |     | ns    | 2-6      |
| $t_h(\text{H})$<br>$t_h(\text{L})$ | Hold Time, HIGH or LOW<br>$\overline{\text{PE}}$ or $\overline{\text{SR}}$ to CP  | 2.0  |     | 2.0                        |     | 2.0                        |     |       |          |
| $t_s(\text{H})$<br>$t_s(\text{L})$ | Setup Time, HIGH or LOW<br>CEP or CET to CP                                       | 11.0   |     | 13.0                       |     | 11.5                       |     | ns    | 2-6      |
| $t_h(\text{H})$<br>$t_h(\text{L})$ | Hold Time, HIGH or LOW<br>CEP or CET to CP  | 0  |     | 0                          |     | 0                          |     |       |          |
| $t_w(\text{H})$<br>$t_w(\text{L})$ | Clock Pulse Width (Load)<br>HIGH or LOW   | 5.0  |     | 5.0                        |     | 5.0                        |     | ns    | 2-4      |
| $t_w(\text{H})$<br>$t_w(\text{L})$ | Clock Pulse Width (Count)<br>HIGH or LOW  | 4.0  |     | 5.0                        |     | 4.0                        |     | ns    | 2-4      |
| $t_w(\text{L})$                    | $\overline{\text{MR}}$ Pulse Width, LOW<br>(F160A)                                | 5.0  |     | 5.0                        |     | 5.0                        |     |       |          |
| $t_{\text{rec}}$                   | Recovery Time<br>$\overline{\text{MR}}$ to CP ('F160A)                            | 6.0  |     | 6.0                        |     | 6.0                        |     | ns    | 2-6      |