

# EM-FD-7G Series Safety Extension Module (Delayed Output)

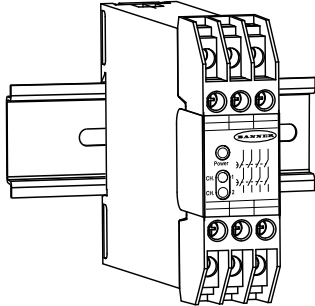

## Datasheet

### One-Channel Control with Four Delayed Safety Output Channels



- Safety Extension Module provides additional safety outputs for a Primary Safety Device (for example, an E-stop safety module or a two-hand control module)
- Features four delayed 6-amp switching channels for connection to control-reliable machine power interrupt circuits
- For use in functional controlled stop category 1 applications per NFPA 79 and EN418
- Contact status outputs are provided for connection to the Primary Safety Device's monitoring input
- 24 V ac/dc operation
- Housed in a narrow, 22.5 mm (0.9 inch) DIN-rail-mountable module
- Design complies with standards UL 991 and EN 60204



#### WARNING: Stand-Alone Point-of-Operation Guarding

The EM-FD-7G Series Safety Extension Module (Delayed Output) is not a stand-alone point-of-operation guarding device, as defined by OSHA regulations. It is necessary to install point-of-operation guarding devices, such as safety light screens and/or hard guards, to protect personnel from hazardous machinery.

Failure to properly install point-of-operation safeguarding on hazardous machinery, as instructed by the appropriate installation manuals, can result in a dangerous condition which may lead to serious injury or death.

## Overview

EM-FD-7G Series Safety Extension Module (Delayed Output) provides additional forced-guided (positive-guided) relay contacts for a Primary Safety Device, such as an E-stop relay or a two-hand control module.

Controlled by a safety output of the Primary Safety Device, the EM-FD-7G Extension Module provides four safety outputs. These outputs may be connected to control-reliable machine power interrupt circuits. Each of the four EM-FD-7G Extension Module safety outputs is a series connection of two forced-guided relay contacts.

The EM-FD-7G Extension Module Series is available in three models with varying OFF delays:

Models	Delay OFF
EM-FD-7G2	0.5 Second
EM-FD-7G3	1 Second
EM-FD-7G4	2 Seconds

The safety outputs of the Safety Extension Module follow the action of the safety output from the Primary Safety Device which controls it, with a switching delay time as noted above. The output delay permits dynamic motor braking typical of variable frequency motor drives and servo motor controllers. The Extension Module's four safety outputs are each rated for up to 250 V ac/dc at up to 6 A.

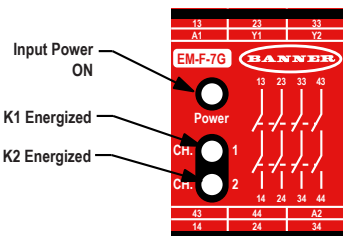

The Safety Extension Module offers an output circuit at terminals Y1 and Y2 which provides K1 and K2 contact status information for connection to the monitoring input of the Primary Safety Device (see [Figure 1](#) on page 5). This monitoring circuit prevents the Primary Safety Device from being reset if contacts of either K1 or K2 of the Extension Module fail in a shorted condition.

The Safety Extension Module has indicators for input power (green), and status of internal relays (K1 and K2, both green). There are no adjustments and no user-serviceable parts. See [Repairs](#) on page 7 for information regarding repair service.



## Important... Read this before proceeding!

---

The user is responsible for **satisfying** all local, state, and **national** laws, rules, codes, and regulations relating to the use of this product and its application. Banner Engineering Corp. has made every effort to provide complete application, installation, operation, and maintenance instructions. Please contact a Banner Applications Engineer with any questions regarding this product.

The user is responsible for making sure that all machine operators, maintenance personnel, electricians, and supervisors are thoroughly familiar with and understand all instructions regarding the installation, maintenance, and use of this product, and with the machinery it controls. The user and any personnel involved with the installation and use of this product must be thoroughly familiar with all applicable standards, some of which are listed within the specifications. Banner Engineering Corp. makes no claim regarding a specific recommendation of any organization, the accuracy or effectiveness of any information provided, or the appropriateness of the provided information for a specific application.

## Standards Applicable to the Use of Primary Safety Devices

### U.S. Standards

#### ANSI B11 Standards for Machine Tools Safety

Contact: Safety Director, AMT – The Association for Manufacturing Technology, 7901 Westpark Drive, McLean, VA 22102, Tel.: 703-893-2900

#### ANSI NFPA 79 Electrical Standard for Industrial Machinery

Contact: National Fire Protection Association, 1 Batterymarch Park, P.O. Box 9101, Quincy, MA 02269-9101, Tel.: 800-344-3555

#### ANSI/RIA R15.06 Safety Requirements for Industrial Robots and Robot Systems

Contact: Robotic Industries Association, 900 Victors Way, P.O. Box 3724, Ann Arbor, MI 48106, Tel.: 734-994-6088

### European Standards

#### ISO/TR 12100-1 (EN 292-1 & -2) Safety of Machinery – Basic Concepts, General Principles for Design

IEC 60204-1 Electrical Equipment of Machines Part 1: General Requirements - Also, request a type "C" standard for your specific machinery

#### ISO 13850 (EN 418) Emergency Stop Devices, Functional Aspects – Principles for Design

Contact: Global Engineering Documents, 15 Inverness Way East, Englewood, CO 80112-5704, Tel.: 800-854- 7179

## Specifications

---

### Supply Voltage and Current

A1-A2: 24 V ac/dc,  $\pm 10\%$ , 10% maximum ripple on dc

### Supply Protection Circuitry

Protected against reverse polarity and transient voltages

### Output Configuration

Four output channels: Each channel is a series connection of two forced-guided (positive-guided) safety relay contacts – AgSnO<sub>2</sub>

#### Contact ratings:

Maximum voltage: 250 V ac/dc  
 Maximum current: 6 A ac/dc (at specified operating temperature)  
 Minimum current: 30 mA at 10 V dc  
 Maximum power: 1500 VA, 150 W  
 Mechanical life: 10,000,000 operations  
 Electrical life: 100,000 at full resistive load  
 Feedback contact rating (Y1-Y2): 250 V ac/dc at 3.0A

NOTE: Transient suppression is recommended when switching inductive loads. Install suppressors across load. Never install suppressors across output contacts.

### Status Indicators

3 green LED indicators: Power ON, K1 energized, K2 energized

### Construction

Polycarbonate housing

### Mounting

Mounts to standard 35 mm DIN-rail track

### Input Requirements

Input from Primary Safety Device must be capable of switching 40 to 100 mA at 13 to 27 V ac/dc

### Output Response Time

Delay OFF (as measured from the time when the supply voltage to A1 is interrupted):

0.5 sec  $\pm 30\%$  for model EM-FD-7G2  
 1 sec  $\pm 30\%$  for model EM-FD-7G3  
 2 sec  $\pm 30\%$  for model EM-FD-7G4

Delay ON: 30 milliseconds for all models

**Environmental Rating**

Rated NEMA 1, IEC IP20  
 Safety Extension Module must be installed inside an enclosure rated NEMA 3 (IEC IP54), or better.

**Vibration Resistance**

10 to 55Hz at 0.35 mm displacement per IEC68-2-6

**Operating Temperature**

0 °C to +50 °C (+32 °F to +122 °F)

**Application Notes**

There are no adjustments and no user-serviceable parts. See [Repairs](#) on page 7 for information regarding repair service.

**Certifications**



**Required Overcurrent Protection**



**WARNING:** Electrical connections must be made by qualified personnel in accordance with local and national electrical codes and regulations.

Overcurrent protection is required to be provided by end product application per the supplied table. Overcurrent protection may be provided with external fusing or via Current Limiting, Class 2 Power Supply. Supply wiring leads < 24 AWG shall not be spliced. For additional product support, go to [www.bannerengineering.com](http://www.bannerengineering.com).

Supply Wiring (AWG)	Required Overcurrent Protection (Amps)
20	5.0
22	3.0
24	2.0
26	1.0
28	0.8
30	0.5

**Dimensions**

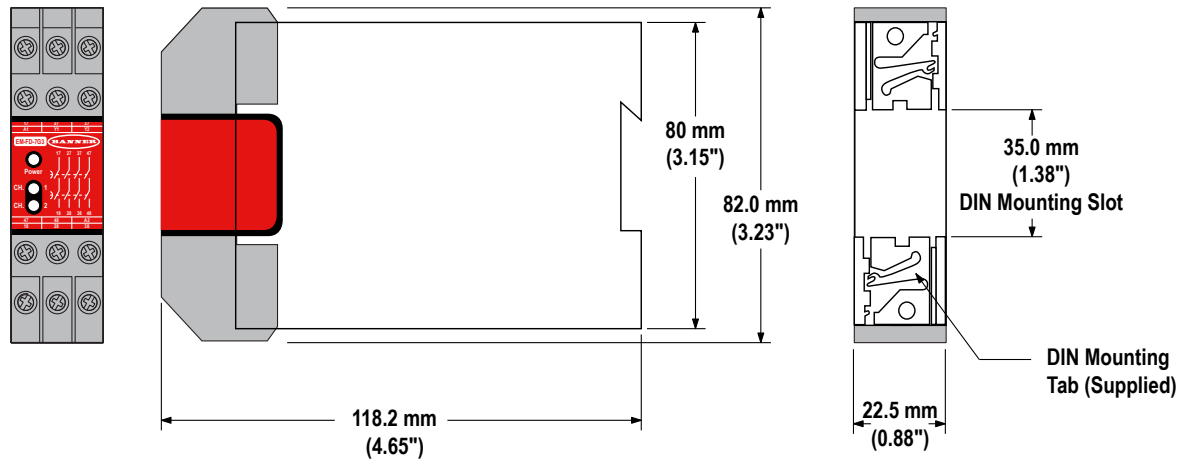

**Installation Instructions**

**Primary Safety Device Requirements**

An EM-FD-7G Extension Module is driven by one safety output channel of a Primary Safety Device. The design of the Primary Safety Device must meet OSHA and ANSI control reliability requirements. The EM-FD-7G Extension Module must be used only with a Primary Safety Device which has a dedicated input for feedback monitor contacts (see wiring diagram).

The output channel of the Primary Safety Device must meet the following requirements:

- Include two (or more) redundant, normally open forced-guided (positive-guided) contacts,
- Be self-monitored to result in a safe (open) condition in the event of a contact failure, and
- Be capable of switching 40 to 100 mA at 13 to 27 V ac/dc.

**WARNING:****Not for Use As a Stand-Alone Safety Relay**

1. DO NOT connect E-stop switches, 2-hand control switches, safety interlock switches, or similar devices directly to this Extension Module.
2. ALWAYS connect terminals Y1 and Y2 of this Extension Module to the monitoring input of the Primary Safety Device that controls it (see wiring diagram).

This Safety Extension Module does not have the circuitry required to perform a self-check. A single fault inside the unit or in external devices like switches or E-stop buttons connected to the unit can go undetected and create an unsafe condition. Failure to properly connect this Safety Extension Module to a control-reliable Primary Safety Device could result in serious injury or death.



**WARNING: Dangerous Voltages.** Always disconnect all power from the Safety Extension Module, the Primary Safety Device, and from the machine being controlled before making any wire connections. Electrical installation and wiring must be made by qualified personnel and must comply with the NEC (National Electrical Code), EN 60204-1 and -2, and all applicable local standards and codes.

## Mechanical Installation

The Safety Module must be installed inside an enclosure.

It is not designed for exposed wiring. It is the user's responsibility to house the Safety Module in an enclosure with NEMA 3 (IEC IP54) rating, or better. The Safety Module mounts directly to standard 35 mm DIN rail.

**Heat Dissipation Considerations:** For reliable operation, ensure that the operating specifications are not exceeded. The enclosure must provide adequate heat dissipation, so that the air closely surrounding the Module does not exceed the maximum operating temperature stated in the Specifications. Methods to reduce heat build-up include venting, forced airflow (for example, exhaust fans), adequate enclosure exterior surface area, and spacing between modules and other sources of heat.

## Electrical Installation

Because the EM-FD-7G Extension Module can be used with many different Primary Safety Devices and can interface to a multitude of machine control configurations, it is not possible to give exact wiring instructions for the output contacts. The following guidelines are general in nature.

The output contacts of the Extension Module have a delay function. They will open within the specified delay after the controlling contacts coming from the Primary Safety Device open.

Models	Delay OFF
EM-FD-7G2	0.5 Second
EM-FD-7G3	1 Second
EM-FD-7G4	2 Seconds



**WARNING: Possible OFF-Delay Failure.** The delay outputs of EM-FD-7G Extension Module may open faster than the OFF-delays specified in the chart, due to a failure within the module. In applications that require a specified OFF-delay (to operate a machine brake, for example), in which such a failure could result in a hazardous situation, the installation, including its wiring, must be designed to prevent such a hazard.

**WARNING: Use of Arc Suppressors**

If arc suppressors are used, they **MUST** be installed as shown across the coils of the Machine Primary Control Elements (MPCs). **NEVER** install suppressors directly across the output contacts of the Safety Module. It is possible for suppressors to fail as a short circuit. If installed directly across the output contacts of the Safety Module, a short-circuited suppressor creates an unsafe **condition** which may result in serious injury or death.

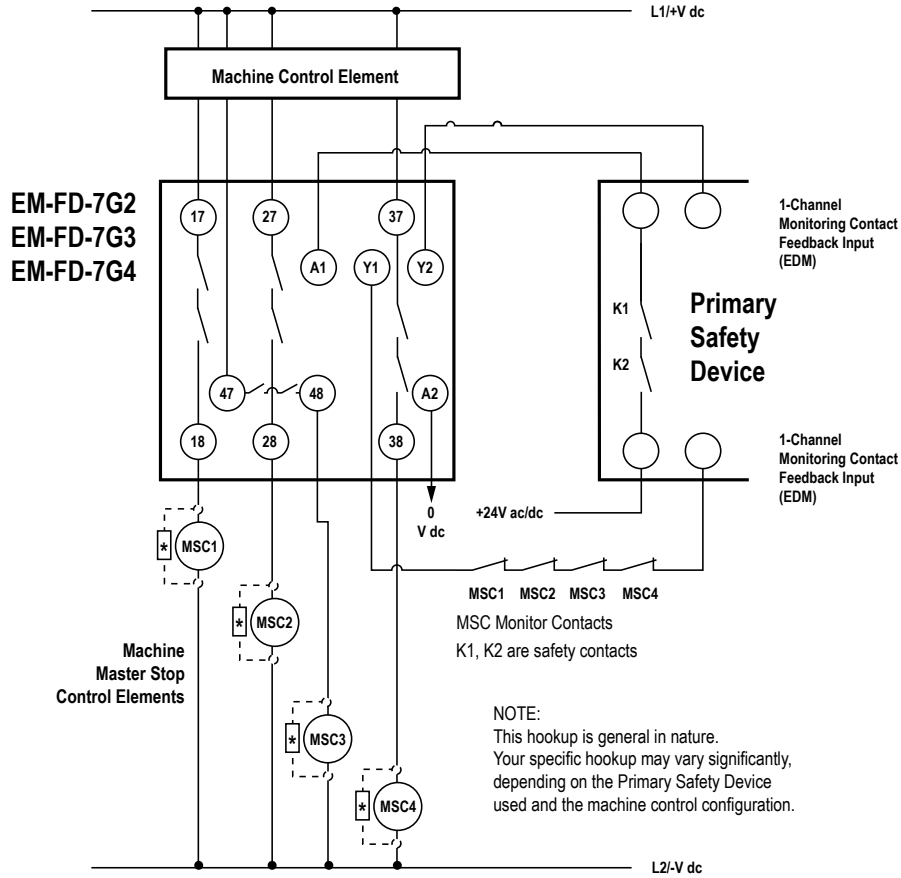

Figure 1. Generalized EM-FD-7G Series Connection Diagram

**One-Channel Control**

One-channel control affords simplicity of wiring. However, one-channel wiring requires eliminating the possibility of an unsafe failure of the control wires (which connect the output of the Primary Safety Device to the input of the Extension Module). One of the ways to reduce the probability of such failure is to locate the Primary Safety Device adjacent to the Safety Extension Module, in the same enclosure.

The output of the Primary Safety Device must consist of two or more series-connected, normally open contacts, coming from forced-guided safety relays. These contacts must be monitored for failure by the Primary Safety Device. In addition, a single contact failure cannot prevent normal stopping action, and a successive cycle cannot be initiated until the failure has been corrected. An example of this type of output is any single output channel of a Banner E-stop safety module.

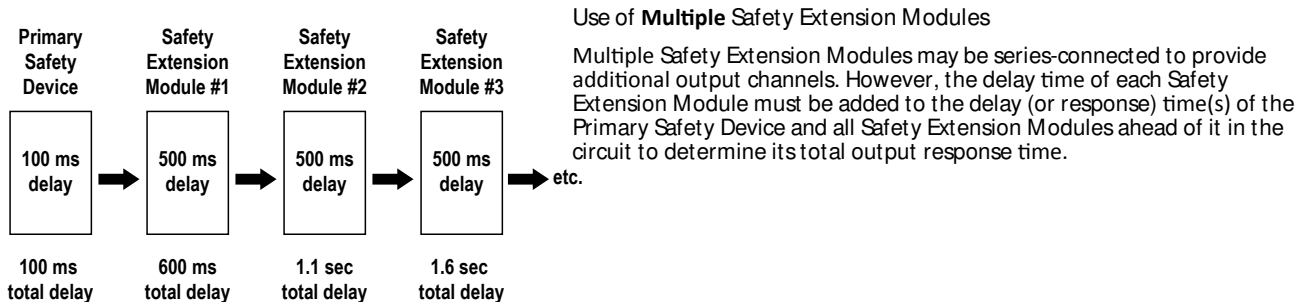

Figure 2. Calculating the total delay response of each Safety Extension Module in a multiple-module circuit

Whenever more than one Safety Extension Module is controlled by one Primary Safety Device, the monitoring contacts of all Safety Extension Modules (terminals Y1 and Y2) must be wired together in series and connected to the Monitoring Contact Feedback Input of the Primary Safety Device.



**WARNING:** Maintain Control Reliability. NEVER wire an intermediate device (e.g., a programmable logic controller/ PLC), other than a safety relay, between any safety output of the Safety Extension Module and the master stop control element it switches. To do so sacrifices the control reliability of the control-to-machine interface, and creates an unsafe condition that could result in serious injury or death. Whenever a safety relay is added as an intermediate switching device, a normally-closed forced-guided monitor contact of that relay must be added to the series feedback loop. (Reference ANSI B11.1 – 1988, Appendix B4)

## Connection to the Machine to be Controlled

Some machines, such as those using dynamic motor braking, require power to be provided during the braking action. EM-FD-7G Series Safety Extension Module (Delayed Output) offers delayed OFF time to accomplish this type of controlled stop. This is a Category 1 Stop, per EN418 and NFPA 79.

The wiring diagram shows a generic connection of the four safety output channels of the Safety Extension Module to Master Stop Control Elements MSC1 through MSC4. A Master Stop Control Element is defined as an electrically powered device, external to the Extension Module, which stops the machinery being controlled by immediately removing the electrical power to the machine and (when necessary) by applying braking to dangerous motion (reference ANSI B11.19, section 5.2: “Stop Control”). To achieve control reliability, two redundant MSCs are required to control each machine hazard.

To satisfy the requirements of control reliability, all MSCs must offer at least one normally closed forced-guided monitor contact. One normally closed monitor contact from each MSC is wired in series to the monitoring contact feedback input of the Primary Safety Device, as shown in [Figure 1](#) on page 5. In operation, if one of the switching contacts of any MSC fails in the shorted condition, the associated monitor contact will remain open. As a result, it will not be possible to reset the Primary Safety Device.

**NOTE:** To allow the Primary Safety Device to properly monitor the MSC feedback monitoring circuit, the installation’s total series resistance (wire and contact) must not exceed manufacturer’s specifications (typically 30 Ohm resistance). If this value is exceeded, the Primary Safety Device may not allow a reset of the System.

Many types of mechanisms are used to arrest dangerous machine motion. Examples include mechanical braking systems, clutch mechanisms, and combinations of brakes and clutches. Additionally, control of the arresting scheme may be hydraulic or pneumatic. As a result, an MSC may be one of several control types, including a wide variety of contactors and electromechanical valves. If your machine documentation leaves any doubt about the proper connection points for the Safety Extension Module output contacts, do not make any connections. Contact the machine builder for clarification regarding connection to the MSCs.

**NOTICE** regarding MSCs. To achieve control reliability, two redundant Master Stop Control Elements (MSCs) are required to control each machine hazard. Each MSC must be capable of immediately stopping the dangerous machine motion, irrespective of the state of the other. Some machines offer only one primary control element. For such machines, it is necessary to duplicate the circuit of the single MSC to add a second MSC. MSCs must offer at least one forced-guided auxiliary contact which is wired to the monitoring contact feedback input of the Primary Safety Device (see [Figure 1](#) on page 5).



**WARNING:** Zero-speed **detection** circuitry is required for reverse current braking **applications**. Applications that use reverse current motor braking require zero-speed detection circuitry to prevent the motor from starting in the reverse direction. This additional circuitry is necessary in situations where motor reversal may cause a machine hazard and/or machine damage. Model EM-FD-7Gx extension modules DO NOT provide zero-speed detection circuitry.



**WARNING:**

**MSC Monitoring**— All Master Stop Control elements (MSCs), such as control relays, must be of forced-guided, **captive** contact design to allow the MSC Monitoring circuit to detect unsafe failures within the master stop control elements. This monitoring extends the safe switching point of the Primary Safety Device and the EM-FD-7G Series Safety Extension Module to the MSC elements. For this monitoring to be effective, a minimum of two redundant MSCs are required to control each hazard. This is to detect the unsafe failure of one MSC (e.g., a welded contact), while stopping the hazard and preventing a successive machine cycle with the second MSC.

If the MSCs are the last electrically controlled device **generating** the hazard (i.e., not relays or contactors) and they do not have forced-guided, **captive** contacts to monitor (such as a solenoid), then the customer must ensure that failure or fault of any single component of the MSCs will prevent a successive machine cycle and will not result in a hazardous **situation**.

MSC monitoring is also called external device monitoring (EDM), MPCE feedback, and relay backchecking.

## Initial Checkout Procedure

The Safety Extension Module can be used safely only when its operation is controlled via an appropriate Primary Safety Device, connected to the Extension Module according to the wiring diagram.



**CAUTION:** Disconnect Power Prior to Checkout

Before performing the **initial** checkout procedure, make certain all power is disconnected from the machine to be controlled.

Dangerous voltages may be present along the Safety Module wiring barriers whenever power to the machine control elements is On. Exercise extreme **caution** whenever machine control power is or may be present. Always disconnect power to the machine control elements before opening the enclosure housing of the Safety Module.

1. Remove the power controlling (and switched by) the machine control elements.
2. Verify that the Primary Safety Device which will be controlling the Safety Extension Module is operating correctly, according to its product documentation and manufacturer's recommendations.
3. Confirm proper connection of the Safety Extension Module to the controlling Primary Safety Device according to the wiring diagram.
4. Verify that all four Safety Extension Module output contacts follow exactly the operation of the safety output contacts of the controlling Primary Safety Device, within the specified delay time, when the Primary Safety Device is operated according to its product documentation and manufacturer's recommendations.

## Periodic Checkout Procedure

---

The checkout procedures should be performed according to the intervals specified by the product documentation of the Primary Safety Device controlling this Safety Extension Module.

## Repairs

---

Contact Banner Engineering for troubleshooting of this device. Do not **attempt** any repairs to this Banner device; it contains no **field-replaceable** parts or components. If the device, device part, or device component is determined to be defective by a Banner Applications Engineer, they will advise you of Banner's **RMA (Return Merchandise Authorization)** procedure.



**Important:** If instructed to return the device, pack it with care. Damage that occurs in return shipping is not covered by warranty.

## Banner Engineering Corp. Limited Warranty

---

Banner Engineering Corp. warrants its products to be free from defects in material and workmanship for one year following the date of shipment. Banner Engineering Corp. will repair or replace, free of charge, any product of its manufacture which, at the time it is returned to the factory, is found to have been defective during the warranty period. This warranty does not cover damage or liability for misuse, abuse, or the improper application or installation of the Banner product.

THIS LIMITED WARRANTY IS EXCLUSIVE AND IN LIEU OF ALL OTHER WARRANTIES WHETHER EXPRESS OR IMPLIED (INCLUDING, WITHOUT LIMITATION, ANY WARRANTY OF MERCHANTABILITY OR FITNESS FOR A PARTICULAR PURPOSE), AND WHETHER ARISING UNDER COURSE OF PERFORMANCE, COURSE OF DEALING OR TRADE USAGE.

This Warranty is exclusive and limited to repair or, at the discretion of Banner Engineering Corp., replacement. IN NO EVENT SHALL BANNER ENGINEERING CORP. BE LIABLE TO BUYER OR ANY OTHER PERSON OR ENTITY FOR ANY EXTRA COSTS, EXPENSES, LOSSES, LOSS OF PROFITS, OR ANY INCIDENTAL, CONSEQUENTIAL OR SPECIAL DAMAGES RESULTING FROM ANY PRODUCT DEFECT OR FROM THE USE OR INABILITY TO USE THE PRODUCT, WHETHER ARISING IN CONTRACT OR WARRANTY, STATUTE, TORT, STRICT LIABILITY, NEGLIGENCE, OR OTHERWISE.

Banner Engineering Corp. reserves the right to change, modify or improve the design of the product without assuming any obligations or liabilities relating to any product previously manufactured by Banner Engineering Corp. Any misuse, abuse, or improper application or installation of this product or use of the product for personal protection applications when the product is identified as not intended for such purposes will void the product warranty. Any modifications to this product without prior express approval by Banner Engineering Corp will void the product warranties. All specifications published in this document are subject to change; Banner reserves the right to modify product specifications or update documentation at any time. Specifications and product information in English supersede that which is provided in any other language. For the most recent version of any documentation, refer to:

[www.bannerengineering.com](http://www.bannerengineering.com).